

# SKETCH/AREA TABLE ADDENDUM

## SUBJECT INFO

File No.: 331519 Parcel No.: 063W33DD03100  
 Property Address: 5337 BURBANK ST N  
 City: KEIZER County: Marion State: OR ZipCode: 97303  
 Owner:  
 Client: Client Address:  
 Appraiser Name: Inspection Date:

## SKETCH

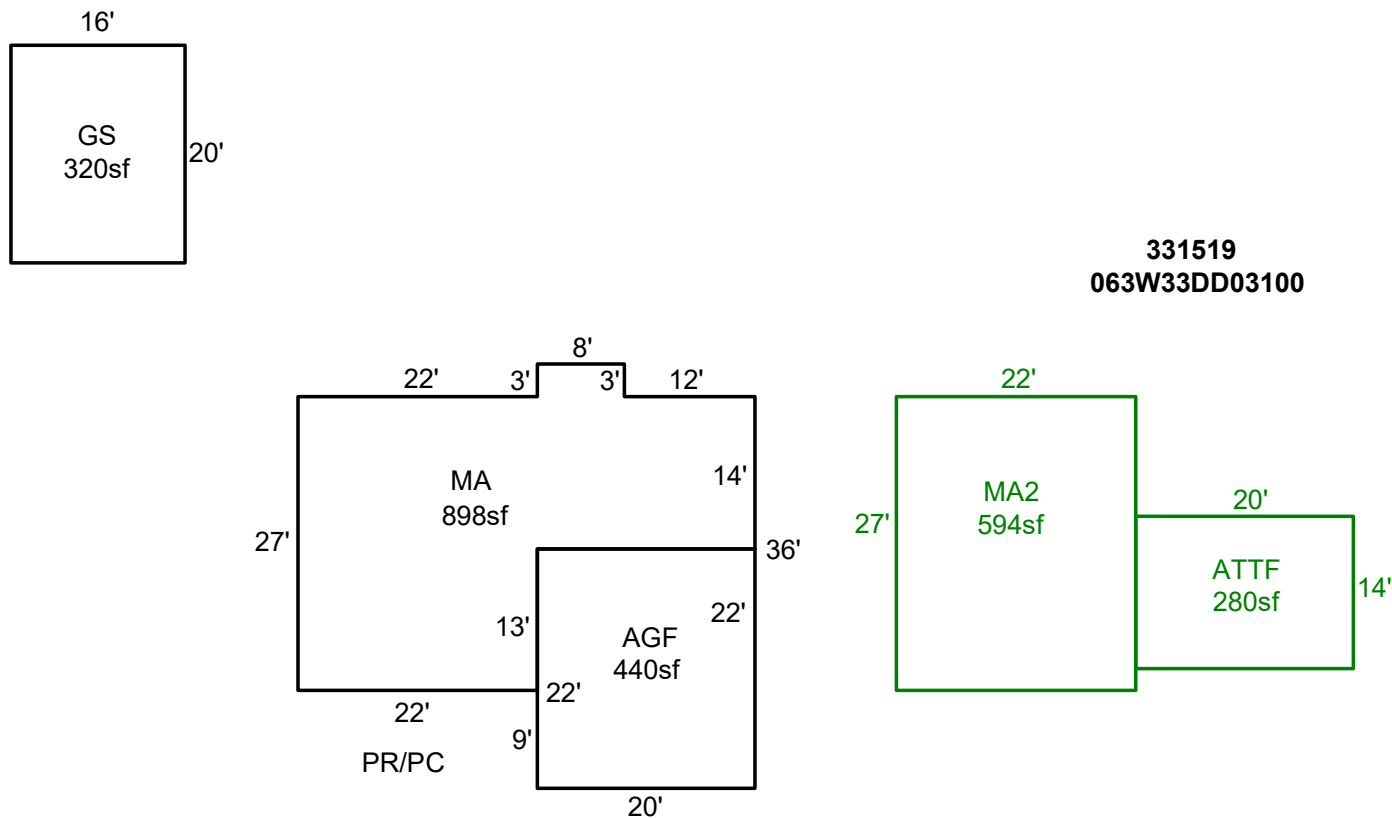

**331519**  
**063W33DD03100**

Sketch by ApexSketch

### AREA CALCULATIONS SUMMARY

Code	Description	Factor	Net Size	Perimeter	Net Totals
GBA	GS	1.0	320.0	72.0	320.0
GLA1	MA	1.0	898.0	144.0	898.0
GLA2	MA2	1.0	594.0	98.0	
	ATTF	1.0	280.0	68.0	874.0
GAR	AGF	1.0	440.0	84.0	440.0

### COMMENT TABLE 1

DRAWN BY SH 5-27-08  
Updated by AE 3.7.25

### COMMENT TABLE 2

### COMMENT TABLE 3

Net LIVABLE	cnt	3	(rounded)	1,772
Net BUILDING	cnt	1	(rounded)	320