

# SKETCH/AREA TABLE ADDENDUM

## SUBJECT INFO

File No.: 537153 Parcel No.: 103W11DA02700  
 Property Address: 506 S MAIN ST  
 City: JEFFERSON County: State: OR ZipCode: 97352  
 Owner:  
 Client: Client Address:  
 Appraiser Name: Inspection Date:

## SKETCH

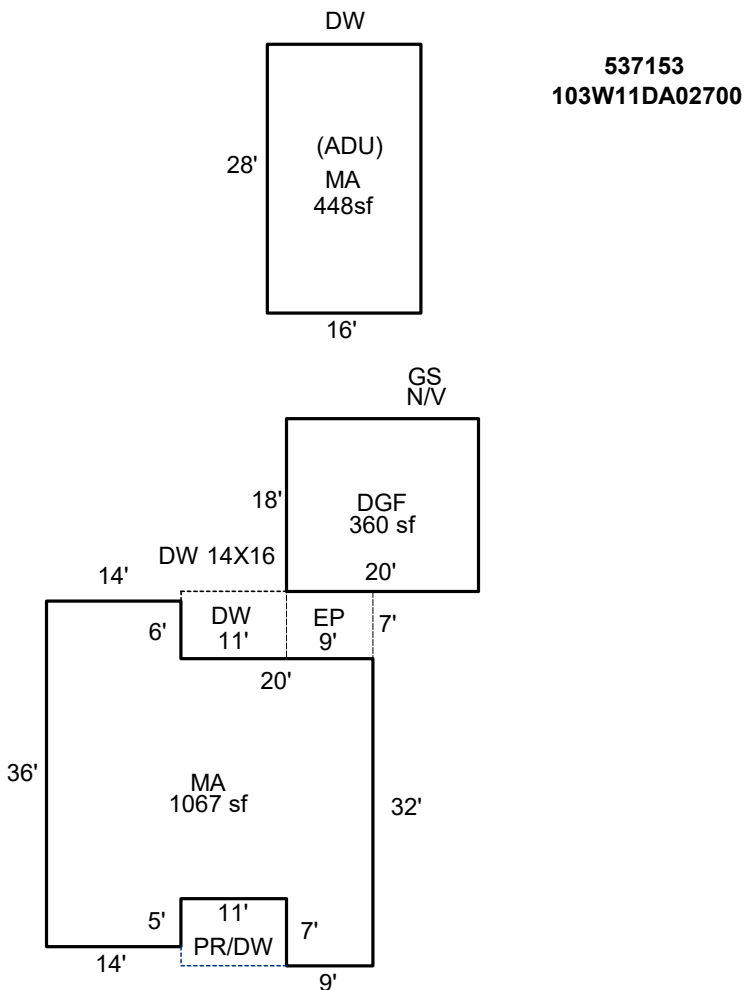

Sketch by ApexSketch

### AREA CALCULATIONS SUMMARY

Code	Description	Factor	Net Size	Perimeter	Net Totals
GLA	MA	1.0	448.0	88.0	448.0
GLA1	MA	1.0	1067.0	154.0	1067.0
GAR	AGF	1.0	360.0	76.0	360.0
P/P	EP	1.0	63.0	32.0	63.0

### COMMENT TABLE 1

DRAWN BY PST 2/09/09  
 UPDATED BY RESTILL 6/24/16  
 UPDATED BY LK 3.10.25

### COMMENT TABLE 2

5-16-16 42 CYCLE NV  
 3.6.25 CYCLE GM

### COMMENT TABLE 3

Net LIVABLE                      cnt                      1      (rounded)                      1,515