

Acct ID: 536218 MTL: 093W050000900 Date: 1/16/25 Appr: GRH Prop Class: 551 RMV Prop Class: 501
 Situs: 9904 SIDNEY RD S SALEM OR 97306 MaSaNh: 06 06 000 Unit: 62957 Year: 2024

Last Date Appraised: 06/11/2010 Appraiser: WENDY WILLIAMS Retag: Y N Tag info: 2025 - Tags/Permit (Miscellaneous)
 Owner: ALMA JONES PAYNE TR Roll Type: R
 Cycle: Tag Sales Verification Other: _____ Inspection level: 1 2 3 4 LCB TTO INSP AV: 245147
 RMV Land: 690140 RMV Imp: 98910 RMV Total: 789050 MAV: 71990 MSAV: 173157 SAV: 520507

Comment: cycle 9.10.24
Not comfortable w/ 12 should be 609959

Notations No changes observed, update inv RE-APPRAISE DUE TO WAREHOUSE TRANSFER FROM COMM TO RURAL . WW

RP/MS	Code	Description
RP	ZONED	FARM EFU ZONED

Farm: Grass seed

Count	Code	Description	RMV	Code Area	Exception
1	SAA	SA OSD - AVERAGE	45000	14530	0

Land Chris 3/26/25

Site: 3 Code Area: 14530 Size: 1.00 Acres Use Code: 005 Zone: REST SAV Use: 011 Exception: 0
 Class: 4BISS Value Source: Farm Homesite Description: FOUR BENCH IRR SPECIAL SOUTH RMV: 4500 Exception: Y N
 Adjustment(s): GSOIL, WASTE, IRR Fire Patrol: Description:
 Comments: Liability year - 2009
 24-25: Update land classes
 09-10: GW39 changed land type per Excel analysis// 81400130: 01-02: UPDATED LAND MARKET VALUE BASED ON PART TOTAL INFORMATION

Site: 4 Code Area: 14530 Size: 67.74 Acres Use Code: 005 Zone: REST SAV Use: 011 Exception: 0
 Class: 2BISS Value Source: Farm Use - EFU Description: TWO BENCH IRR SOUTH SPECIAL RMV: 350550 Exception: Y N
 Adjustment(s): GSOIL, WASTE, IRR Fire Patrol: Description:
 Comments: Liability year - 1980

Site: 5 Code Area: 14530 Size: 60.88 Acres Use Code: 005 Zone: REST SAV Use: 011 Exception: 0
 Class: 4BISS Value Source: Farm Use - EFU Description: FOUR BENCH IRR SPECIAL SOUTH RMV: 287660 Exception: Y N
 Adjustment(s): GSOIL, WASTE, IRR Fire Patrol: Description:
 Comments: Liability year - 1980 / 81400130

Site: 6 Code Area: 14530 Size: 12.00 Acres Use Code: 005 Zone: REST SAV Use: 011 Exception: 0
 Class: WST Value Source: Water Description: Rural WASTELAND RMV: 1620 Exception: Y N
 Adjustment(s): GSOIL, WASTE, IRR Fire Patrol: Description:
 Comments: Liability year - 1980
 Pond

Site: 8 Code Area: 14530 Size: 6.00 Acres Use Code: 005 Zone: REST SAV Use: 011 Exception: 0
 Class: WST Value Source: WASTE RURAL Description: Rural WASTELAND RMV: 810 Exception: Y N
 Adjustment(s): GSOIL, WASTE, IRR Fire Patrol: Description:
 Comments: Liability year - 1980 / 81400130: 2010-11: MOVED 15.3 ACRES FROM WOODLOT TO WASTELAND //08-09: 8BENCH PROJECT - CHG OF 8HILL TO 6HILL//

Improvements - Residence / Manufactured Structures

Bldg: 1 Code Area: 14530 Stat Class: 121 + Year Blt: 1974 Eff Year Blt: 1974 Sq.Ft: 578 % Complete: 100
 Desc: One Story Only Dimensions: RMV: 91260
 Func Obsc: 100 Econ %: 100 Other %: 100 Exception: 0 Adjust: Adjust RMV: 0

1988 updated roof

Floors

Type	Class	Display Group	Floor Size	Beds	Baths	Yr Blt	Eff Yr Blt	Inventory	Exception
First Floor	2 +	Finished	578	1	FB-1	1974	<u>1974</u>	BATH - 1, KIT, ROOF, HVAC, FP - 1	Y N

Accessories

Description	Class	Size SqFt	Eff Yr Blt	RMV	Quantity	Exception
DECK	2	601	1974	9135	1	Y N
ROOF EXTENSION OR PATIO COVER	2	238	1974	5246	1	Y N

YI 3 grouped together:

Improvements - Accessory Buildings

Bldg: 2 Code Area: 14530 Stat Class: 351 Year Blt: 1962 Eff Year Blt: 1962 Sq.Ft: 532 % Complete: 100
 Desc: General Purpose Building (GB) Dimensions: RMV: 2120
 Func Obsc: 100 Econ %: 100 Other %: 100 Exception: 0 Adjust: Adjust RMV: 0

Floors

I/O

Type	Class	Display Group	Floor Size	Beds	Baths	Yr Blt	Eff Yr Blt	Inventory	Exception: Y N
General Purpose Bldg	4	Finished	532	0	FB-1	1962	1962	BATH - 1, FAIR	Y N

Arts

Accessories

Description	Class	Size SqFt	Eff Yr Blt	RMV	Quantity
No accessory data available					

Bldg: 3	Code Area: 14530	Stat Class: 353	Year Blt: 1962	Eff Year Blt: 1962	Sq.Ft: 1872	% Complete: 100
Desc: Machine Shed (MS)			Dimensions: 72x26		RMV: 5530	
Func Obsc: 100	Econ %: 100	Other %: 100	Exception: 0	Adjust:	Adjust RMV: 0	

N/C

Floors

Type	Class	Display Group	Floor Size	Beds	Baths	Yr Blt	Eff Yr Blt	Inventory	Exception: Y N
Machine Shed	5	Finished	1872	0	0	1962	1962	FAIR	Y N

Accessories

Description	Class	Size SqFt	Eff Yr Blt	RMV	Quantity
No accessory data available					

SKETCH/AREA TABLE ADDENDUM

SUBJECT INFO

File No.: 536218 Parcel No.: 093W05 00900
 Property Address: 9904 Sidney Rd S
 City: Salem County: State: OR ZipCode: 97306
 Owner:
 Client: Client Address:
 Appraiser Name: Inspection Date:

SKETCH

536218
093W05 00900

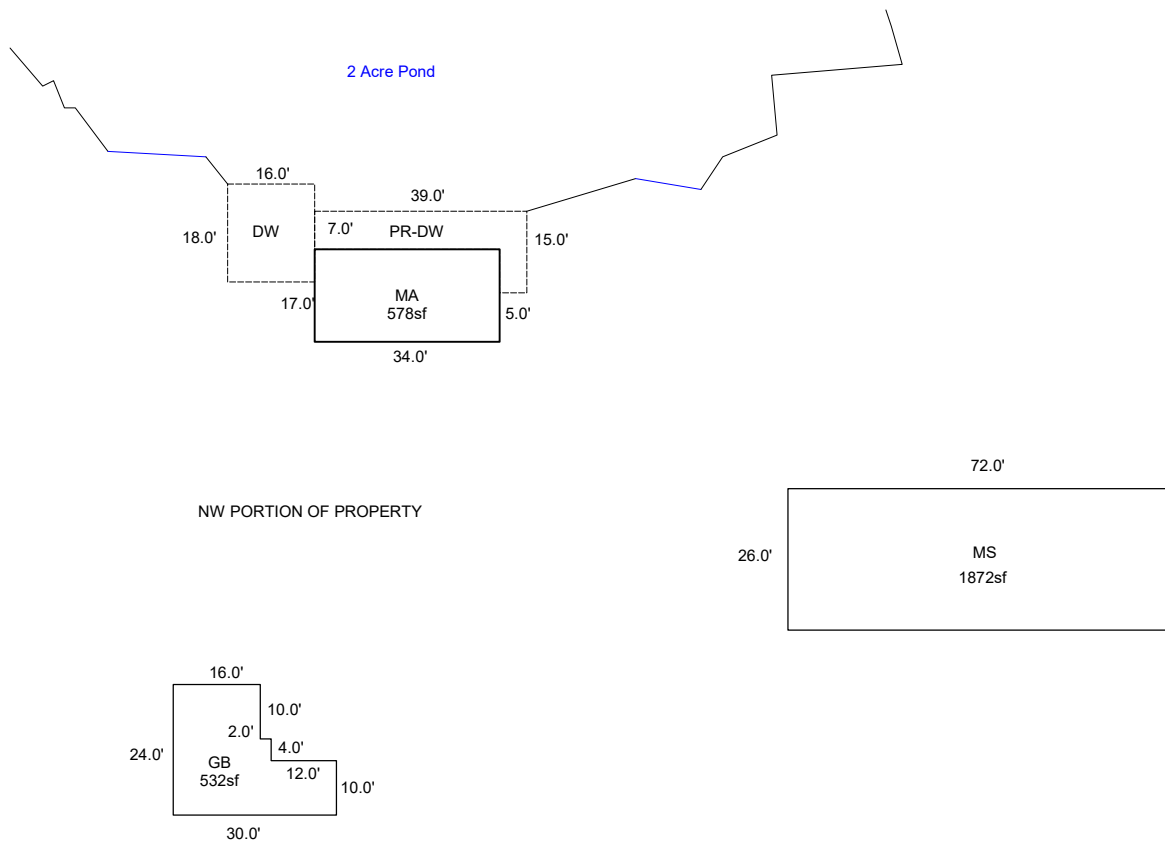

Sketch by ApexSketch

AREA CALCULATIONS SUMMARY						COMMENT TABLE 1	
Code	Description	Factor	Net Size	Perimeter	Net Totals		
GLA1	MA	1.0	578.0	102.0	578.0	Apex by JA 11/17/09 UPDATED BY CLOBERG 02/19/25	
OTH	MS	1.0	1872.0	196.0			
	GB	1.0	532.0	108.0	2404.0		
P/P	PR-DF	1.0	313.0	108.0			
	DF	1.0	288.0	68.0	601.0		
	Net LIVABLE	cnt	0 (rounded)		578	COMMENT TABLE 2	COMMENT TABLE 3
						GRH 01/16/25	TAGS L3

2 Acre Pond

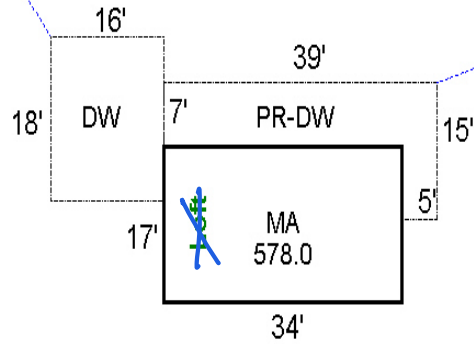

R36218
093W05 00900

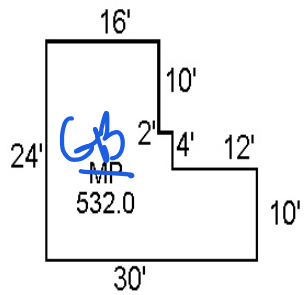
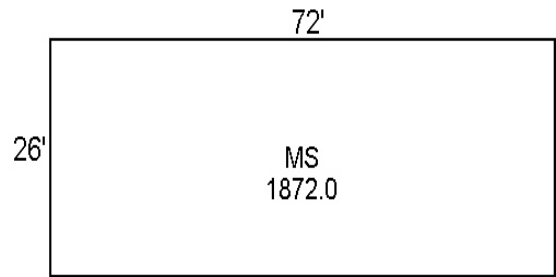

delete Firm Apex

I/O Account R36220

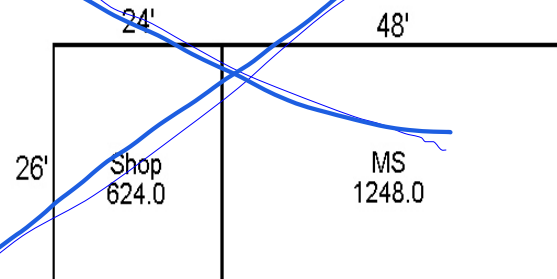

*GRH 11/16/25
TAGS L3*