

Acct ID: 535175 MTL: 092W07A000600 Date: 1/14/25 Appr: MDL Prop Class: 551 RMV Prop Class: 551
 Situs: 10275 PARRISH GAP RD SE TURNER OR 97392 MaSaNh: 07 06 000 Unit: 71385 Year: ~~2024~~ 2025
 Last Date Appraised: 01/02/2024 Appraiser: MATT LORD Retag: Y N Tag info: 2025 - NEW CONSTRUCTION (Outbuilding)
 Owner: MANZO-GARCIA, EULALIO Roll Type: R
 Cycle: Tag Sales Verification Other: _____ Inspection level: 1 2 3 4 LCB TTO INSP AV: 155784
 RMV Land: 333280 RMV Imp: 241890 RMV Total: 575170 MAV: 109870 MSAV: 30014 SAV: 46197
 Comment: 24-25: L3 MDL 1.2.24 TAG complete for 24-25 **3.3 acres used as homesite; the rest looks like hay**

Chris 3/13/25 Send inquiry letter with aerial asking about use

Notations 25-26 addition complete tab should of been pulled / no new MS onsite ✓ 1/1/26

RP/MS	Code	Description
RP	ZONED	FARM EFU ZONED

OSDs

Count	Code	Description	RMV	Code Area	Exception
1	SAA	SA OSD - AVERAGE	45000	05590	0

Land ✓

Site: 2	Code Area: 05590	Size: 1.00 Acres	Use Code: 005	Zone: REST	SAV Use: 011	Exception: 0
Class: 4HD	Value Source: Farm Homesite	Description: FOUR HILL DRY	RMV: 24640	Exception: Y	N	
Adjustment(s): GSOIL	Fire Patrol:	Description:				
Comments: Liability year - 2009 / 00550190						
Site: 3	Code Area: 05590	Size: 2.00 Acres	Use Code: 005	Zone: REST	SAV Use: 011	Exception: 0
Class: 2BDS S	Value Source: Farm Use - EFU	Description: TWO BENCH DRY SOUTH SPECIAL	RMV: 54210	Exception: Y	N	
Adjustment(s): GSOIL	Fire Patrol:	Description:				
Comments: Liability year - 1981 / 00500190 06-19-02: CORR LAND SCHED PER DK #87.						
Site: 4	Code Area: 05590	Size: 8.50 Acres	Use Code: 005	Zone: REST	SAV Use: 011	Exception: 0
Class: 4HD	Value Source: Farm Use - EFU	Description: FOUR HILL DRY	RMV: 209430	Exception: Y	N	
Adjustment(s): GSOIL	Fire Patrol:	Description:				
Comments: Liability year - 1981 / 00500190: 01-02; CHANGED SOIL CLASS FROM 3 HILL DRY TO 4 HILL DRY						

Improvements - Residence / Manufactured Structures

Bldg: 1	Code Area: 05590	Stat Class: 132	Year Blt: 1924	Eff Year Blt: 1935	Sq.Ft: 2100	% Complete: 100
Desc: Multi Story above grade	Dimensions:	RMV: 184930				
Func Obsc: 100	Econ %: 100	Other %: 100	Exception: 0	Adjust:	Adjust RMV: 0	

Floors

Type	Class	Display Group	Floor Size	Beds	Baths	Yr Blt	Eff Yr Blt	Inventory	Exception
First Floor	3	Finished	1300	1	FB-1	1924	1935	BATH - 1, KIT-, ROOF, HVAC+, FP - 1	Y N
Attic	3	Finished	800	2	0	1924	1935	HVAC	Y N
Carport Attached	2	Unfinished	240	0	0	1924	1900	ROOF	Y N

Accessories

Description	Class	Size SqFt	Eff Yr Blt	RMV	Quantity	Exception
ENCLOSED PORCH	2	224	1935	3416	1	Y N
YARD IMPROVEMENTS AVERAGE	3	1	1935	10211	1	Y N

Improvements - Accessory Buildings

Bldg: 3	Code Area: 05590	Stat Class: 353	Year Blt: 1966	Eff Year Blt: 1966	Sq.Ft: 600	% Complete: 100
Desc: Machine Shed (MS)	Dimensions: 30x20	RMV: 1360				
Func Obsc: 100	Econ %: 100	Other %: 100	Exception: 0	Adjust:	Adjust RMV: 0	

Floors

Type	Class	Display Group	Floor Size	Beds	Baths	Yr Blt	Eff Yr Blt	Inventory	Exception
Machine Shed	4	Finished	600	0	0	1966	1966	FAIR	Y N

Accessories

Description	Class	Size SqFt	Eff Yr Blt	RMV	Quantity
No accessory data available					

Floors

Bldg: 4	Code Area: 05590	Stat Class: 351	Year Blt: 1966	Eff Year Blt: 1966	Sq.Ft: 1680	% Complete: 100
Desc: General Purpose Building (GB)	Dimensions: 70x24	RMV: 5880				
Func Obsc: 100	Econ %: 100	Other %: 100	Exception: 0	Adjust:	Adjust RMV: 0	

Type	Class	Display Group	Floor Size	Beds	Baths	Yr Blt	Eff Yr Blt	Inventory	
General Purpose Bldg	4	Finished	1680	0	0	1966	1966	AVG	Exception: Y N

Accessories

Description	Class	Size SqFt	Eff Yr Blt	RMV	Quantity
No accessory data available					

Bldg: 5 Code Area: 05590 Stat Class: 351 Year Blt: 1964 Eff Year Blt: 1964 Sq.Ft: 660 % Complete: 100
 Desc: General Purpose Building (GB) Dimensions: 30x22 RMV: 2150
 Func Obsc: 100 Econ %: 100 Other %: 100 Exception: 0 Adjust: Adjust RMV: 0

Floors

Type	Class	Display Group	Floor Size	Beds	Baths	Yr Blt	Eff Yr Blt	Inventory	
General Purpose Bldg	4	Finished	660	0	0	1964	1964	FAIR	Exception: Y N

Accessories

Description	Class	Size SqFt	Eff Yr Blt	RMV	Quantity
No accessory data available					

Bldg: 6 Code Area: 05590 Stat Class: 354 Year Blt: 1966 Eff Year Blt: 1966 Sq.Ft: 1944 % Complete: 100
 Desc: Lean-to Light (LTL) Dimensions: 42x16 RMV: 1570
 Func Obsc: 100 Econ %: 100 Other %: 100 Exception: 0 Adjust: Adjust RMV: 0

Floors

Type	Class	Display Group	Floor Size	Beds	Baths	Yr Blt	Eff Yr Blt	Inventory	
Lean-to Light Duty	4	Finished	1944	0	0	1966	1966		Exception: Y N

Accessories

Description	Class	Size SqFt	Eff Yr Blt	RMV	Quantity
No accessory data available					

Bldg: 7 Code Area: 05590 Stat Class: 301 Year Blt: Eff Year Blt: Sq.Ft: 64 % Complete: 100
 Desc: Accessory Improvements & Misc. Dimensions: 8x8 RMV: 0
 Func Obsc: 100 Econ %: 100 Other %: 100 Exception: 0 Adjust: Adjust RMV: 0

Floors

Type	Class	Display Group	Floor Size	Beds	Baths	Yr Blt	Eff Yr Blt	Inventory	
Pump House	0	Finished	64	0	0	0	0		Exception: Y N

Accessories

Description	Class	Size SqFt	Eff Yr Blt	RMV	Quantity
No accessory data available					

Bldg: 9 Code Area: 05590 Stat Class: 353 Year Blt: 1966 Eff Year Blt: 1998 Sq.Ft: 3168 % Complete: 100
 Desc: Machine Shed (MS) Dimensions: 60x24, 24x72 RMV: 26090
 Func Obsc: 100 Econ %: 100 Other %: 100 Exception: 6360 Adjust: Adjust RMV: 0

Floors

Type	Class	Display Group	Floor Size	Beds	Baths	Yr Blt	Eff Yr Blt	Inventory	
Machine Shed	5	Finished	1440	0	0	1966	1998	AVG	Exception: Y N
Machine Shed	5	Finished	1728	0	0	1966	1998		Exception: Y N

Accessories

Description	Class	Size SqFt	Eff Yr Blt	RMV	Quantity
No accessory data available					

Bldg: 10 Code Area: 05590 Stat Class: 354 Year Blt: 1966 Eff Year Blt: 1966 Sq.Ft: 360 % Complete: 100
 Desc: Lean-to Light (LTL) Dimensions: 30x12 RMV: 290
 Func Obsc: 100 Econ %: 100 Other %: 100 Exception: 0 Adjust: Adjust RMV: 0

Floors

Type	Class	Display Group	Floor Size	Beds	Baths	Yr Blt	Eff Yr Blt	Inventory	
Lean-to Light Duty	5	Finished	360	0	0	1966	1966		Exception: Y N

Accessories

Description	Class	Size SqFt	Eff Yr Blt	RMV	Quantity
No accessory data available					

Bldg: 11 Code Area: 05590 Stat Class: 820 Year Blt: 2005 Eff Year Blt: Sq.Ft: 288 % Complete: 100
 Desc: OTHER SCHOOLS Dimensions: RMV: 19620
 Func Obsc: 100 Econ %: 100 Other %: 100 Exception: 9540 Adjust: Adjust RMV: 0

Floors

Type	Class	Display Group	Floor Size	Beds	Baths	Yr Blt	Eff Yr Blt	Inventory
No floor data available								
Accessories								
Description	Class	Size SqFt	Eff Yr Blt	RMV	Quantity			
No accessory data available								

SKETCH/AREA TABLE ADDENDUM

SUBJECT INFO

File No.: 535175 Parcel No.: 092W07A 00600
 Property Address: 10275 PARRISH GAP RD SE
 City: TURNER County: MARION State: OR ZipCode: 97392
 Owner:
 Client: Client Address:
 Appraiser Name: Inspection Date:

SKETCH

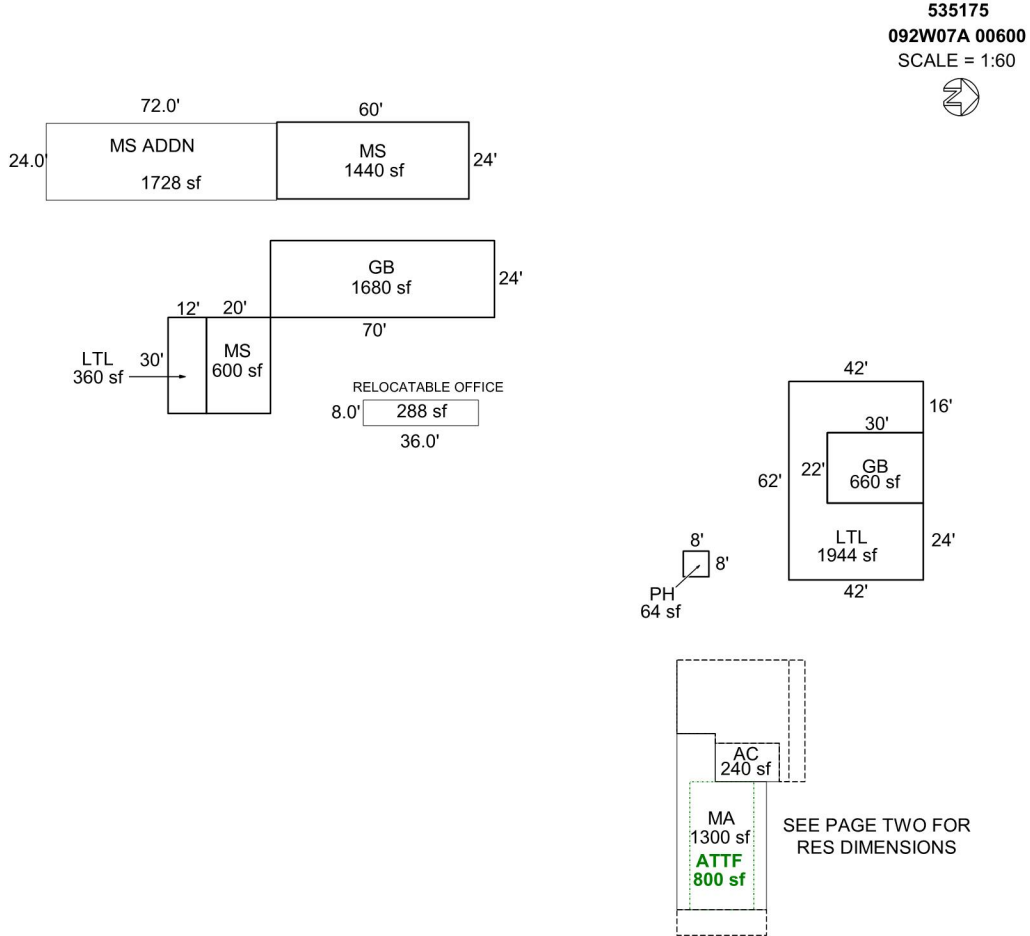

Sketch by ApexSketch

AREA CALCULATIONS SUMMARY

Code	Description	Factor	Net Size	Perimeter	Net Totals
GBA1	MS	1.0	600.0	100.0	
	GB	1.0	1680.0	188.0	
	MS	1.0	1440.0	168.0	
	GB	1.0	660.0	104.0	
	LTL	1.0	1944.0	268.0	
	LTL	1.0	360.0	84.0	
	PH	1.0	64.0	32.0	6748.0
GBA4	MS ADDN	1.0	1728.0	192.0	1728.0
GBA6	RELOCATABLE OF	1.0	288.0	88.0	288.0
GLA1	MA	1.0	1300.0	166.0	1300.0
ATTF	ATTF	1.0	800.0	120.0	800.0
GAR	AC	1.0	240.0	64.0	240.0
P/P	EP	1.0	224.0	72.0	
	PF	1.0	910.0	146.0	
	PC	1.0	1100.0	156.0	2234.0
	Net LIVABLE	cnt	1 (rounded)		1,300
	Net BUILDING	cnt	9 (rounded)		8,764

COMMENT TABLE 1

APEXED BY NRC 10/19/2009
 UPDATED BY CJURAN 03/12/2024
 UPDATED BY WW 4.22.24

COMMENT TABLE 2

MDL 01/02/2023

COMMENT TABLE 3

TAGS L3

SKETCH/AREA TABLE ADDENDUM

SUBJECT INFO

File No.: 535175 Parcel No.: 092W07A 00600
 Property Address: 10275 PARRISH GAP RD SE
 City: TURNER County: MARION State: OR ZipCode: 97392
 Owner:
 Client: Client Address:
 Appraiser Name: Inspection Date:

SKETCH

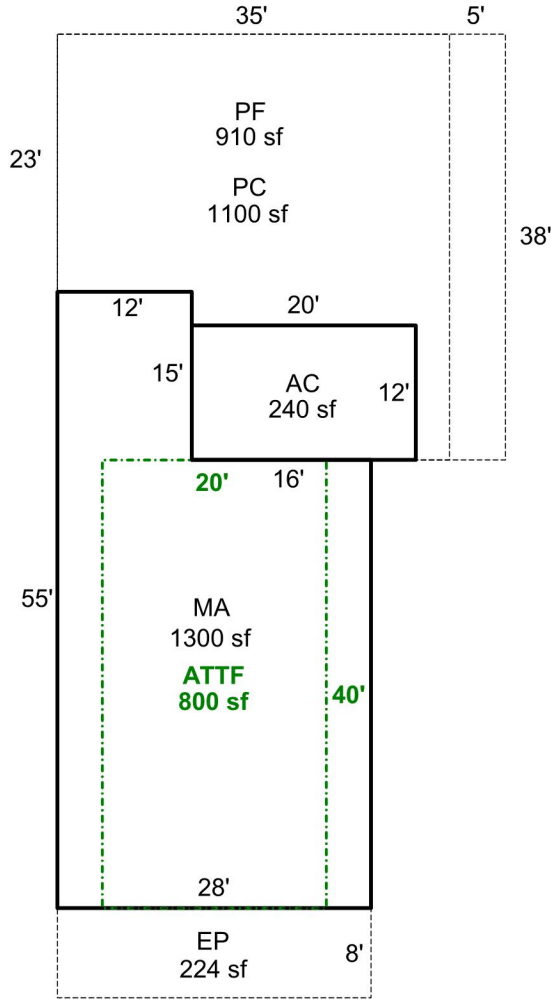

535175
092W07A 00600
 SCALE = 1:20



Sketch by ApexSketch

AREA CALCULATIONS SUMMARY

Code	Description	Factor	Net Size	Perimeter	Net Totals
GLA1	MA	1.0	1300.0	166.0	1300.0
ATTF	ATTF	1.0	800.0	120.0	800.0
GAR	AC	1.0	240.0	64.0	240.0
P/P	EP	1.0	224.0	72.0	
	PF	1.0	910.0	146.0	
	PC	1.0	1100.0	156.0	2234.0

COMMENT TABLE 1

APEXED BY NRC 10/19/2009
 UPDATED BY CJURAN 03/12/2024
 UPDATED BY WW 4.22.24

COMMENT TABLE 2

MDL 01/02/2023

COMMENT TABLE 3

TAGS L3

Net LIVABLE cnt 1 (rounded) 1,300



10275

R35175

01-6-2013



R35175Hay

01-6-2013



R35175cows

01-6-2013