

Summary

ww 5.12.25

Lead Appr: _____ Clerk: _____ Lead Clerk: _____ Appr: MLH 5/13/25

Print Date:

4/16/2025

Acct ID: 528204 MTL: 081W120000100 Date: 4/30/25 Appr: MLH Prop Class: 551 RMV Prop Class: 551 501
Situs: 14765 WALDO HILLS DR SE SUBLIMITY OR 97385 MaSaNh: 01 06 000 Unit: 41352 Year: 2025

Last Date Appraised: 04/21/2017 Appraiser: CLINT LUKE Retag: Y N Tag info:

Owner: SEVENTEEN OAKS LLC Roll Type: R

Cycle Tag Sales Verification Other: Clean up Inspection level: 1 2 3 4 LCB TTO INSP AV: 317361

RMV Land: 1002000 RMV Imp: 199860 RMV Total: 1201860 MAV: 147250 MSAV: 170111 SAV: 286012

Comment:

update Inventory

Input MLH 5/9/25

Notations

RP/MS	Code	Description
RP	ZONED	FARM EFU ZONED

OSDs

Count	Code	Description	RMV	Code Area	Exception
2	SAA	SA OSD - AVERAGE	50000	04580	0

Land

Site: 2 Code Area: 04580 Size: 1.00 Acres Use Code: 005 Zone: REST SAV Use: 011 Exception: 0
 Class: Value Source: Farm Homesite Description: RMV: 5000 Exception: Y N
 Adjustment(s): GSOIL, WASTE Fire Patrol: SA004 Description: FIRE PATROL
 Comments: Liability year - 2009 / 04200188

Site: 3 Code Area: 04580 Size: 72.00 Acres Use Code: 005 Zone: REST SAV Use: 011 Exception: 0
 Class: 2HD Value Source: Farm Use - EFU Description: TWO HILL DRY RMV: 396000 Exception: Y N
 Adjustment(s): GSOIL, WASTE Fire Patrol: SA004 Description: FIRE PATROL
 Comments: Liability year - 1974 / 04200188

Site: 4 Code Area: 04580 Size: 107.40 Acres Use Code: 005 Zone: REST SAV Use: 011 Exception: 0
 Class: 4HD Value Source: Farm Use - EFU Description: FOUR HILL DRY RMV: 537000 Exception: Y N
 Adjustment(s): GSOIL, WASTE Fire Patrol: SA004 Description: FIRE PATROL
 Comments: Liability year - 1974 / 4200188: 01-02; CHANGED SOIL CLASS FROM 3 HILL DRY TO 4 HILL DRY

Site: 5 Code Area: 04580 Size: 35.00 Acres Use Code: 005 Zone: REST SAV Use: 011 Exception: 0
 Class: WST Value Source: Farm Use - EFU Description: Rural WASTELAND RMV: 14000 Exception: Y N
 Adjustment(s): GSOIL, WASTE Fire Patrol: SA004 Description: FIRE PATROL
 Comments: Liability year - 1974 / 17-18: CYCLE WORK #94 NO CHG// 08-09: EIGHT BENCH PROJ - CHG FROM EIGHT BENCH TO WASTE// 4200008 // 05-06: RECALC SETUP;#10 5/26/04

Improvements - Residence / Manufactured Structures

Bldg: 1 Code Area: 04580 Stat Class: 142 Year Blt: 1909 Eff Year Blt: 1909 Sq.Ft: 1992 % Complete: 100
 Desc: Multi Story above grade Dimensions: RMV: 155690
 Func Obsc: 100 Econ %: 100 Other %: 100 Exception: 0 Adjust: Adjust RMV: 0

Floors

Type	Class	Display Group	Floor Size	Beds	Baths	Yr Blt	Eff Yr Blt	Inventory	Exception
First Floor	4	Finished	1316	0	FB-1	1909	1909	BATH - 1, KIT-, ROOF, HVAC, FP - 1	Y N
Second Floor	4	Finished	676	4	0	1909	1909		Y N

Accessories

Description	Class	Size SqFt	Eff Yr Blt	RMV	Quantity	Exception
ENCLOSED PORCH	4	100	1500	1020	1	Y N

Improvements - Accessory Buildings

Bldg: 2 Code Area: 04580 Stat Class: 341 Year Blt: 1909 Eff Year Blt: 1909 Sq.Ft: 280 % Complete: 100
 Desc: Multi Purpose Shed (MP) Dimensions: 20x14 RMV: 990
 Func Obsc: 100 Econ %: 100 Other %: 100 Exception: 0 Adjust: Adjust RMV: 0

Floors

Type	Class	Display Group	Floor Size	Beds	Baths	Yr Blt	Eff Yr Blt	Inventory	Exception
Multi-Purpose Bldg	4	Finished	280	0	0	1909	1909	Fair	Y N

Accessories

Description	Class	Size SqFt	Eff Yr Blt	RMV	Quantity
No accessory data available					

Bldg: 3 Code Area: 04580 Stat Class: 341 Year Blt: Eff Year Blt: Sq.Ft: 168 % Complete: 100
 Desc: Multi Purpose Shed (MP) Dimensions: 14x12 RMV: 3900

COMPANION ERROR

Func Obsc: 100 Econ %: 100 Other %: 100 Exception: 0 Adjust: Adjust RMV: 0

Floors

Type	Class	Display Group	Floor Size	Beds	Baths	Yr Blt	Eff Yr Blt	Inventory
Multi-Purpose Bldg	5	Finished	168	0	0	0	0	Exception: Y N

Accessories

Description	Class	Size SqFt	Eff Yr Blt	RMV	Quantity
No accessory data available					

Bldg: 4 Code Area: 04580 Stat Class: 341 Year Blt: Eff Year Blt: Sq.Ft: 84 % Complete: 100
 Desc: Multi Purpose Shed (MP) Dimensions: 14x6 RMV: 340
 Func Obsc: 100 Econ %: 100 Other %: 100 Exception: 0 Adjust: Adjust RMV: 0

>100 sf
φ

Floors

Type	Class	Display Group	Floor Size	Beds	Baths	Yr Blt	Eff Yr Blt	Inventory
Multi-Purpose Bldg	5	Finished	84	0	0	0	0	FAIR Exception: Y N

Accessories

Description	Class	Size SqFt	Eff Yr Blt	RMV	Quantity
No accessory data available					

Bldg: 5 Code Area: 04580 Stat Class: 353 Year Blt: 1973 Eff Year Blt: 1973 Sq.Ft: 800 % Complete: 100
 Desc: Machine Shed (MS) Dimensions: 40x20 RMV: 1600
 Func Obsc: 100 Econ %: 100 Other %: 100 Exception: 0 Adjust: Adjust RMV: 0

±/0

Floors

Type	Class	Display Group	Floor Size	Beds	Baths	Yr Blt	Eff Yr Blt	Inventory
Machine Shed	4	Finished	800	0	0	1973	1973	Fair ✓ Exception: Y N

Accessories

Description	Class	Size SqFt	Eff Yr Blt	RMV	Quantity
No accessory data available					

Bldg: 6 Code Area: 04580 Stat Class: 312 Year Blt: 1963 Eff Year Blt: 1963 Sq.Ft: 1680 % Complete: 100
 Desc: Loft Barn (LB) Dimensions: 56x30 RMV: 3940
 Func Obsc: 50 Econ %: 100 Other %: 100 Exception: 0 Adjust: Adjust RMV: 0

100

±/0

Floors

Type	Class	Display Group	Floor Size	Beds	Baths	Yr Blt	Eff Yr Blt	Inventory
Loft Barn	4	Finished	1680	0	0	1963	1963	Fair ✓ Exception: Y N

Accessories

Description	Class	Size SqFt	Eff Yr Blt	RMV	Quantity
No accessory data available					

Bldg: 7 Code Area: 04580 Stat Class: 355 Year Blt: 1973 Eff Year Blt: 1973 Sq.Ft: 1058 % Complete: 100
 Desc: Lean-to Heavy (LTH) Dimensions: RMV: 1430
 Func Obsc: 100 Econ %: 100 Other %: 100 Exception: 0 Adjust: Adjust RMV: 0

N/C

Floors

Type	Class	Display Group	Floor Size	Beds	Baths	Yr Blt	Eff Yr Blt	Inventory
Lean-to Heavy Duty	4	Finished	1058	0	0	1973	1973	Exception: Y N

Accessories

Description	Class	Size SqFt	Eff Yr Blt	RMV	Quantity
No accessory data available					

Bldg: 8 Code Area: 04580 Stat Class: 312 Year Blt: 1963 Eff Year Blt: 1963 Sq.Ft: 2206 % Complete: 100
 Desc: Loft Barn (LB) Dimensions: 50x44 RMV: 4940
 Func Obsc: 50 Econ %: 100 Other %: 100 Exception: 0 Adjust: Adjust RMV: 0

100

±/0

Floors

Type	Class	Display Group	Floor Size	Beds	Baths	Yr Blt	Eff Yr Blt	Inventory
Loft Barn	4	Finished	2206	0	0	1963	1963	Fair ✓ Exception: Y N

Accessories

Description	Class	Size SqFt	Eff Yr Blt	RMV	Quantity
No accessory data available					

Bldg: 9 Code Area: 04580 Stat Class: 341 Year Blt: 1974 Eff Year Blt: 1974 Sq.Ft: 432 % Complete: 100
 Desc: Multi Purpose Shed (MP) Dimensions: 24x18 RMV: 1360
 Func Obsc: 100 Econ %: 100 Other %: 100 Exception: 0 Adjust: Adjust RMV: 0

±/0

Floors

Type	Class	Display Group	Floor Size	Beds	Baths	Yr Blt	Eff Yr Blt	Inventory	Exception: Y N
Multi-Purpose Bldg	4	Finished	432	0	0	1974	1974	FAIR	

Accessories

Description	Class	Size SqFt	Eff Yr Blt	RMV	Quantity
No accessory data available					

Bldg: 10 Code Area: 04580 Stat Class: 351 Year Blt: 1963 Eff Year Blt: 1963 Sq.Ft: 2112 % Complete: 100
 Desc: General Purpose Building (GB) Dimensions: 48x44 RMV: 4990
 Func Obsc: 100 Econ %: 100 Other %: 100 Exception: 0 Adjust: Adjust RMV: 0

Floors

Type	Class	Display Group	Floor Size	Beds	Baths	Yr Blt	Eff Yr Blt	Inventory	Exception: Y N
General Purpose Bldg	4	Finished	2112	0	0	1963	1963	FAIR	

Accessories

Description	Class	Size SqFt	Eff Yr Blt	RMV	Quantity
No accessory data available					

Bldg: 11 Code Area: 04580 Stat Class: 301 Year Blt: Eff Year Blt: Sq.Ft: 80 % Complete: 100
 Desc: Accessory Improvements & Misc. Dimensions: 10x8 RMV: 0
 Func Obsc: 100 Econ %: 100 Other %: 100 Exception: 0 Adjust: Adjust RMV: 0

Floors

Type	Class	Display Group	Floor Size	Beds	Baths	Yr Blt	Eff Yr Blt	Inventory	Exception: Y N
Pump House	0	Finished	80	0	0	0	0	delete	

Accessories

Description	Class	Size SqFt	Eff Yr Blt	RMV	Quantity
No accessory data available					

Bldg: 12 Code Area: 04580 Stat Class: 341 Year Blt: Eff Year Blt: Sq.Ft: 80 % Complete: 100
 Desc: Multi Purpose Shed (MP) Dimensions: 10x8 RMV: 0
 Func Obsc: 100 Econ %: 100 Other %: 100 Exception: 0 Adjust: Adjust RMV: 0

Floors

Type	Class	Display Group	Floor Size	Beds	Baths	Yr Blt	Eff Yr Blt	Inventory	Exception: Y N
Multi-Purpose Bldg	5	Finished	80	0	0	0	0		

Accessories

Description	Class	Size SqFt	Eff Yr Blt	RMV	Quantity
No accessory data available					

Bldg: 13 Code Area: 04580 Stat Class: 341 Year Blt: Eff Year Blt: Sq.Ft: 192 % Complete: 100
 Desc: Multi Purpose Shed (MP) Dimensions: 16x12 RMV: 3760
 Func Obsc: 100 Econ %: 100 Other %: 100 Exception: 0 Adjust: Adjust RMV: 0

Floors

Type	Class	Display Group	Floor Size	Beds	Baths	Yr Blt	Eff Yr Blt	Inventory	Exception: Y N
Multi-Purpose Bldg	4	Finished	192	0	0	0	0		

Accessories

Description	Class	Size SqFt	Eff Yr Blt	RMV	Quantity
No accessory data available					

Bldg: 14 Code Area: 04580 Stat Class: 353 Year Blt: 1983 Eff Year Blt: 1983 Sq.Ft: 3264 % Complete: 100
 Desc: Machine Shed (MS) Dimensions: 96x34 RMV: 11120
 Func Obsc: 100 Econ %: 100 Other %: 100 Exception: 0 Adjust: Adjust RMV: 0

Floors

Type	Class	Display Group	Floor Size	Beds	Baths	Yr Blt	Eff Yr Blt	Inventory	Exception: Y N
Machine Shed	6	Finished	3264	0	0	1983	1983	FAIR	

Accessories

Description	Class	Size SqFt	Eff Yr Blt	RMV	Quantity
No accessory data available					

Bldg: 15 Code Area: 04580 Stat Class: 301 Year Blt: Eff Year Blt: Sq.Ft: 166 % Complete: 100
 Desc: Accessory Improvements & Misc. Dimensions: RMV: 5800
 Func Obsc: 100 Econ %: 100 Other %: 100 Exception: 0 Adjust: Adjust RMV: 0

Floors

Gate part of VI move MAU

Type	Class	Display Group	Floor Size	Beds	Baths	Yr Blt	Eff Yr Blt	Inventory
Building Structure	0	Finished	166	0	0	0	0	Exception: Y N

Accessories

Description	Class	Size SqFt	Eff Yr Blt	RMV	Quantity
No accessory data available					

SKETCH/AREA TABLE ADDENDUM

SUBJECT INFO

File No.: 528204 Parcel No.: 081W12 00100
 Property Address: 14765 WALDO HILLS DR SE
 City: SUBLIMITY County: MARION State: OR ZipCode: 97385
 Owner:
 Client Address:
 Appraiser Name: Inspection Date:

SKETCH

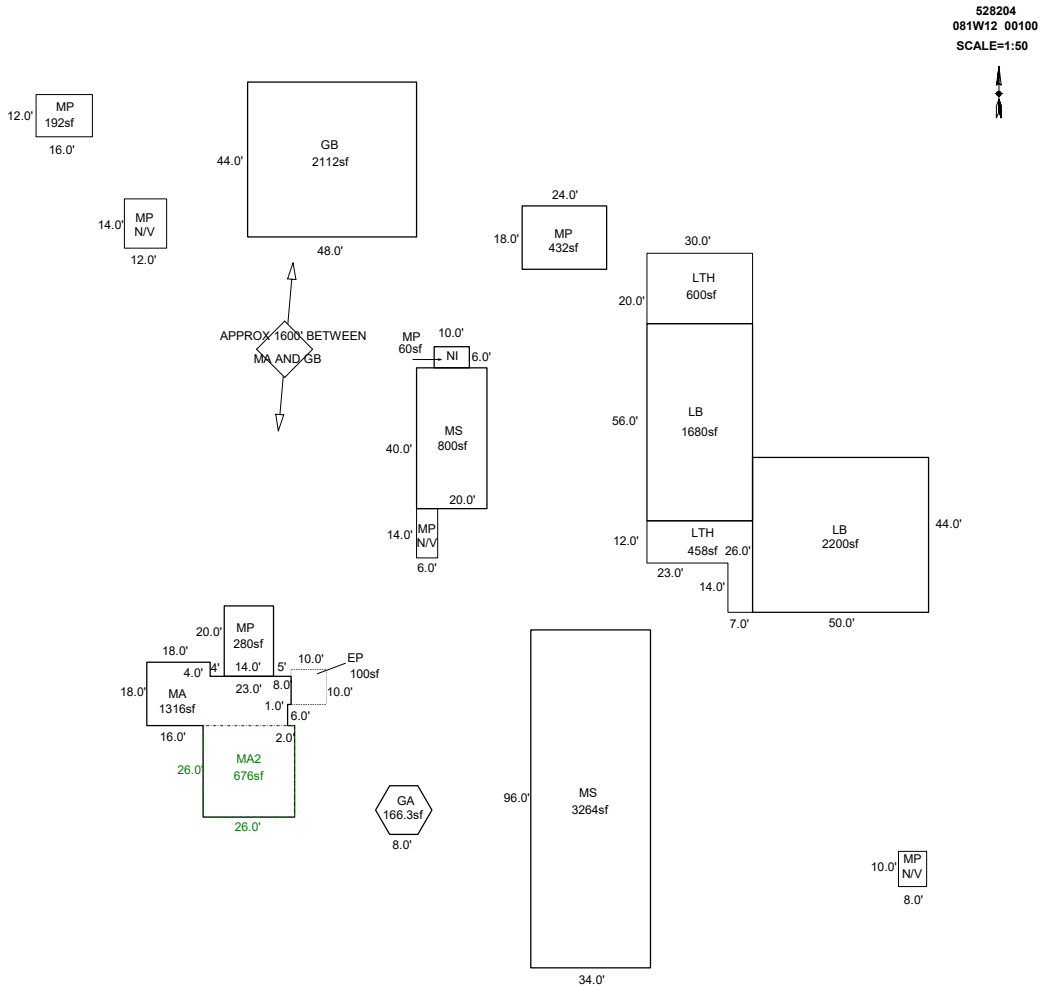

Sketch by ApexSketch

AREA CALCULATIONS SUMMARY						COMMENT TABLE 1	
Code	Description	Factor	Net Size	Perimeter	Net Totals		
GBA1	MP	1.0	432.0	84.0		DRAWN BY JRONDEMA 5/22/17 UPDATED BY JRONDEMA 6/2/17 UPDATED BY CLOBERG 05/07/25	
	LTH	1.0	600.0	100.0			
	GB	1.0	2112.0	184.0			
	MS	1.0	800.0	120.0			
	LB	1.0	1680.0	172.0			
	LB	1.0	2200.0	188.0			
	MP	1.0	60.0	32.0			
	GA	1.0	166.3	48.0			
	MP	1.0	280.0	68.0			
	MS	1.0	3264.0	260.0	11594.3		
GLA1	LTH	1.0	458.0	112.0		4.21.17 SR #94 CYCLE, NV MLH 04/30/25	
	MA	1.0	1316.0	174.0	1774.0		
GLA2	MA2	1.0	676.0	104.0	676.0	CLEAN UP L4	
P/P	EP	1.0	100.0	40.0	100.0		
	Net LIVABLE	cnt	0 (rounded)		2,450		
	Net BUILDING	cnt	10 (rounded)		11,594		

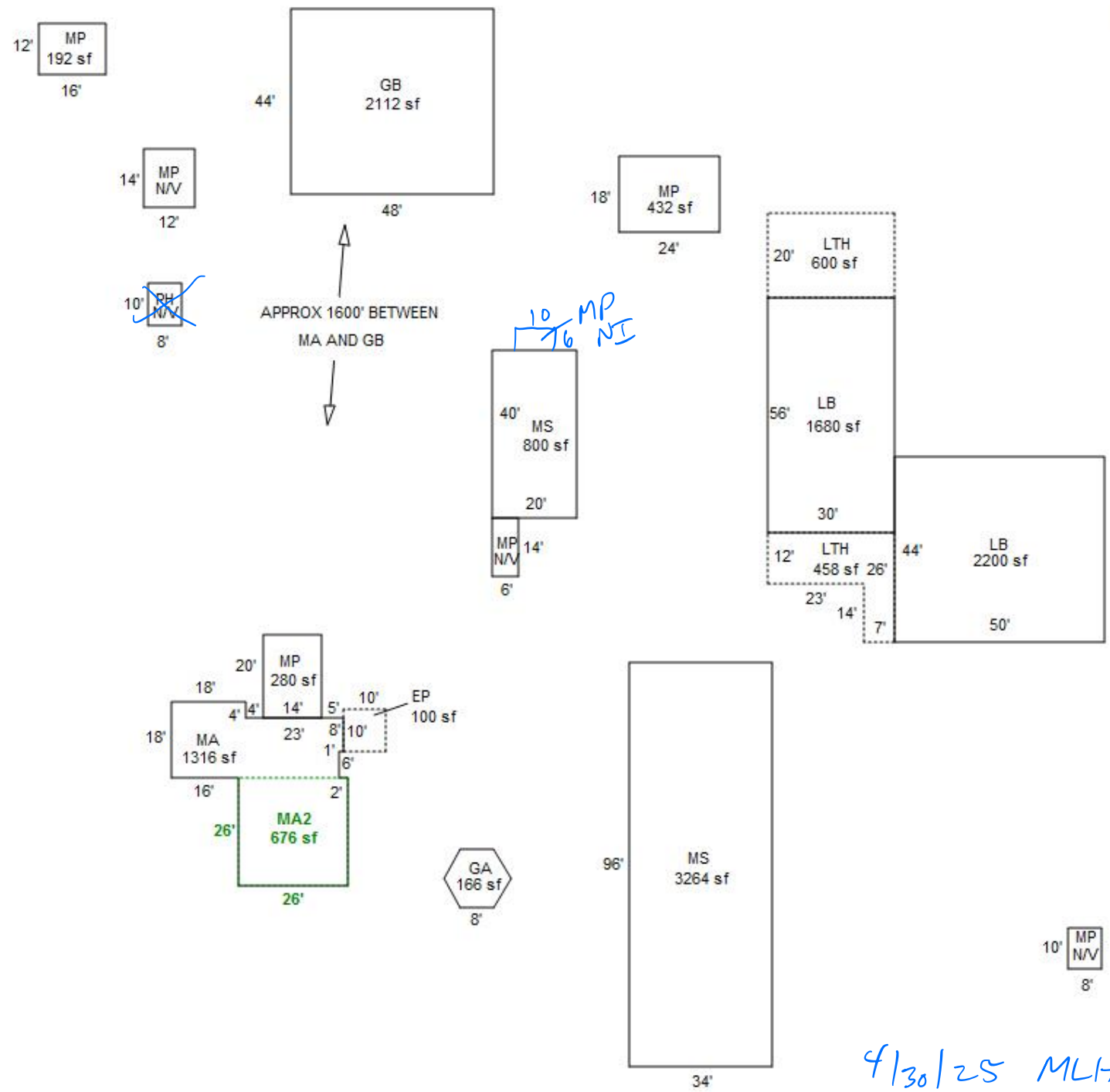



R28204

LB 56X30

LTH 1058 SF

4/21/17



R28204

MS 96X34

4/21/17



R28204

MS 40X20

MP 14X6 N/V

4/21/17



R28204
MP 24X18

4/21/17



R28204

MA & MA2

4/21/17



R28204

GA 308 SF

4/21/17