

SKETCH/AREA TABLE ADDENDUM

SUBJECT INFO

File No.: 323766 Parcel No.: 063W23DB01902
 Property Address: 1020/1020A CLEAR LAKE RD NE
 City: KEIZER County: Marion State: OR ZipCode: 97303
 Owner:
 Client: Client Address:
 Appraiser Name: Inspection Date:

SKETCH

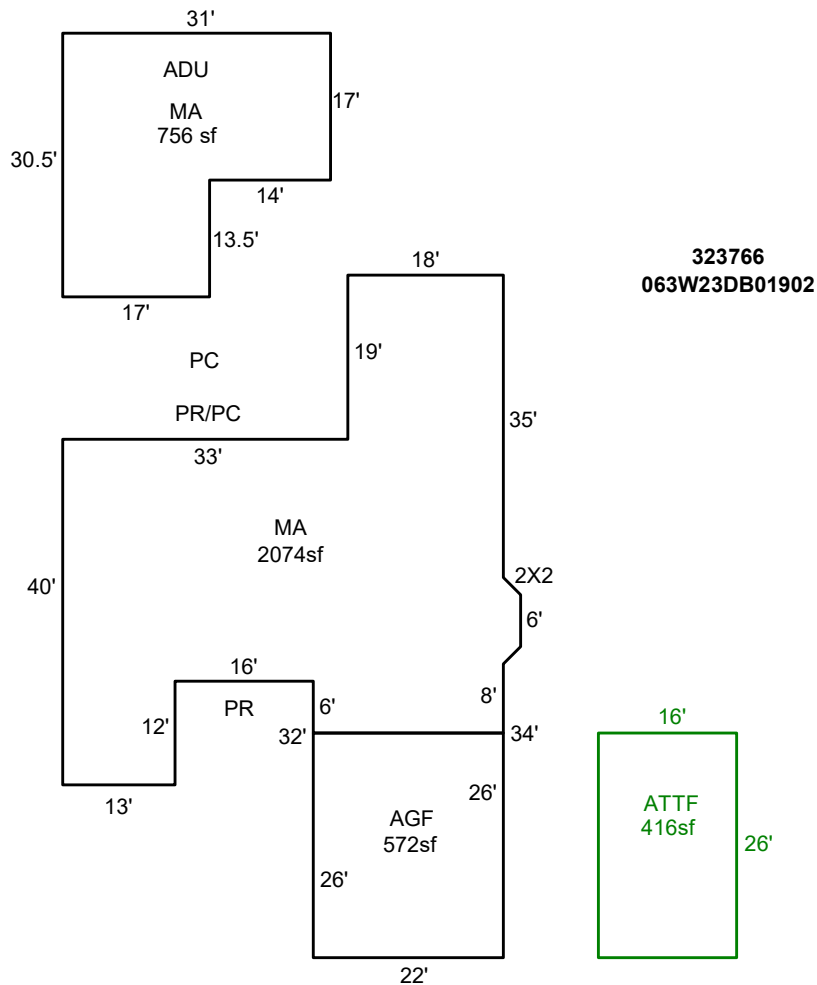

Sketch by ApexSketch

AREA CALCULATIONS SUMMARY

Code	Description	Factor	Net Size	Perimeter	Net Totals
GLA	MA	1.0	2074.0	233.7	
	MA	1.0	756.5	123.0	2830.5
GLA2	ATTF	1.0	416.0	84.0	416.0
GAR	AGF	1.0	572.0	96.0	572.0

COMMENT TABLE 1

DRAWN 08/16/10 BY PL
 Updated by AE 4.29.25

COMMENT TABLE 2

COMMENT TABLE 3

Net LIVABLE cnt 3 (rounded) 3,247