

SKETCH/AREA TABLE ADDENDUM

SUBJECT INFO

File No.: 321382 Parcel No.: 063W23DA10900
 Property Address: 7882 ST CHARLES ST NE
 City: KEIZER County: Marion State: OR ZipCode: 97303
 Owner:
 Client: Client Address:
 Appraiser Name: Inspection Date:

SKETCH

321382
063W23DA10900

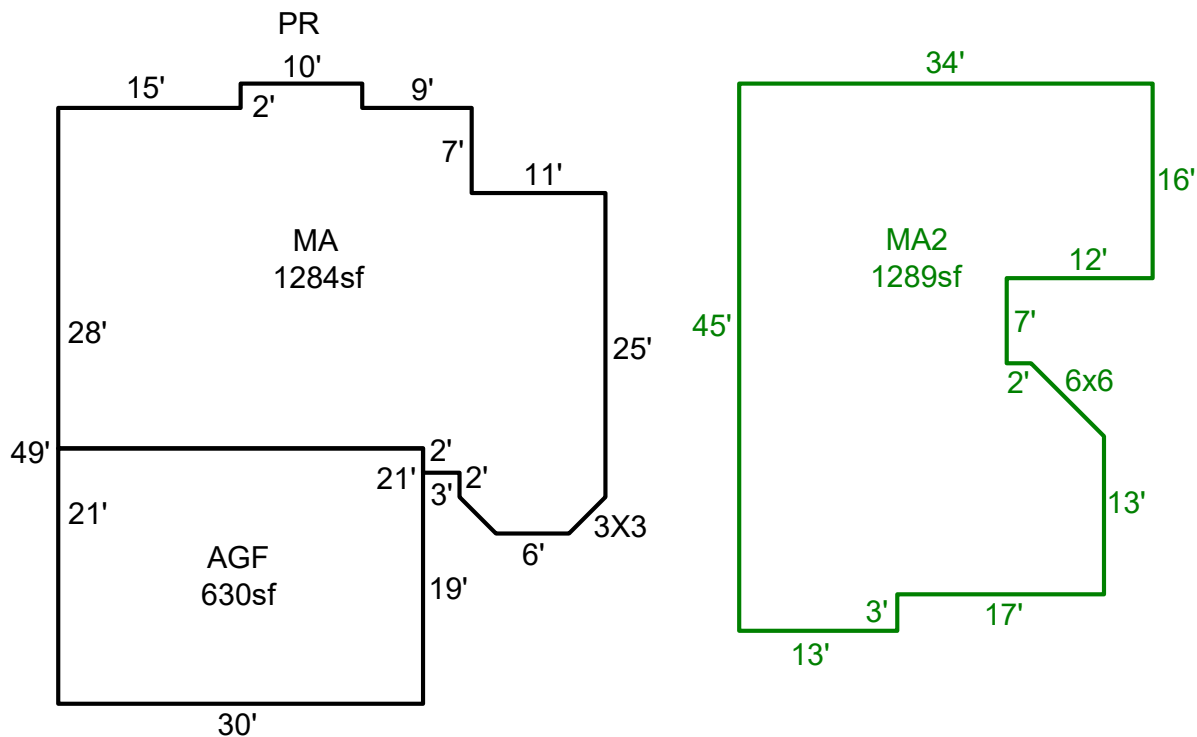

Sketch by ApexSketch

AREA CALCULATIONS SUMMARY

Code	Description	Factor	Net Size	Perimeter	Net Totals
GLA	MA	1.0	1284.0	160.5	1284.0
GLA2	MA2	1.0	1289.0	170.5	1289.0
GAR	AGF	1.0	630.0	102.0	630.0

COMMENT TABLE 1

DRAWN 08/04/10 BY PL
Updated by AE 5.13.25

COMMENT TABLE 2

4/10/18 101 Cycle nv

COMMENT TABLE 3

Net LIVABLE cnt 2 (rounded) 2,573