

Acct ID: 533853 MTL: 091W010000100 Date: 4.28.25 Appr: Genie Prop Class: 551 RMV Prop Class: 551
 Situs: 15233 SPENNER RD SE STAYTON OR 97383 MaSaNh: 01 06 000 Unit: 42905 Year: 2025
 Last Date Appraised: 07/16/2012 Appraiser: CLINT LUKE Retag: Y Tag info:
 Owner: RED ROCK FARM LLC Roll Type: R
 Cycle Tag Sales Verification Other: _____ Inspection level: 1 2 3 4 LCB TTO INSP AV: 138596
 RMV Land: 705190 RMV Imp: 88855 RMV Total: 794045 MAV: 70310 MSAV: 68286 SAV: 122168
 Comment:

INPUT
5-19-25
Genie

Notations

RP/MS	Code	Description
RP	ZONED	FARM EFU ZONED

OSDs

Count	Code	Description	RMV	Code Area	Exception
2	SAF	SA OSD - FAIR	40000	29580	0

NC

Land

Site: 2 Code Area: 29580 Size: 1.00 Acres Use Code: 005 Zone: REST SAV Use: 011 Exception: 0
 Class: Value Source: Farm Homesite Description: RMV: 8190 Exception: Y N
 Adjustment(s): GSOIL, WOOD Fire Patrol: SA004 Description: FIRE PATROL
 Comments: Liability year - 2009 / 2900180

ORLANDO

Site: 3 Code Area: 29580 Size: 48.26 Acres Use Code: 005 Zone: REST SAV Use: 011 Exception: 0
 Class: 2HD Value Source: Farm Use - EFU Description: TWO HILL DRY RMV: 434960 Exception: Y N
 Adjustment(s): GSOIL, WOOD Fire Patrol: SA004 Description: FIRE PATROL
 Comments: Liability year - 1974 / 2900180

Site: 4 Code Area: 29580 Size: 9.00 Acres Use Code: 005 Zone: REST SAV Use: 011 Exception: 0
 Class: 4HD Value Source: Farm Use - EFU Description: FOUR HILL DRY RMV: 73740 Exception: Y N
 Adjustment(s): GSOIL, WOOD Fire Patrol: SA004 Description: FIRE PATROL
 Comments: Liability year - 1974 / 2900180: 01-02; CHANGED SOIL CLASS FROM 3 HILL DRY TO 4 HILL DRY

Site: 5 Code Area: 29580 Size: 18.10 Acres Use Code: 005 Zone: REST SAV Use: 011 Exception: 0
 Class: WOOD Value Source: Woodlot Description: FARM WOODLOT RMV: 148300 Exception: Y N
 Adjustment(s): GSOIL, WOOD Fire Patrol: SA004 Description: FIRE PATROL
 Comments: Liability year - 1974 / 2900000//2012-13: CHG OF SOIL CLASS DURING CYCLE WORK - 6HILL TO WOODLOT AND 4HILL//: 01-02;
 CHANGED SOIL CLASS FROM PASTURE TO 6 HILL, COMBINED LAND SEGMENTS, SAME SOIL CLASS, SAME LIAB YEAR, 37.36 ACRES
 TOTAL /02-03: REAPPRAISAL

Improvements - Residence / Manufactured Structures

Bldg: 1 Code Area: 29580 Stat Class: 122 Year Blt: 1916 Eff Year Blt: 1901 Sq.Ft: 1872 % Complete: 100
 Desc: Multi Story above grade Dimensions: RMV: 68963
 Func Obsc: 100 Econ %: 100 Other %: 100 Exception: 0 Adjust: Adjust RMV: 0

Floors

Type	Class	Display Group	Floor Size	Beds	Baths	Yr Blt	Eff Yr Blt	Inventory	Exception
First Floor	2	Finished	960	1	FB-1	1916	1901	KIT / HVAC, ROOF, BATH - 1	Y N
Attic	2	Finished	912	0	0	1916	1901		Y N

NC

Accessories

Description	Class	Size SqFt	Eff Yr Blt	RMV	Quantity	Exception
ENCLOSED PORCH	2	128	1901	1280	1	Y N

NC

Improvements - Accessory Buildings

Bldg: 2 Code Area: 29580 Stat Class: 341 Year Blt: 1940 Eff Year Blt: 1988 Sq.Ft: 216 % Complete: 100
 Desc: Multi Purpose Shed (MP) Dimensions: 18x12 RMV: 2692
 Func Obsc: 100 Econ %: 100 Other %: 100 Exception: 0 Adjust: Adjust RMV: 0

Floors

Type	Class	Display Group	Floor Size	Beds	Baths	Yr Blt	Eff Yr Blt	Inventory	Exception
Multi-Purpose Bldg	6	Finished	216	0	0	1940	1988	FAIR	Y N

NC

Accessories

Description	Class	Size SqFt	Eff Yr Blt	RMV	Quantity
No accessory data available					

Bldg: 3 Code Area: 29580 Stat Class: 341 Year Blt: 1980 Eff Year Blt: 1980 Sq.Ft: 334 % Complete: 100

Desc: Multi Purpose Shed (MP)					Dimensions: RMV: 2666	
Func Obsc: 100	Econ %: 100	Other %: 100	Exception: 0		Adjust:	Adjust RMV: 0
Floors						
Type	Class	Display Group	Floor Size	Beds	Baths	Yr Blt Eff Yr Blt Inventory
Multi-Purpose Bldg	6	Finished	334	0	0	1980 1980 FAIR
Exception: Y N						

NC

Accessories						
Description	Class	Size SqFt	Eff Yr Blt	RMV	Quantity	
No accessory data available						

Bldg: 4	Code Area: 29580	Stat Class: 341	Year Blt:	Eff Year Blt:	Sq.Ft: 416	% Complete: 100
Desc: Multi Purpose Shed (MP)					Dimensions: 26x16	RMV: 0
Func Obsc: 0	Econ %: 100	Other %: 100	Exception: 0		Adjust:	Adjust RMV: 0

Floors						
Type	Class	Display Group	Floor Size	Beds	Baths	Yr Blt Eff Yr Blt Inventory
Multi-Purpose Bldg	4	Finished	416	0	0	0 0
Exception: Y N						

NC

Accessories						
Description	Class	Size SqFt	Eff Yr Blt	RMV	Quantity	
No accessory data available						

Bldg: 5	Code Area: 29580	Stat Class: 351	Year Blt: 1980	Eff Year Blt: 1980	Sq.Ft: 1250	% Complete: 100
Desc: General Purpose Building (GB)					Dimensions: 50x25	RMV: 5390
Func Obsc: 100	Econ %: 100	Other %: 100	Exception: 0		Adjust:	Adjust RMV: 0

Floors						
Type	Class	Display Group	Floor Size	Beds	Baths	Yr Blt Eff Yr Blt Inventory
General Purpose Bldg	5	Finished	1250	0	0	1980 1980 FAIR
Exception: Y N						

NC

Accessories						
Description	Class	Size SqFt	Eff Yr Blt	RMV	Quantity	
No accessory data available						

Bldg: 6	Code Area: 29580	Stat Class: 351	Year Blt: 1972	Eff Year Blt: 1972	Sq.Ft: 1103 1000	% Complete: 100
Desc: General Purpose Building (GB)					Dimensions: 20x50	RMV: 2778
Func Obsc: 100	Econ %: 100	Other %: 100	Exception: 0		Adjust:	Adjust RMV: 0

Floors						
Type	Class	Display Group	Floor Size	Beds	Baths	Yr Blt Eff Yr Blt Inventory
General Purpose Bldg	4	Finished	1103	0	0	1972 1972 FAM
Exception: Y N						

MS

1000

FAM

Accessories						
Description	Class	Size SqFt	Eff Yr Blt	RMV	Quantity	
No accessory data available						

Bldg: 7	Code Area: 29580	Stat Class: 355	Year Blt:	Eff Year Blt:	Sq.Ft: 392 34	% Complete: 100
Desc: Lean-to Heavy (LTH)					Dimensions: 28x14	RMV: 0
Func Obsc: 0	Econ %: 100	Other %: 100	Exception: 0		Adjust:	Adjust RMV: 0

Floors						
Type	Class	Display Group	Floor Size	Beds	Baths	Yr Blt Eff Yr Blt Inventory
Lean-to Heavy Duty	4	Finished	392	0	0	0 0
Exception: Y N						

GB

FAM

Accessories						
Description	Class	Size SqFt	Eff Yr Blt	RMV	Quantity	
No accessory data available						

Bldg: 8	Code Area: 29580	Stat Class: 353	Year Blt:	Eff Year Blt:	Sq.Ft: 680	% Complete: 100
Desc: Machine Shed (MS)					Dimensions: 34x20	RMV: 0
Func Obsc: 0	Econ %: 100	Other %: 100	Exception: 0		Adjust:	Adjust RMV: 0

Floors						
Type	Class	Display Group	Floor Size	Beds	Baths	Yr Blt Eff Yr Blt Inventory
Machine Shed	4	Finished	680	0	0	0 0
Exception: Y N						

NC

Accessories						
Description	Class	Size SqFt	Eff Yr Blt	RMV	Quantity	
No accessory data available						

Bldg: 9	Code Area: 29580	Stat Class: 351	Year Blt: 1989	Eff Year Blt: 1989	Sq.Ft: 800	% Complete: 100
Desc: General Purpose Building (GB)					Dimensions: 40x20	RMV: 3256
Func Obsc: 100	Econ %: 100	Other %: 100	Exception: 0		Adjust:	Adjust RMV: 0

Floors										
Type	Class	Display Group	Floor Size	Beds	Baths	Yr Blt	Eff Yr Blt	Inventory	NC	
General Purpose Bldg	4	Finished	800	0	0	1989	1989	FAIR	Exception: Y N	

Accessories										
Description	Class	Size	SqFt	Eff Yr Blt	RMV	Quantity				
No accessory data available										

Bldg: 10 Code Area: 29580 Stat Class: 311 Year Blt: 1961 Eff Year Blt: 1961 Sq.Ft: 1520 % Complete: 100
 Desc: Feeder Barn (FB) Dimensions: 40x38 RMV: 3110
 Func Obsc: 100 Econ %: 100 Other %: 100 Exception: 0 Adjust: Adjust RMV: 0

Floors										
Type	Class	Display Group	Floor Size	Beds	Baths	Yr Blt	Eff Yr Blt	Inventory		
Feeder Barn	4	Finished	1520	0	0	1961	1961	FAIR	Exception: Y N	

Accessories										
Description	Class	Size	SqFt	Eff Yr Blt	RMV	Quantity	Loft = NV - NI			
No accessory data available										

SKETCH/AREA TABLE ADDENDUM

SUBJECT INFO

File No.: 533853 Parcel No.: 091W01 00100
 Property Address: 15233 Spenner Rd SE
 City: Stayton County: State: OR ZipCode: 97383
 Owner:
 Client: Client Address:
 Appraiser Name: Inspection Date:

SKETCH

533853
091W01 00100

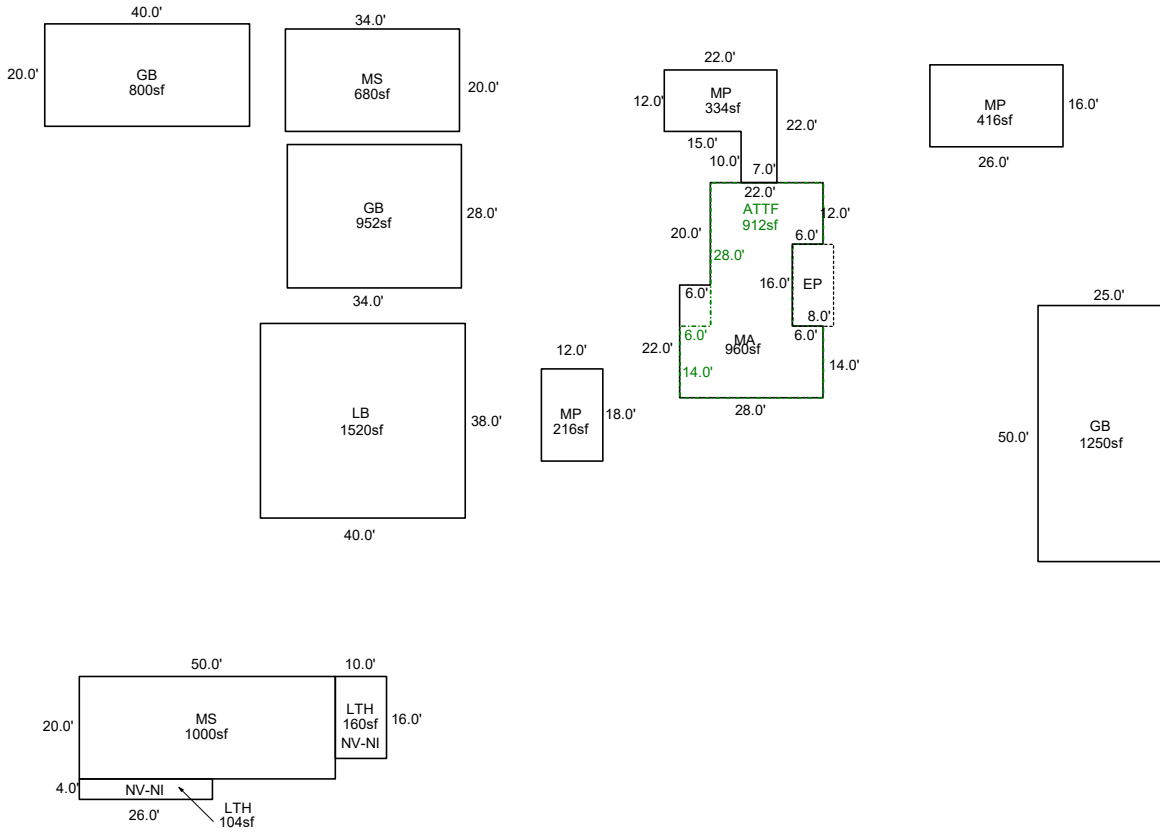

Sketch by ApexSketch

AREA CALCULATIONS SUMMARY

Code	Description	Factor	Net Size	Perimeter	Net Totals
GBA1	LB	1.0	1520.0	156.0	
	MP	1.0	334.0	88.0	
	MP	1.0	416.0	84.0	
	GB	1.0	1250.0	150.0	
	MS	1.0	680.0	108.0	
	GB	1.0	800.0	120.0	
	MP	1.0	216.0	60.0	
	GB	1.0	952.0	124.0	
	MS	1.0	1000.0	140.0	
	LTH	1.0	104.0	60.0	
	LTH	1.0	160.0	52.0	7432.0
	GLA1	MA	1.0	960.0	152.0
GLA2	ATTF	1.0	912.0	152.0	912.0
P/P	EP	1.0	128.0	48.0	128.0
	Net LIVABLE	cnt	0 (rounded)		1,872
	Net BUILDING	cnt	11 (rounded)		7,432

COMMENT TABLE 1

Apex 7/18/2012 Jane
 UPDATED BY CLOBERG 05/12/25

COMMENT TABLE 2

CLUKE 04/28/25

COMMENT TABLE 3

CYCLE L4