

Acct ID: 534727 MTL: 091W12D000400 Date: 3-25-25 Appr: CEVCE Prop Class: 451 RMV Prop Class: 451
 Situs: 10632 MINTEN LN SE STAYTON OR 97383 MaSaNh: 01 06 000 Unit: 35451 Year: 2025
 Last Date Appraised: 09/12/2012 Appraiser: CLINT LUKE Retag: Y 4 Tag info: INPUT 4-17-25 CEVCE
 Owner: WAGNER, ANITA E & WAGNER, JAMES B D Roll Type: R
 Cycle 1 Tag Sales Verification Other: _____ Inspection level: 1 2 3 1 LCB TTO INSP AV: 95350
 RMV Land: 259270 RMV Imp: 81030 RMV Total: 340300 MAV: 95350 MSAV: 0 SAV: 0
 Comment:

Notations
 No notation data available.

OSDs

Count	Code	Description	RMV	Code Area	Exception
1	MKTF	OSD - FAIR	40000	29540	0
1	SEPTC	SEPTIC SYSTEM	13500	29540	0

NC

Land

Site: 1 Code Area: 29540 Size: 0.68 Acres Use Code: 005 Zone: REST SAV Use: Exception: 0
 Class: 2BDS Value Source: Rural Restrictive Description: TWO BENCH DRY SOUTH SPECIAL RMV: 205770 Exception: Y N
 Adjustment(s): GSOIL Fire Patrol: Description:
 Comments: 2002-03 REAPP. //F07-581 ACREAGE AND MAP CORRECTION ON R34727,R34726,R34725 - NO MOVEMENT OF IMPS

Improvements - Residence / Manufactured Structures

Bldg: 1 Code Area: 29540 Stat Class: 121 Year Blt: 1930 Eff Year Blt: 1953 Sq.Ft: 952 % Complete: 100
 Desc: One Story Only Dimensions: RMV: 70820
 Func Obsc: 100 Econ %: 100 Other %: 100 Exception: 0 Adjust: Adjust RMV: 0

Floors

Type	Class	Display Group	Floor Size	Beds	Baths	Yr Blt	Eff Yr Blt	Inventory	Exception
First Floor	2	Finished	952	1	FB-1	1930	1953	HVAC, ROOF, BATH - 1, KIT-	Y N

NC

Accessories

Description	Class	Size SqFt	Eff Yr Blt	RMV	Quantity
No accessory data available					

Improvements - Accessory Buildings

Bldg: 2 Code Area: 29540 Stat Class: 341 Year Blt: 1986 Eff Year Blt: 1986 Sq.Ft: 416 % Complete: 100
 Desc: Multi Purpose Shed (MP) Dimensions: 26x16 RMV: 3710
 Func Obsc: 100 Econ %: 100 Other %: 100 Exception: 0 Adjust: Adjust RMV: 0

Floors

Type	Class	Display Group	Floor Size	Beds	Baths	Yr Blt	Eff Yr Blt	Inventory	Exception
Multi-Purpose Bldg	6	Finished	416	0	0	1986	1986	FAIR	Y N

NC

Accessories

Description	Class	Size SqFt	Eff Yr Blt	RMV	Quantity
No accessory data available					

Bldg: 3 Code Area: 29540 Stat Class: 341 Year Blt: 1979 Eff Year Blt: 1979 Sq.Ft: 312 % Complete: 100
 Desc: Multi Purpose Shed (MP) Dimensions: 26x12 RMV: 2240
 Func Obsc: 100 Econ %: 100 Other %: 100 Exception: 0 Adjust: Adjust RMV: 0

Floors

Type	Class	Display Group	Floor Size	Beds	Baths	Yr Blt	Eff Yr Blt	Inventory	Exception
Multi-Purpose Bldg	6	Finished	312	0	0	1979	1979		Y N

Accessories

Description	Class	Size SqFt	Eff Yr Blt	RMV	Quantity
No accessory data available					

Bldg: 4 Code Area: 29540 Stat Class: 341 Year Blt: 2005 Eff Year Blt: 2005 Sq.Ft: 120 % Complete: 100
 Desc: Multi Purpose Shed (MP) Dimensions: 10x12 RMV: 1850
 Func Obsc: 100 Econ %: 100 Other %: 100 Exception: 0 Adjust: Adjust RMV: 0

Floors

NC

Type	Class	Display Group	Floor Size	Beds	Baths	Yr Blt	Eff Yr Blt	Inventory	Exception: Y N
Multi-Purpose Bldg	5	Finished	120	0	0	2005	2005	FAM	

Accessories

Description	Class	Size SqFt	Eff Yr Blt	RMV	Quantity
No accessory data available					

Bldg: 5	Code Area: 29540	Stat Class: 341	Year Blt: 2005	Eff Year Blt: 2005	Sq.Ft: 208	% Complete: 100
Desc: Multi Purpose Shed (MP)			Dimensions: RMV: 2410			
Func Obsc: 100	Econ %: 100	Other %: 100	Exception: 0	Adjust:	Adjust RMV: 0	

Floors

Type	Class	Display Group	Floor Size	Beds	Baths	Yr Blt	Eff Yr Blt	Inventory	Exception: Y N
Multi-Purpose Bldg	4	Finished	208	0	0	2005	2005	FAM	

NC

Accessories

Description	Class	Size SqFt	Eff Yr Blt	RMV	Quantity
No accessory data available					

SKETCH/AREA TABLE ADDENDUM

SUBJECT INFO

File No.: 534727 Parcel No.: 091W12D 00400
 Property Address: 10632 Minten Ln SE
 City: Stayton County: State: OR ZipCode: 97383
 Owner:
 Client: Client Address:
 Appraiser Name: Inspection Date:

SKETCH

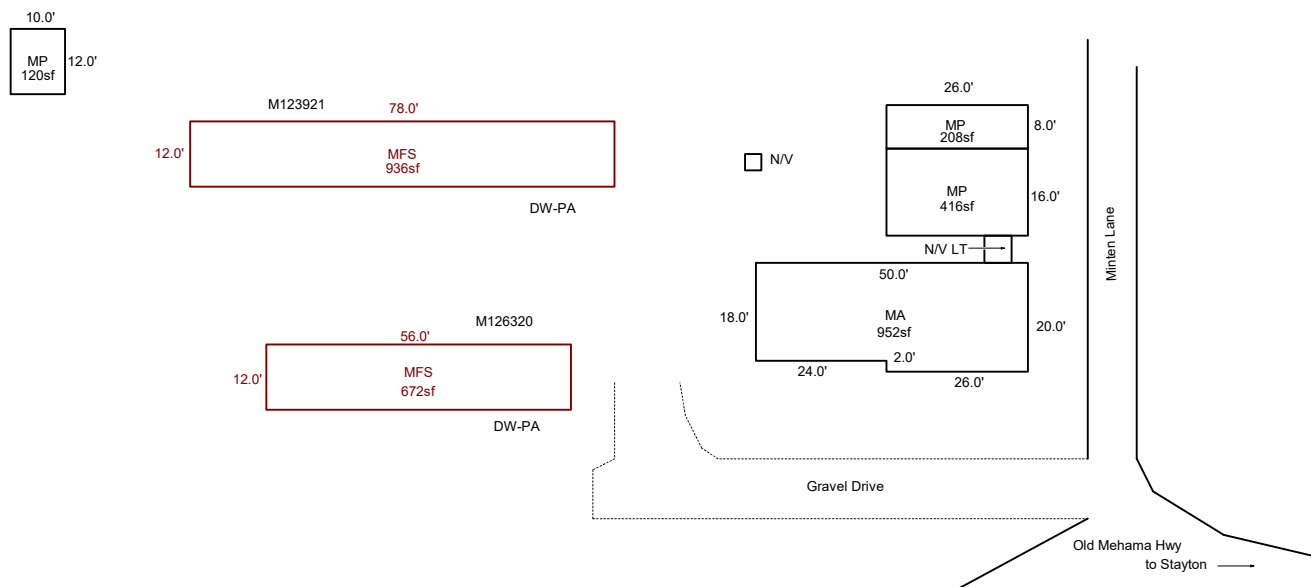

Sketch by ApexSketch

AREA CALCULATIONS SUMMARY						COMMENT TABLE 1	
Code	Description	Factor	Net Size	Perimeter	Net Totals		
GBA1	MP	1.0	208.0	68.0		Apex 11/29/12Jane UPDATED BY CLOBERG 04/15/25	
	MP	1.0	416.0	84.0			
	N/V LT	1.0	25.0	20.0			
	MP	1.0	120.0	44.0	769.0		
GLA1	MA	1.0	952.0	140.0			
	MFS	1.0	936.0	180.0			
	MFS	1.0	672.0	136.0	2560.0		
	Net LIVABLE	cnt	0 (rounded)		2,560		
	Net BUILDING	cnt	4 (rounded)		769		
						COMMENT TABLE 2	COMMENT TABLE 3
						CLUKE 03/25/25	CYCLE L4