

Acct ID: 534767 MTL: 091W12D000900 Date: 3-25-25 Appr: LUKE Prop Class: 551 RMV Prop Class: 551
 Situs: 10842 MINTEN LN SE STAYTON OR 97383 MaSaNh: 01 06 000 Unit: 39147 **INPUT 4-8-25 LUKE** Year: 2025
 Last Date Appraised: 09/12/2012 Appraiser: CLINT LUKE Retag: Y N Tag info: _____
 Owner: MINTEN, RALPH J Roll Type: R
 Cycle Tag Sales Verification Other: _____ Inspection level: 1 2 3 4 LCB TTO INSP AV: 127089
 RMV Land: 448590 RMV Imp: 235870 RMV Total: 684460 MAV: 94600 MSAV: 32489 SAV: 69693
 Comment: _____

Notations

RP/MS	Code	Description
RP	ZONED	FARM EFU ZONED

OSDs

Count	Code	Description	RMV	Code Area	Exception
2	SAA	SA OSD - AVERAGE	50000	29540	0

Land

FRAMON BY MARGIBON HAS CATTLE + SHEEP

Site: 2 Code Area: 29540 Size: 1.00 Acres Use Code: 005 Zone: REST SAV Use: 011 Exception: 0
 Class: 2BDS Value Source: Farm Homesite Description: TWO BENCH DRY SOUTH SPECIAL RMV: 34290 Exception: Y N
 Adjustment(s): GSOIL, IRR, WASTE Fire Patrol: SA004 Description: FIRE PATROL
 Comments: Liability year - 2009 / 2900040

Site: 3 Code Area: 29540 Size: 5.50 Acres Use Code: 005 Zone: REST SAV Use: 011 Exception: 0
 Class: 2BISS Value Source: Farm Use - EFU Description: TWO BENCH IRR SOUTH SPECIAL RMV: 197150 Exception: Y N
 Adjustment(s): GSOIL, IRR, WASTE Fire Patrol: SA004 Description: FIRE PATROL
 Comments: Liability year - 1980 / 2900040

Site: 4 Code Area: 29540 Size: 5.00 Acres Use Code: 005 Zone: REST SAV Use: 011 Exception: 0
 Class: 4BISS Value Source: Farm Use - EFU Description: FOUR BENCH IRR SPECIAL SOUTH RMV: 163640 Exception: Y N
 Adjustment(s): GSOIL, IRR, WASTE Fire Patrol: SA004 Description: FIRE PATROL
 Comments: Liability year - 1980

Site: 5 Code Area: 29540 Size: 2.11 Acres Use Code: 005 Zone: REST SAV Use: 011 Exception: 0
 Class: WST Value Source: WASTE RURAL Description: Rural WASTELAND RMV: 1970 Exception: Y N
 Adjustment(s): GSOIL, IRR, WASTE Fire Patrol: SA004 Description: FIRE PATROL
 Comments: Liability year - 1980 / //08-09: Market wasteland study by GW39 - change from wasteland to wasteland-M//2900000 02-03: REAPPRAISAL 06-07: PART TOTALS UPDATED 06-07: F05-0674 ACREAGE CORRECTIONS INVOLVING R34719, R34720, R34766, R34767. POSTED AS LLA'S.

Site: 6 Code Area: 29540 Size: 1.65 Acres Use Code: 005 Zone: REST SAV Use: 011 Exception: 0
 Class: WST Value Source: WASTE RURAL Description: Rural WASTELAND RMV: 1540 Exception: Y N
 Adjustment(s): GSOIL, IRR, WASTE Fire Patrol: SA004 Description: FIRE PATROL
 Comments: Liability year - 1999 / 99-2000: F99-42 ADD FOR RIVER 06-07: F05-0674 ACREAGE CORRECTIONS INVOLVING R34719, R34720, R34766, R34767. POSTED AS LLA'S.

Improvements - Residence / Manufactured Structures

Bldg: 1 Code Area: 29540 Stat Class: 134 Year Blt: 1930 Eff Year Blt: 1930 Sq.Ft: 1680 % Complete: 100
 Desc: Multi Story above grade with basement Dimensions: RMV: 172320
 Func Obsc: 100 Econ %: 100 Other %: 100 Exception: 0 Adjust: Adjust RMV: 0

Floors

Type	Class	Display Group	Floor Size	Beds	Baths	Yr Blt	Eff Yr Blt	Inventory	Exception
First Floor	3	Finished	1060	2	FB-1	1930	1930	KIT, FP - 1, HVAC, ROOF, BATH - 1	Y N
Attic	3	Finished	620	3	0	1930	1930	HVAC	Y N
Basement	3	Unfinished	1040	0	0	1930	1930		Y N

Accessories

Description	Class	Size SqFt	Eff Yr Blt	RMV	Quantity	Exception
YARD IMPROVEMENTS FAIR	3	1	1930	6206	1	Y N

Bldg: 2 Code Area: 29540 Stat Class: 138 Year Blt: 1977 Eff Year Blt: 1937 Sq.Ft: 24x24 576 % Complete: 100
 Desc: Res other improvements Dimensions: RMV: 39840
 Func Obsc: 100 Econ %: 100 Other %: 100 Exception: 0 Adjust: Adjust RMV: 0

Floors

Type	Class	Display Group	Floor Size	Beds	Baths	Yr Blt	Eff Yr Blt	Inventory	Exception
Garage Detached	3	Unfinished	<u>864</u>	0	0	1977	1937	ROOF	Y N

LTE 12x24 1999 1/0

Accessories

Description	Class	Size SqFt	Eff Yr Blt	RMV	Quantity
No accessory data available					

Bldg: 3 Code Area: 29540 Stat Class: 138 Year Blt: 1977 Eff Year Blt: 1937 Sq.Ft: 0 % Complete: 100
Desc: Res other improvements Dimensions: RMV: 23710
Func Obsc: 100 Econ %: 100 Other %: 100 Exception: 0 Adjust: Adjust RMV: 0

Floors

Type	Class	Display Group	Floor Size	Beds	Baths	Yr Blt	Eff Yr Blt	Inventory	Exception: Y N
Carport Detached	3	Unfinished	880	0	0	1977	1937	ROOF	

GONB

Accessories

Description	Class	Size SqFt	Eff Yr Blt	RMV	Quantity
No accessory data available					

Improvements - Accessory Buildings

No improvement data available for all other stat class types.

SKETCH/AREA TABLE ADDENDUM

SUBJECT INFO

File No.: 534767 Parcel No.: 091W12D 00900
 Property Address: 10842 MINTEN LN SE
 City: STAYTON County: MARION State: OR ZipCode: 97383
 Owner:
 Client: Client Address:
 Appraiser Name: Inspection Date:

SKETCH

534767
091W12D 00900
SCALE=1:50

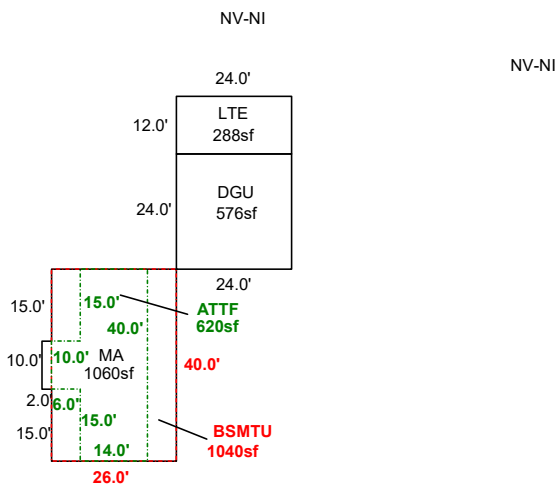
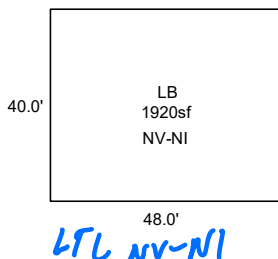

Sketch by ApexSketch

AREA CALCULATIONS SUMMARY						COMMENT TABLE 1	
Code	Description	Factor	Net Size	Perimeter	Net Totals		
GBA1	LTE	1.0	288.0	72.0	288.0	DRAWN BY JRONDEMA 5/17/18 UPDATED BY CLOBERG 03/31/25	
GLA1	MA	1.0	1060.0	136.0	1060.0		
GLA2	ATTF	1.0	620.0	120.0	620.0		
BSMT	BSMTU	1.0	1040.0	132.0	1040.0		
GAR	DGU	1.0	576.0	96.0	576.0		
						COMMENT TABLE 2	COMMENT TABLE 3
						CLUKE 03/25/25	CYCLE L4
Net LIVABLE		cnt	0	(rounded)	1,680		
Net BUILDING		cnt	1	(rounded)	288		