

Acct ID: 535745 MTL: 092W28B000900 Date: 4/22/25 Appr: MLH Prop Class: 649 RMV Prop Class: 649
 Situs: 13105 MOUNTAIN VIEW LN SE TURNER OR 97392 MaSaNh: 07 06 000 Unit: 55986 Year: 2025

Last Date Appraised: 03/27/2014 Appraiser: MATT LORD Retag: Y N Tag info:

Owner: BIRCH, MORGAN & BIRCH, DARCIE Roll Type: R

Cycle Tag Sales Verification Other: Clean Up Inspection level: 1 2 3 4 LCB TTO INSP AV: 244141

RMV Land: 323630 RMV Imp: 259380 RMV Total: 583010 MAV: 242320 MSAV: 1821 SAV: 3530

Comment:

Input MLH 5/30/25

Notations

RP/MS	Code	Description	Forest OK
MS	DFL	DESIGNATED FORESTLAND	
MS	DFL	DESIGNATED FORESTLAND	

OSDs

Count	Code	Description	RMV	Code Area	Exception
1	MKTF	OSD - FAIR	40000	05530	0

Land

AVE

Site: 1 Code Area: 05530 Size: 1.00 Acres Use Code: 004 Zone: NREST SAV Use: Exception: 0
 Class: 4HD Value Source: Market Homesite Description: FOUR HILL DRY RMV: 83070 Exception: Y N
 Adjustment(s): VWAR Fire Patrol: Description:
 Comments: 16-17: COMB LIKE SEGS // 09-10: CYCLE WORK PER #49 CHG VIEWG.RUR TO VIEWA.RUR// 03-04: REAPP, 00500130

Site: 2 Code Area: 05530 Size: 3.18 Acres Use Code: 004 Zone: NREST SAV Use: 011 Exception: 0
 Class: FTLC Value Source: Designated Forest Land Description: DFL Class C RMV: 200560 Exception: Y N
 Adjustment(s): VWAR Fire Patrol: Description:
 Comments: Liability year - 1996 / 00500130 //2012-13: ROLL FROM FARM TO DFL IN 2000//

Improvements - Residence / Manufactured Structures

2001 M/M

Bldg: 4 Code Area: 05530 Stat Class: 148 Year Blt: 1993 Eff Year Blt: 1993 Sq.Ft: 0 % Complete: 100
 Desc: Res other improvements Dimensions: RMV: 64450
 Func Obsc: 100 Econ %: 100 Other %: 100 Exception: 0 Adjust: Adjust RMV: 0

Floors

Type	Class	Display Group	Floor Size	Beds	Baths	Yr Blt	Eff Yr Blt	Inventory	Exception
Garage Detached	4	Unfinished	768	0	0	1993	1993	ROOF _{Sf} I/O	Exception: Y N
<u>addn</u>			<u>384</u>			<u>M/M</u>	<u>2023</u>		

Accessories

Description	Class	Size SqFt	Eff Yr Blt	RMV	Quantity
No accessory data available					

Bldg: 5 Code Area: 05530 Stat Class: 465 + Year Blt: 2012 Eff Year Blt: 2012 Sq.Ft: 2094 % Complete: 100
 Desc: MANUF STRUCT, CLASS 6, 20' WIDE DOUBLE Dimensions: RMV: 193850
 Func Obsc: 100 Econ %: 100 Other %: 100 Exception: 0 Adjust: Adjust RMV: 0

I/O

Floors

Type	Class	Display Group	Floor Size	Beds	Baths	Yr Blt	Eff Yr Blt	Inventory	Exception
First Floor	6 +	Finished	2094	3	FB-2	2012	2012	HVAC+, SKRT+, KIT <u>Roof+ 2 Bath</u>	Exception: Y N

Accessories

Description	Class	Size SqFt	Eff Yr Blt	RMV	Quantity
DECK Part of YI	6	432	2013	8649	0
Exception: Y N					

Improvements - Accessory Buildings

Bldg: 1 Code Area: 05530 Stat Class: 341 Year Blt: Eff Year Blt: Sq.Ft: 42 % Complete: 100
 Desc: Multi Purpose Shed (MP) Dimensions: 7x6 RMV: 0
 Func Obsc: 0 Econ %: 100 Other %: 100 Exception: 0 Adjust: Adjust RMV: 0

NC

Floors

Type	Class	Display Group	Floor Size	Beds	Baths	Yr Blt	Eff Yr Blt	Inventory	Exception
Multi-Purpose Bldg	5	Finished	42	0	0	0	0	FAIR	Exception: Y N

Accessories

Description	Class	Size SqFt	Eff Yr Blt	RMV	Quantity
No accessory data available					

Bldg: 2 Code Area: 05530 Stat Class: 341 Year Blt: Eff Year Blt: Sq.Ft: 96 % Complete: 100
 Desc: Multi Purpose Shed (MP) Dimensions: 12x8 RMV: 0
 Func Obsc: 0 Econ %: 100 Other %: 100 Exception: 0 Adjust: Adjust RMV: 0

NC

Floors

Type	Class	Display Group	Floor Size	Beds	Baths	Yr Blt	Eff Yr Blt	Inventory	Exception: Y N
Multi-Purpose Bldg	4	Finished	96	0	0	0	0		

Accessories

Description	Class	Size SqFt	Eff Yr Blt	RMV	Quantity
No accessory data available					

Bldg: 3 Code Area: 05530 Stat Class: 301 Year Blt: Eff Year Blt: Sq.Ft: 110 % Complete: 100
 Desc: Accessory Improvements & Misc. [Chng to LTL](#) Dimensions: 11x10 RMV: 0
 Func Obsc: 0 Econ %: 100 Other %: 100 Exception: 0 Adjust: Adjust RMV: 0

Floors

Type	Class	Display Group	Floor Size	Beds	Baths	Yr Blt	Eff Yr Blt	Inventory	Exception: Y N
Building Structure	0	Finished	110	0	0	0	0		

Accessories

Description	Class	Size SqFt	Eff Yr Blt	RMV	Quantity
No accessory data available					

Bldg: 6 Code Area: 05530 Stat Class: 356 Year Blt: 2013 Eff Year Blt: 2013 Sq.Ft: 128 % Complete: 100
 Desc: Lean-to Excellent (LTE) [Part of YI, move MAV](#) Dimensions: 16x8 RMV: 1080
 Func Obsc: 100 Econ %: 100 Other %: 100 Exception: 0 Adjust: Adjust RMV: 0

Floors

Type	Class	Display Group	Floor Size	Beds	Baths	Yr Blt	Eff Yr Blt	Inventory	Exception: Y N
Lean-to Excellent	4	Finished	128	0	0	2013	2013		

Accessories

Description	Class	Size SqFt	Eff Yr Blt	RMV	Quantity
No accessory data available					

Break out YIs for Manuf
 107 YI 3G 2012

SKETCH/AREA TABLE ADDENDUM

SUBJECT INFO

File No.: 535745 Parcel No.: 092W28B 00900
 Property Address: 13105 MOUNTAIN VIEW LN SE
 City: TURNER County: State: OR ZipCode: 97392
 Owner:
 Client: Client Address:
 Appraiser Name: Inspection Date:

SKETCH

535745
092W28B 00900

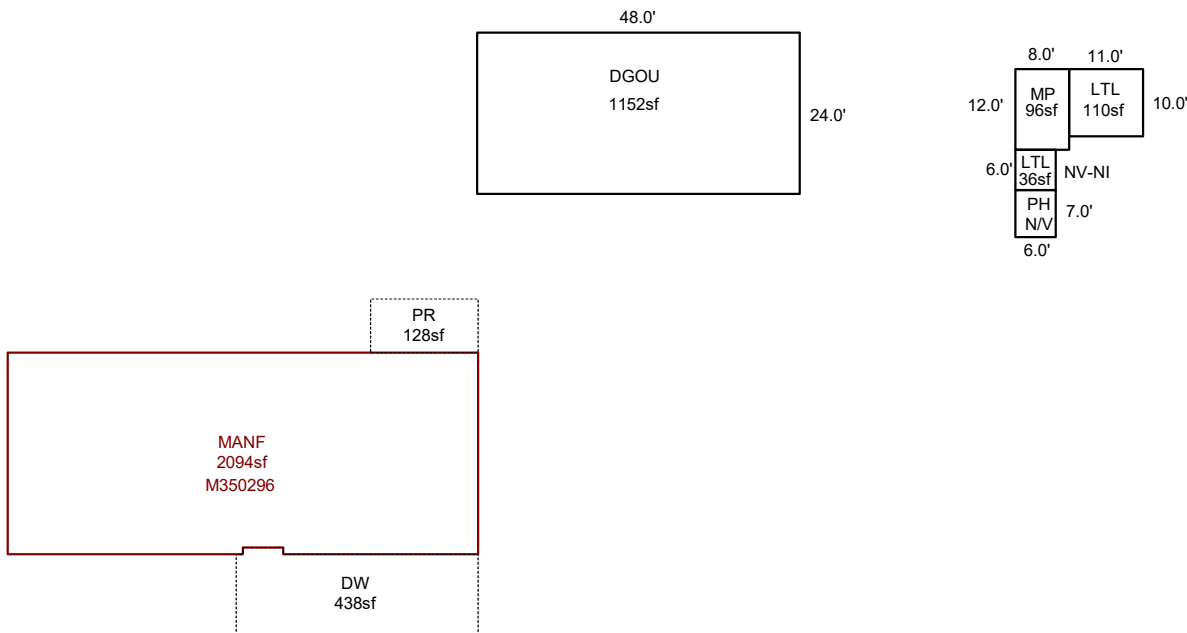

See Page 2 for MFH Dimensions

Sketch by ApexSketch

AREA CALCULATIONS SUMMARY						COMMENT TABLE 1		
Code	Description	Factor	Net Size	Perimeter	Net Totals			
GBA1	MP	1.0	96.0	40.0		APEXED BY CE 2/22/10 UPDATED BY CLOBERG 05/12/25		
	LTL	1.0	36.0	24.0	132.0			
GAR	DGOU	1.0	1152.0	144.0	1152.0			
MANF	MANF	1.0	2094.0	202.0	2094.0			
OTH	LTL	1.0	110.0	42.0	110.0			
P/P	DW	1.0	438.0	98.0				
	PR	1.0	128.0	48.0	566.0			
Net LIVABLE						cnt	1 (rounded)	2,094
Net BUILDING						cnt	2 (rounded)	132

COMMENT TABLE 2	COMMENT TABLE 3
MLH 04/22/25	CLEAN UP L4

SKETCH/AREA TABLE ADDENDUM

SUBJECT INFO

File No.: 535745 Parcel No.: 092W28B 00900
 Property Address: 13105 MOUNTAIN VIEW LN SE
 City: TURNER County: State: OR ZipCode: 97392
 Owner:
 Client: Client Address:
 Appraiser Name: Inspection Date:

SKETCH

535745
092W28B 00900

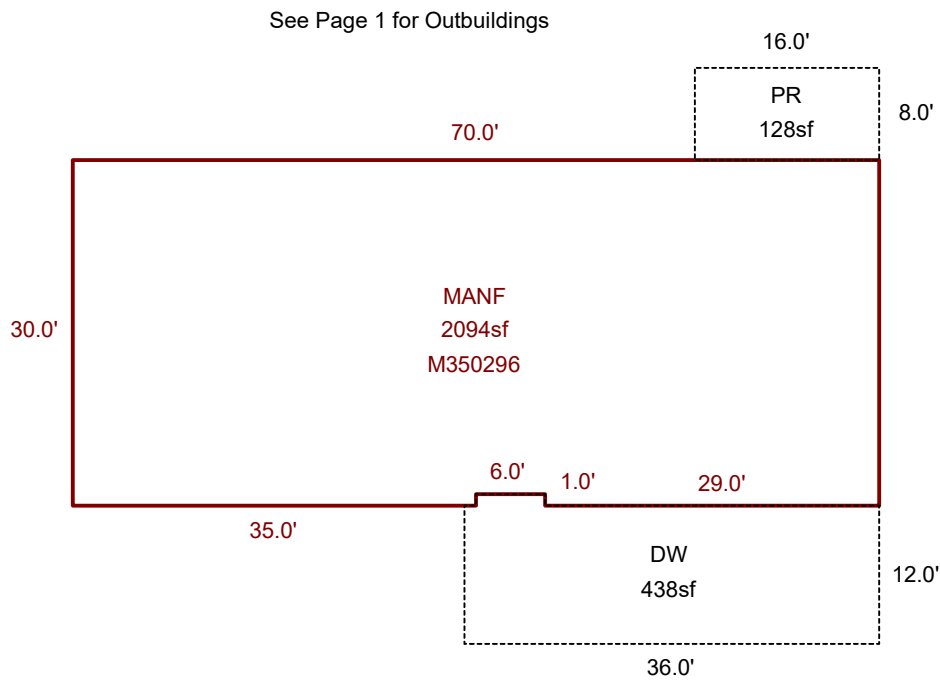

Sketch by ApexSketch

AREA CALCULATIONS SUMMARY

Code	Description	Factor	Net Size	Perimeter	Net Totals
MANF	MANF	1.0	2094.0	202.0	2094.0
P/P	DW	1.0	438.0	98.0	
	PR	1.0	128.0	48.0	566.0

COMMENT TABLE 1

APEXED BY CE 2/22/10
 UPDATED BY CLOBERG 05/12/25

COMMENT TABLE 2

MLH 04/22/25

COMMENT TABLE 3

CLEAN UP L4

Net LIVABLE cnt 1 (rounded) 2,094

SKETCH/AREA TABLE ADDENDUM

SUBJECT INFO

File No.: 535745 Parcel No.: 092W28B 00900
 Property Address: 13105 MOUNTAIN VIEW LN SE
 City: TURNER County: State: OR ZipCode: 97392
 Owner:
 Client: Client Address:
 Appraiser Name: Inspection Date:

SKETCH

535745
092W28B 00900

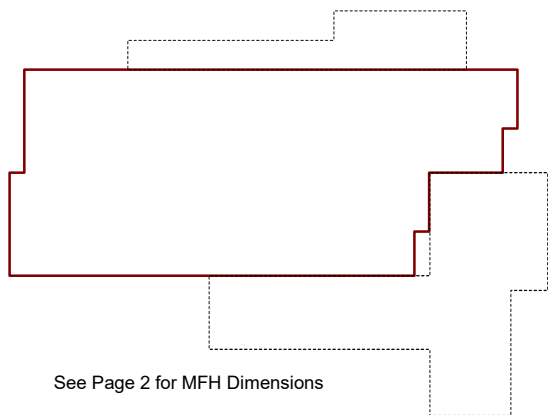
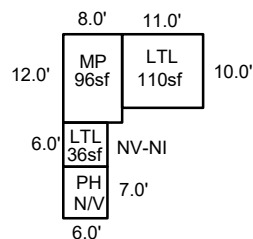
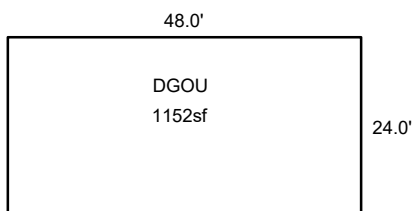

Sketch by ApexSketch

AREA CALCULATIONS SUMMARY						COMMENT TABLE 1	
Code	Description	Factor	Net Size	Perimeter	Net Totals		
GBA1	MP	1.0	96.0	40.0		APEXED BY CE 2/22/10 UPDATED BY CLOBERG 05/12/25	
	LTL	1.0	36.0	24.0	132.0		
GLA1	MFH	1.0	1712.0	194.0	1712.0		
GAR	DGOU	1.0	1152.0	144.0	1152.0		
OTH	LTL	1.0	110.0	42.0	110.0		
P/P	DF	1.0	256.0	108.0			
	DF	1.0	743.0	158.0	999.0		
						COMMENT TABLE 2	COMMENT TABLE 3
						MLH 04/22/25	CLEAN UP L4
		Net LIVABLE	cnt	0 (rounded)	1,712		
		Net BUILDING	cnt	2 (rounded)	132		

SKETCH/AREA TABLE ADDENDUM

SUBJECT INFO

File No.: 535745 Parcel No.: 092W28B 00900
 Property Address: 13105 MOUNTAIN VIEW LN SE
 City: TURNER County: State: OR ZipCode: 97392
 Owner:
 Client: Client Address:
 Appraiser Name: Inspection Date:

SKETCH

535745
092W28B 00900

See Page 1 for Outbuildings

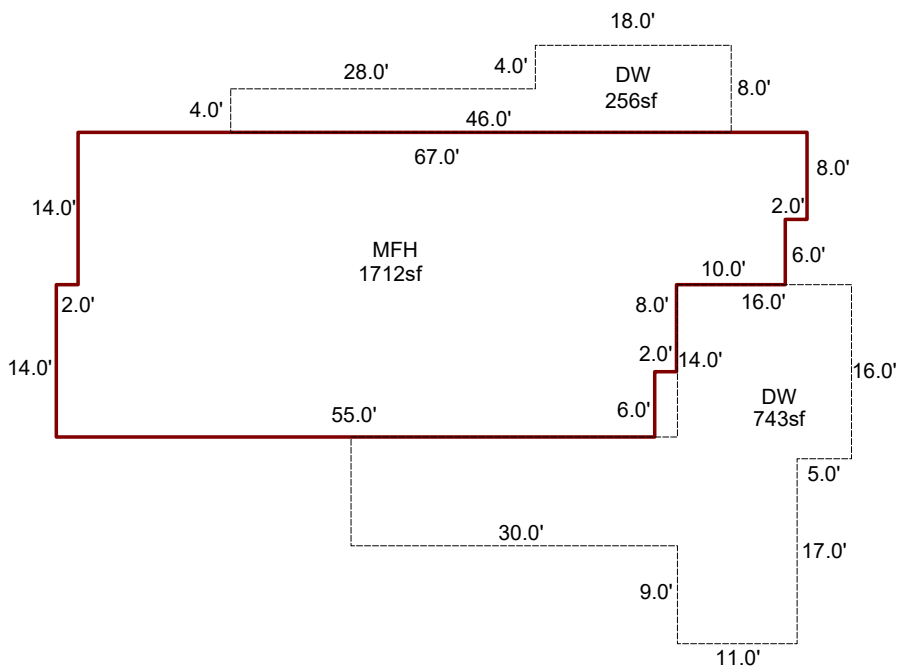

Sketch by ApexSketch

AREA CALCULATIONS SUMMARY

Code	Description	Factor	Net Size	Perimeter	Net Totals
GLA1	MFH	1.0	1712.0	194.0	1712.0
P/P	DW	1.0	256.0	108.0	
	DW	1.0	743.0	158.0	999.0

COMMENT TABLE 1

APEXED BY CE 2/22/10
 UPDATED BY CLOBERG 05/12/25

COMMENT TABLE 2

MLH 04/22/25

COMMENT TABLE 3

CLEAN UP L4

Net LIVABLE cnt 0 (rounded) 1,712

R35745
092W28B 00900

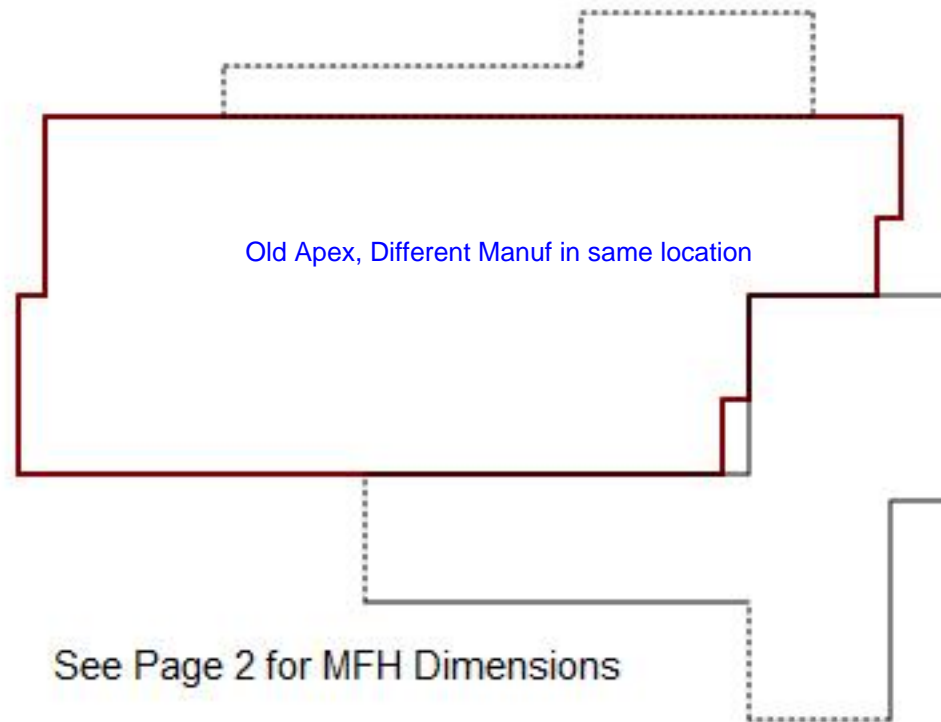
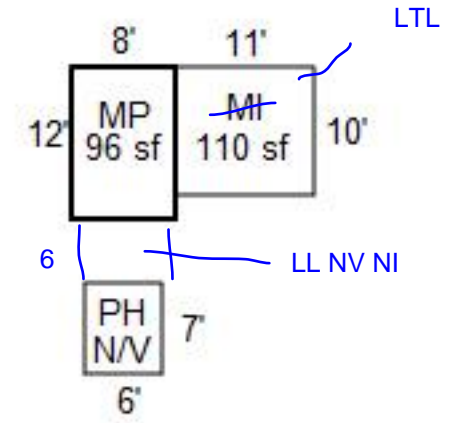
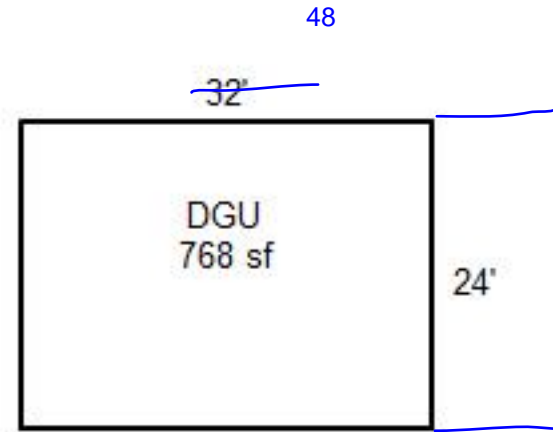

4/22/25 MLH Clean Up L4

