

Acct ID: 515728 MTL: 061W080000900 Date: S.I.25 Appr: JJS Prop Class: 559 RMV Prop Class: 559
 Situs: 11091 SARATOGA DR NE SALEM OR 97301 MaSaNh: 02 06 000 Unit: 17 Year: 2024

Last Date Appraised: 12/16/2013 Appraiser: JORDAN SCHULTZ Retag: Y N Tag info: _____

Owner: JOHNSON, RONALD W & JOHNSON, CYNTHIA H Roll Type: R

Cycle Tag Sales Verification Other: _____ Inspection level: 1 2 3 4 LCB TTO INSP AV: 177270

RMV Land: 76200 RMV Imp: 169560 RMV Total: 245760 MAV: 163410 MSAV: 13860 SAV: 20930

Comment:

Upd Inv + Apex

Notations

No notation data available.

OSDs

Count	Code	Description	RMV	Code Area	Exception
1	SAA	SA OSD - AVERAGE	45000	04470	0

Land

Site: 2 Code Area: 04470 Size: 0.90 Acres Use Code: 005 Zone: REST SAV Use: 011 Exception: 0
 Class: 2BD Value Source: Farm Homesite Description: TWO BENCH DRY RMV: 31200 Exception: Y N
 Adjustment(s): GSOIL Fire Patrol: Description:
 Comments: Liability year - 2009 / 00400158 //06-07: INCREASE HOMESITE TO ONE ACRE VALUE, ADD EXCEPTION VALUE, NO PAT LIAB WILL BE COLLECTED.

Improvements - Residence / Manufactured Structures

Bldg: 1 Code Area: 04470 Stat Class: 158 Year Blt: 1994 Eff Year Blt: 1994 Sq.Ft: 0 % Complete: 100
 Desc: Res other improvements Dimensions: RMV: 72750
 Func Obsc: 100 Econ %: 100 Other %: 100 Exception: 0 Adjust: Adjust RMV: 0

Floors

Type	Class	Display Group	Floor Size	Beds	Baths	Yr Blt	Eff Yr Blt	Inventory	Exception
Garage Detached	5	Unfinished	720	0	0	1994	1994	ROOF	Y N

Accessories

Description	Class	Size SqFt	Eff Yr Blt	RMV	Quantity
No accessory data available					

Bldg: 3 Code Area: 04470 Stat Class: 108 Year Blt: _____ Eff Year Blt: _____ Sq.Ft: _____ % Complete: 100
 Desc: Residential Other Improvements Dimensions: RMV: 0
 Func Obsc: 0 Econ %: 100 Other %: 100 Exception: 0 Adjust: Adjust RMV: 0

Floors

Type	Class	Display Group	Floor Size	Beds	Baths	Yr Blt	Eff Yr Blt	Inventory	Exception
No floor data available									

Turn into 30x20 FL 2007 NIV

Accessories

Description	Class	Size SqFt	Eff Yr Blt	RMV	Quantity
GARDEN GREENHOUSE	1	600	0	0	1

Bldg: 4 Code Area: 04470 Stat Class: 478 Year Blt: 1993 Eff Year Blt: 1993 Sq.Ft: 2406 % Complete: 100
 Desc: MANUF STRUCT, CLASS 7, 36' WIDE TRIPLE/QUAD Dimensions: RMV: 78810
 Func Obsc: 100 Econ %: 100 Other %: 100 Exception: 0 Adjust: Adjust RMV: 0

Floors

Type	Class	Display Group	Floor Size	Beds	Baths	Yr Blt	Eff Yr Blt	Inventory	Exception
First Floor	7	Finished	2440	3	FB-2	1993	1993	SKRT+, ROOF, HVAC+, KIT-, BATH - 2	Y N

Accessories

Description	Class	Size SqFt	Eff Yr Blt	RMV	Quantity
No accessory data available					

Bldg: 5 Code Area: 04470 Stat Class: 108 Year Blt: 1963 Eff Year Blt: 1963 Sq.Ft: 0 % Complete: 100
 Desc: Residential Other Improvements Dimensions: RMV: 7700
 Func Obsc: 100 Econ %: 100 Other %: 100 Exception: 0 Adjust: Adjust RMV: 0

Floors

Type	Class	Display Group	Floor Size	Beds	Baths	Yr Blt	Eff Yr Blt	Inventory	Exception
No floor data available									

Accessories

Description	Class	Size SqFt	Eff Yr Blt	RMV	Quantity	
DECK	1	542	1963	7696	1	Exception: Y N

Improvements - Accessory Buildings

Bldg: 2 Code Area: 04470 Stat Class: 312 Year Blt: 1974 Eff Year Blt: 1974 Sq.Ft: 1760 % Complete: 100
Desc: Loft Barn (LB) Dimensions: 44x40 RMV: 8250
Func Obsc: 100 Econ %: 100 Other %: 100 Exception: 0 Adjust: Adjust RMV: 0

Floors

Type	Class	Display Group	Floor Size	Beds	Baths	Yr Blt	Eff Yr Blt	Inventory	
Loft Barn	4	Finished	1760	0	0	1974	1974	F	Exception: Y N

Accessories

Description	Class	Size SqFt	Eff Yr Blt	RMV	Quantity
No accessory data available					

Bldg: 6 Code Area: 04470 Stat Class: 341 Year Blt: 1996 Eff Year Blt: 1996 Sq.Ft: 192 % Complete: 100
Desc: Multi Purpose Shed (MP) Dimensions: 16x12 RMV: 2050
Func Obsc: 100 Econ %: 100 Other %: 100 Exception: 0 Adjust: Adjust RMV: 0

Floors

Type	Class	Display Group	Floor Size	Beds	Baths	Yr Blt	Eff Yr Blt	Inventory	
Multi-Purpose Bldg	5	Finished	192	0	0	1996	1996	F	Exception: Y N

Accessories

Description	Class	Size SqFt	Eff Yr Blt	RMV	Quantity
No accessory data available					

SKETCH/AREA TABLE ADDENDUM

SUBJECT INFO

File No.: 515728 Parcel No.: 061W080000900
 Property Address: 11091 SARATOGA DR NE
 City: SALEM County: State: OR ZipCode: 97305
 Owner:
 Client: Client Address:
 Appraiser Name: Inspection Date:

SKETCH

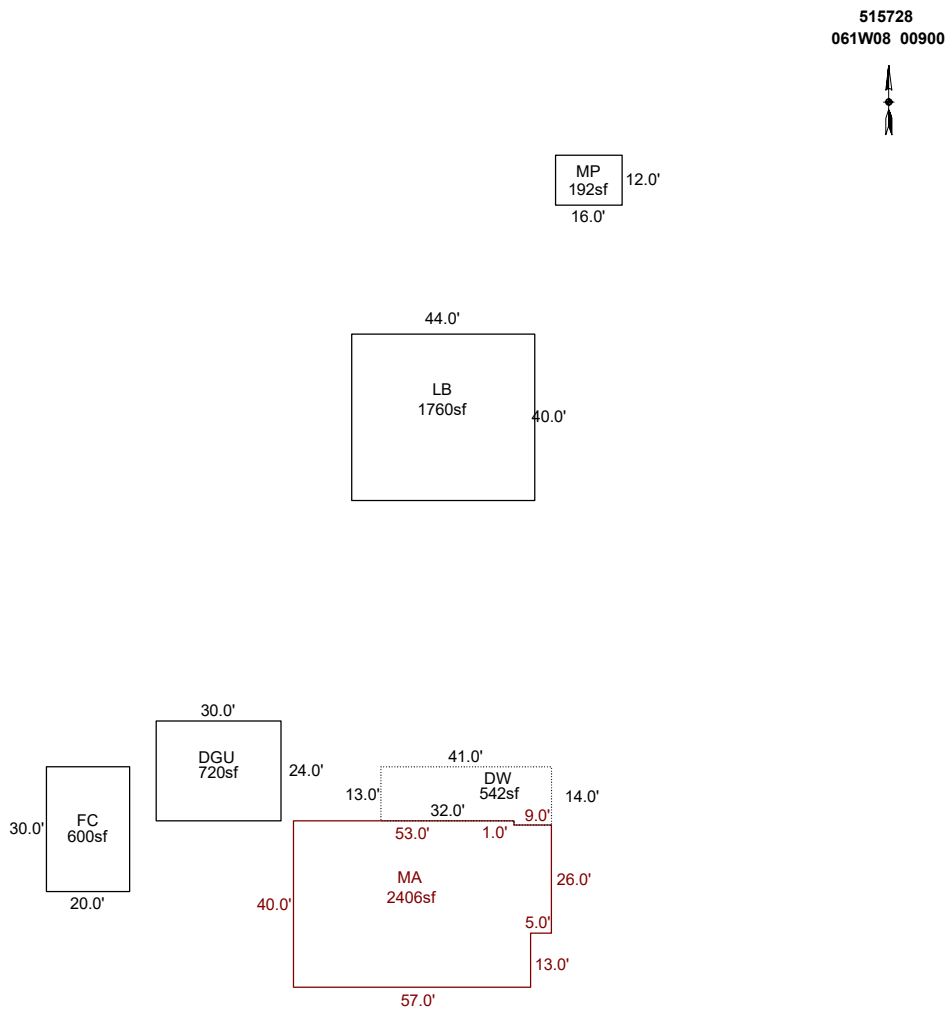

AREA CALCULATIONS SUMMARY

Code	Description	Factor	Net Size	Perimeter	Net Totals
GBA1	LB	1.0	1760.0	168.0	
	MP	1.0	192.0	56.0	
	FC	1.0	600.0	100.0	2552.0
DGF	DGU	1.0	720.0	108.0	720.0
OTH	MA	1.0	2406.0	204.0	2406.0
P/P	DW	1.0	542.0	110.0	542.0

COMMENT TABLE 1

DRAWN BY SH 9-11-12
 Update to add YI's, MP and DGF 2/20/13 Jane
 Updated by CW 1/24/14
 UPDATED BY CLOBERG 05/12/25

COMMENT TABLE 2

JIS 05/01/25

COMMENT TABLE 3

CYCLE L3

Net BUILDING cnt 3 (rounded) 2,552

SKETCH/AREA TABLE ADDENDUM

Parcel No 061W08 00900

File No R15728

SUBJECT

Property Address 11091 SARATOGA DR NE

City SALEM

State OR

Zip 97305

Owner

Client

Appraiser Name

IMPROVEMENTS SKETCH

R15728
061W08 00900

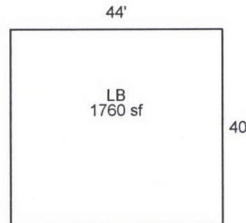
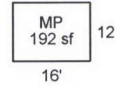
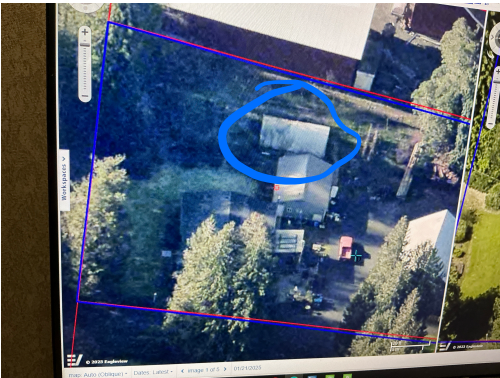

20
30
FL

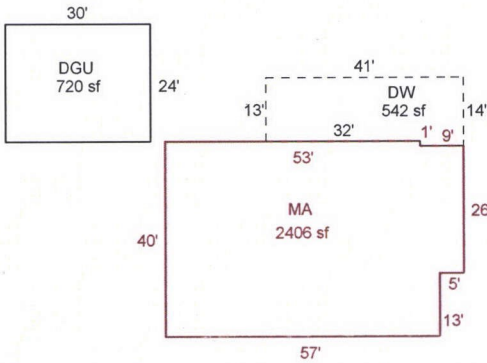

Scale: 1 = 40

AREA CALCULATIONS

AREA CALCULATIONS SUMMARY

Code	Description	Factor	Net Size	Perimeter	Net Totals
GBA1	LB	1.00	1760	168	
	MP	1.00	192	56	1952
DGF	DGU	1.00	720	108	720
P/P	DW	1.00	542	110	542
OTH	MA	1.00	2406	204	2406

Comment Table 1

DRAWN BY SH 9-11-12
Update to add YI's, MP and DGF 2/20/13 Jane
Updated by CW 1/24/14

Comment Table 2

JJS S.I.2S

Comment Table 3

cycle L3

Net BUILDING Area (rounded w/ factors)

1952