

Acct ID: 530795 MTL: 082W28B000500 Date: 2/27/25 Appr: MDL Prop Class: 641 RMV Prop Class: 401
 Situs: 7079 COMBEST LN SE TURNER OR 97392 MaSaNh: 07 06 000 Unit: 75569 Year: 2025

Last Date Appraised: 06/16/2023 Appraiser: MATT LORD Retag: Y (N) Tag info:
 Owner: MCMILLAN, CLINTON Roll Type: R
 Cycle Tag Sales Verification Other: _____ Inspection level: 1 2 3 4 LCB TTO INSP (30) AV: 257495
 RMV Land: 285220 RMV Imp: 536600 RMV Total: 821820 MAV: 256350 MSAV: 1145 SAV: 2081
 Comment: 24-25: L4 06.16.23 MDL
 MLS 818923
 DOM 09

Notations 25-26: SV

FOREST OK

RP/MS	Code	Description
RP	DFL	DESIGNATED FORESTLAND

OSDs

Count	Code	Description	RMV	Code Area	Exception
1	MKTA	OSD - AVERAGE	50000	05590	0

Land

Site: 1 Code Area: 05590 Size: 0.54 Acres Use Code: 005 Zone: REST SAV Use: Exception: 0
 Class: 4BD Value Source: Market Homesite Description: FOUR BENCH DRY RMV: 50010 Exception: Y N

Adjustment(s): Fire Patrol: Description:

Comments: 16-17: PER #36 ROLL 2.0 ACRES FROM FARM (0.54 OF WHICH IS SA HOMESITE) TO DFL. DISQ HOMESITE AND OSD AS < 10 ACRES// 99-2000: DISQ FARM USE / 2000-2001; MARKET LAND VALUES UPDATED . FARM USE APPROVED / 02-03: REAPP

Site: 3 Code Area: 05590 Size: 1.54 Acres Use Code: 005 Zone: REST SAV Use: 011 Exception: 0
 Class: FTLC Value Source: Designated Forest Land Description: DFL Class C RMV: 142610 Exception: Y N

Adjustment(s): Fire Patrol: Description:

Comments: Liability year - 2000 / 00-01: 00500190, FARM USE APPROVED /01-02; CHANGED SOIL CLASS FROM 3 HILL DRY TO 4 HILL DRY

Site: 4 Code Area: 05590 Size: 0.46 Acres Use Code: 005 Zone: REST SAV Use: 011 Exception: 0
 Class: FTLC Value Source: Designated Forest Land Description: DFL Class C RMV: 42600 Exception: Y N

Adjustment(s): Fire Patrol: Description:

Comments: Liability year - 2009

Improvements - Residence / Manufactured Structures

Bldg: 1 Code Area: 05590 Stat Class: 142 Year Blt: 1958 Eff Year Blt: 2001 Sq.Ft: 3803 % Complete: 100
 Desc: Multi Story above grade Dimensions: RMV: 535290
 Func Obsc: 100 Econ %: 100 Other %: 100 Exception: 0 Adjust: Adjust RMV: 0

Floors

Type	Class	Display Group	Floor Size	Beds	Baths	Yr Blt	Eff Yr Blt	Inventory	Exception
First Floor	4	Finished	2322	3	FB-2	1958	2001	FP - 1, HVAC, ROOF, KIT-, BATH - 2	Y N
Attic	4	Finished	1481	0	0	1958	2001	HVAC	Y N
Garage Attached	4	Unfinished	936	0	0	1975	1975 2001	ROOF	Y N

Accessories

Description	Class	Size SqFt	Eff Yr Blt	RMV	Quantity	Exception
YARD IMPROVEMENTS AVERAGE ✓	4	0	2001	28569	1	Y N

Improvements - Accessory Buildings

Bldg: 2 Code Area: 05590 Stat Class: 341 Year Blt: 1964 Eff Year Blt: 1964 Sq.Ft: 416 % Complete: 100
 Desc: Multi Purpose Shed (MP) Dimensions: 26x16 RMV: 1310
 Func Obsc: 100 Econ %: 100 Other %: 100 Exception: 0 Adjust: Adjust RMV: 0

Floors

Type	Class	Display Group	Floor Size	Beds	Baths	Yr Blt	Eff Yr Blt	Inventory	Exception
Multi-Purpose Bldg	4	Finished	416	0	0	1964	1964	<u>FAIR</u>	Y N

Accessories

Description	Class	Size SqFt	Eff Yr Blt	RMV	Quantity
No accessory data available					

SKETCH/AREA TABLE ADDENDUM

SUBJECT INFO

File No.: 530795 Parcel No.: 082W28B 00500
 Property Address: 7079 COMBEST LN SE
 City: TURNER County: MARION State: OR ZipCode: 97392
 Owner:
 Client:
 Client Address:
 Appraiser Name: Inspection Date:

SKETCH

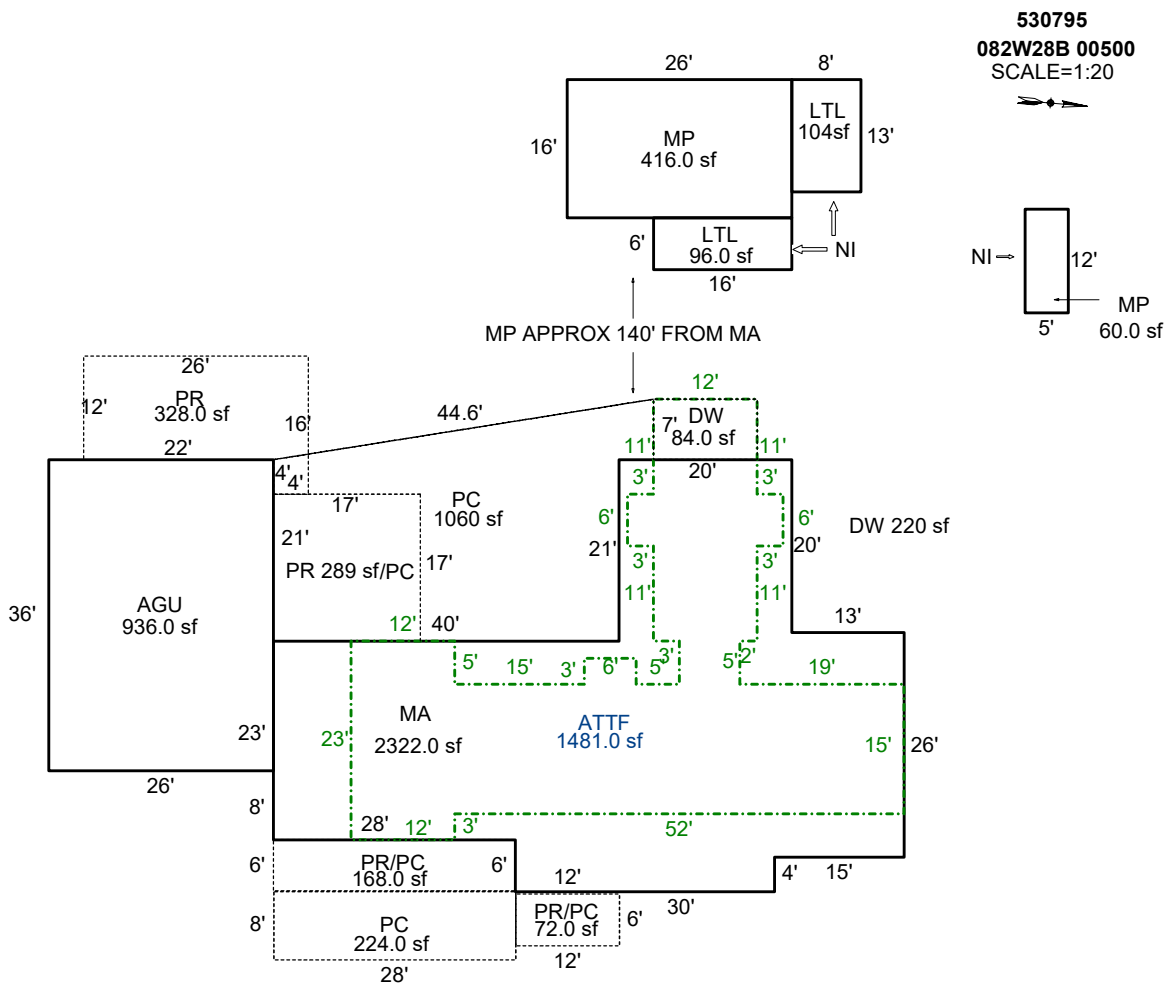

Sketch by ApexSketch

AREA CALCULATIONS SUMMARY						COMMENT TABLE 1					
Code	Description	Factor	Net Size	Perimeter	Net Totals						
GBA1	MP	1.0	416.0	84.0		DRAWN BY JRONDEMA 6/8/15 UPDATED BY PH 8/1/19 UPDATED BY CLOBERG 05/16/25					
	LTL	1.0	104.0	42.0							
	LTL	1.0	96.0	44.0							
	MP	1.0	60.0	34.0	676.0						
	GLA1	MA	1.0	2322.0	246.0			2322.0			
	GLA2	ATTF	1.0	1481.0	268.0			1481.0			
	GAR	AGU	1.0	936.0	124.0			936.0			
YI	PC	1.0	0.0	89.1		<table border="1" style="width: 100%; border-collapse: collapse;"> <thead> <tr> <th style="text-align: left;">COMMENT TABLE 2</th> <th style="text-align: left;">COMMENT TABLE 3</th> </tr> </thead> <tbody> <tr> <td>5/7/15 #94 CYCLE, N.V. 6/21/19 SR #94, FOREST MDL 02/27/25</td> <td>SV L4</td> </tr> </tbody> </table>		COMMENT TABLE 2	COMMENT TABLE 3	5/7/15 #94 CYCLE, N.V. 6/21/19 SR #94, FOREST MDL 02/27/25	SV L4
	COMMENT TABLE 2	COMMENT TABLE 3									
	5/7/15 #94 CYCLE, N.V. 6/21/19 SR #94, FOREST MDL 02/27/25	SV L4									
	PR/PC	1.0	168.0	68.0							
	PC	1.0	224.0	72.0							
	PR/PC	1.0	72.0	36.0							
	PR	1.0	328.0	84.0							
DW	1.0	84.0	38.0	876.0							
	Net LIVABLE	cnt	0 (rounded)		3,803						
	Net BUILDING	cnt	4 (rounded)		676						

