

Acct ID: 528079 MTL: 081W040000500 Date: 6/4/25 Appr: CWO Prop Class: 551 RMV Prop Class: 501
 Situs: 2220 119TH AVE SE SALEM OR 97317 MaSaNh: 01 06 000 Unit: 22846 Year: 2025

Last Date Appraised: 09/30/2024 Appraiser: CLINT LUKE Retag: Y (N) Tag info: 2025 - Tags/Permit (Completion)
 Owner: CONDIT LT occupant of travel trailer Roll Type: R
 Cycle Tag Sales Verification Other: FF Check Inspection level: 1 (2) 3 4 (LCB) TTO INSP AV: 385143
 RMV Land: 630830 RMV Imp: 410040 RMV Total: 1040870 MAV: 287560 MSAV: 37183 SAV: 64305

Comment: 25-26 L4 9/30/24 CLUKE
 24-25 L4 8/14/24 CLUKE
 23-24: L2 2-9-23 CL
 22-23 L2 12/22/21 CL/
 LEVEL 2 3.29.21 CL10//

Jared 503-931-7226

CWO Input 6/5/25

1/22/24: CWO spoke to Jared and explained the reason for the inquiry letter. He plans to convert it into pastureland for livestock. Check status 5/1/25.

24-25: Per CWO inspected 1/4/24 L4 and MDL observed during tag that approximately 7.5 acres of woodlot has been cleared. Send inquiry letter.

Notations

RP/MS	Code	Description
RP	ZONED	FARM EFU ZONED

No fencing or animals seen where woodlot used to be. Send intent letter.

OSDs

Count	Code	Description	RMV	Code Area	Exception
1	SAA	SA OSD - AVERAGE	50000	04500	0

Land

Site: 1 Code Area: 04500 Size: 1.00 Acres Use Code: 005 Zone: REST SAV Use: 011 Exception: 0
 Class: 4HD Value Source: Farm Homesite Description: FOUR HILL DRY RMV: 19560 Exception: Y N
 Adjustment(s): Fire Patrol: Description:
 Comments: Liability year - 2009

25-26 SOIL VERIFIED

Site: 2 Code Area: 04500 Size: 15.40 Acres Use Code: 005 Zone: REST SAV Use: 011 Exception: 0
 Class: 4HD Value Source: Farm Use - EFU Description: FOUR HILL DRY RMV: 301170 Exception: Y N
 Adjustment(s): Fire Patrol: Description:
 Comments: Liability year - 1974 / 04200028 /01-02; CHANGED SOIL CLASS FROM 3 HILL DRY TO 4 HILL DRY //05-06 #10 CHG OF 2 HILL TO 4HILL.

Site: 3 Code Area: 04500 Size: 13.30 Acres Use Code: 005 Zone: REST SAV Use: 011 Exception: 0
 Class: 4HD Value Source: Woodlot Description: FOUR HILL DRY RMV: 260100 Exception: Y N
 Adjustment(s): Fire Patrol: Description:
 Comments: Liability year - 1974 //08-09: Market woodlot study by GW39 - change from woodlot to woodlot-M// 04200028 //05-06: #10 CHG OF SOIL CLASS FROM 2HILL TO WOODLOT.

Improvements - Residence / Manufactured Structures

Bldg: 1 Code Area: 04500 Stat Class: 141 Year Blt: 1971 Eff Year Blt: 1980 Sq.Ft: 2950 % Complete: 100
 Desc: One Story Only Dimensions: RMV: 394070
 Func Obsc: 100 Econ %: 100 Other %: 100 Exception: 60400 Adjust: Adjust RMV: 0

Floors

Type	Class	Display Group	Floor Size	Beds	Baths	Yr Blt	Eff Yr Blt	Inventory	Exception
First Floor	4	Finished	2950	4	FB-3	1971	1980	BATH - 3, KIT, HVAC, FP - 1, ROOF	Y N
Garage Attached	4	Finished	529	0	0	1971	1971	ROOF	Y N

Accessories

Description	Class	Size SqFt	Eff Yr Blt	RMV	Quantity
YARD IMPROVEMENTS AVERAGE	4	0	1980	25038	1

Exception: Y N

Improvements - Accessory Buildings

Bldg: 2 Code Area: 04500 Stat Class: 351 Year Blt: 1988 Eff Year Blt: 2003 Sq.Ft: 1296 % Complete: 100
 Desc: General Purpose Building (GB) Dimensions: 36x36 RMV: 11500
 Func Obsc: 100 Econ %: 100 Other %: 100 Exception: 0 Adjust: Adjust RMV: 0

Floors

Type	Class	Display Group	Floor Size	Beds	Baths	Yr Blt	Eff Yr Blt	Inventory	Exception
General Purpose Bldg	4	Finished	1296	0	0	1988	2003	FAIR	Y N

Accessories

Description	Class	Size SqFt	Eff Yr Blt	RMV	Quantity
No accessory data available					

Bldg: 3 Code Area: 04500 Stat Class: 353 Year Blt: 2010 Eff Year Blt: 2010 Sq.Ft: 288 % Complete: 100
 Desc: Machine Shed (MS) Dimensions: 36x8 RMV: 2700

Func Obsc: 100

Econ %: 100

Other %: 100

Exception: 0

Adjust:

Adjust RMV: 0

Floors

Type	Class	Display Group	✓ Floor Size	Beds	Baths	Yr Blt	Eff Yr Blt	Inventory	Exception: Y N
Machine Shed	4	Finished	288	0	0	2010	2010	FAIR	

Accessories

Description	Class	Size SqFt	Eff Yr Blt	RMV	Quantity
No accessory data available					

Bldg: 4 Code Area: 04500 Stat Class: 321 Year Blt: Eff Year Blt: 2010 Sq.Ft: 240 % Complete: 100

Desc: Hay Cover (HC)

Dimensions: 20x12 RMV: 1770

Func Obsc: 100

Econ %: 100

Other %: 100

Exception: 0

Adjust:

Adjust RMV: 0

Floors

Type	Class	Display Group	✓ Floor Size	Beds	Baths	Yr Blt	Eff Yr Blt	Inventory	Exception: Y N
Hay Cover	5	Finished	240	0	0	0	2010	AVG	

Accessories

Description	Class	Size SqFt	Eff Yr Blt	RMV	Quantity
No accessory data available					



Left side of Driveway



Right side no fencing or animals

SKETCH/AREA TABLE ADDENDUM

SUBJECT INFO

File No.: 528079 Parcel No.: 081W04 00500
 Property Address: 2220 119TH AVE SE
 City: Salem County: Marion State: OR ZipCode: 97317
 Owner:
 Client: Client Address:
 Appraiser Name: Inspection Date:

SKETCH

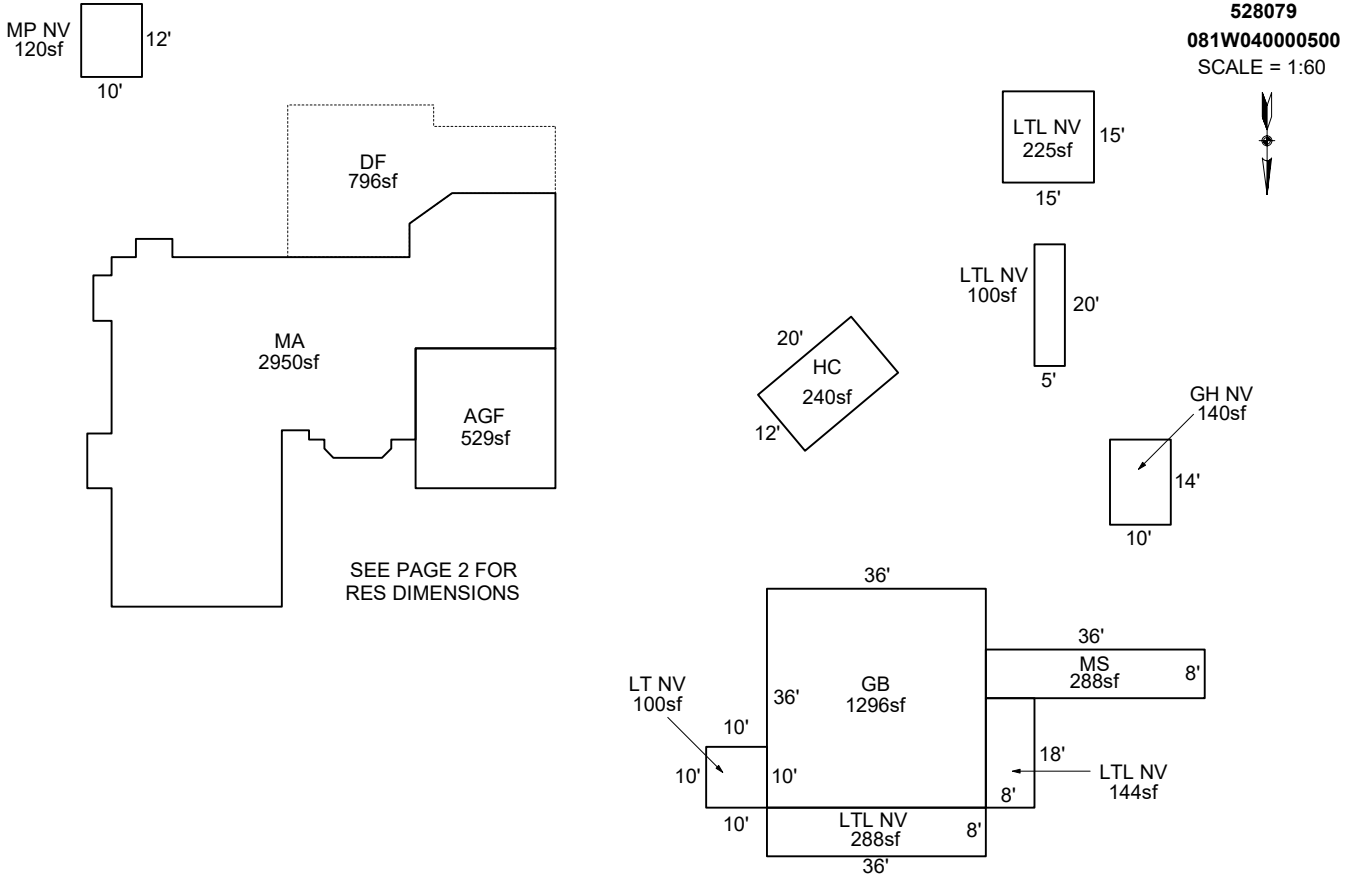

Sketch by ApexSketch

AREA CALCULATIONS SUMMARY

Code	Description	Factor	Net Size	Perimeter	Net Totals
GBA1	MP NV	1.0	120.0	44.0	
	GB	1.0	1296.0	144.0	
	MS	1.0	288.0	88.0	
	GH NV	1.0	140.0	48.0	
	HC	1.0	240.0	64.0	
	LTL NV	1.0	100.0	50.0	
	LTL NV	1.0	225.0	60.0	
	LTL NV	1.0	144.0	52.0	
	LTL NV	1.0	288.0	88.0	
	LT NV	1.0	100.0	40.0	2941.0
GLA1	MA	1.0	2950.0	305.8	2950.0
GAR	AGF	1.0	529.0	92.0	529.0
P/P	DF	1.0	795.5	134.6	795.5
	Net LIVABLE	cnt	1 (rounded)		2,950
	Net BUILDING	cnt	10 (rounded)		2,941

COMMENT TABLE 1

APEX BY CJURAN 11/13/2023
 UPDATED BY CLOBERG 10/29/24

COMMENT TABLE 2

CL 3/29/2021
 CL 12/22/2021
 CL 02/09/2023
 MDL 10/30/2023
 CLUKE 09/30/24

COMMENT TABLE 3

L2
 22-23 L2
 23-24 L2
 24-25 L4
 TAGS L4