

SKETCH/AREA TABLE ADDENDUM

SUBJECT INFO

File No.: 333497 Parcel No.: 063W34CB00600
 Property Address: 1277 TRENT AV N
 City: KEIZER County: Marion State: OR ZipCode: 97303
 Owner:
 Client: Client Address:
 Appraiser Name: Inspection Date:

SKETCH

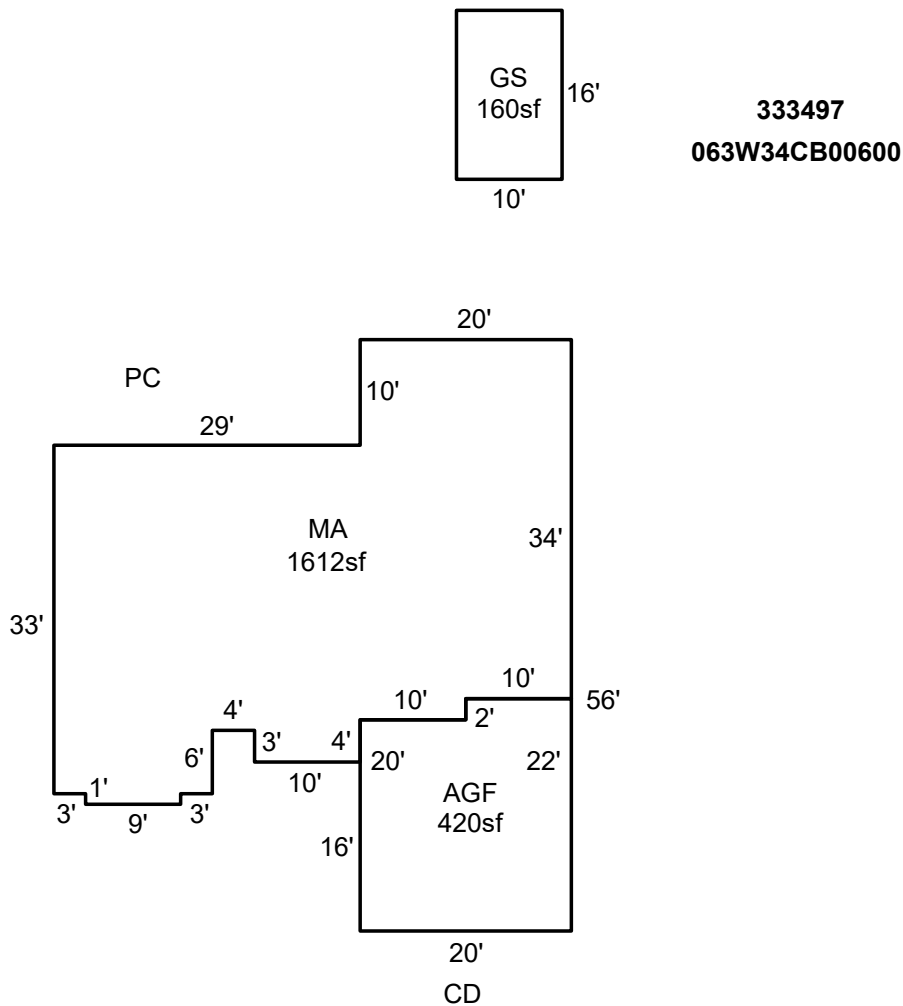

Sketch by ApexSketch

AREA CALCULATIONS SUMMARY

Code	Description	Factor	Net Size	Perimeter	Net Totals
GBA	GS	1.0	160.0	52.0	160.0
GLA	MA	1.0	1612.0	192.0	1612.0
GAR	AGF	1.0	420.0	84.0	420.0

COMMENT TABLE 1

APEX BY MJB 05-02-11
 Updated by AE 7.9.25

COMMENT TABLE 2

6/7/18 101 Cycle NV

COMMENT TABLE 3

Net LIVABLE	cnt	1	(rounded)		1,612
Net BUILDING	cnt	1	(rounded)		160