

# SKETCH/AREA TABLE ADDENDUM

## SUBJECT INFO

File No.: 330767 Parcel No.: 093W35CD01200  
 Property Address: 14971 LAUREL LN SE  
 City: JEFFERSON County: Marion State: OR ZipCode:  
 Owner:  
 Client: Client Address:  
 Appraiser Name: Inspection Date:

## SKETCH

330767  
093W35CD01200  
SCALE 1:30

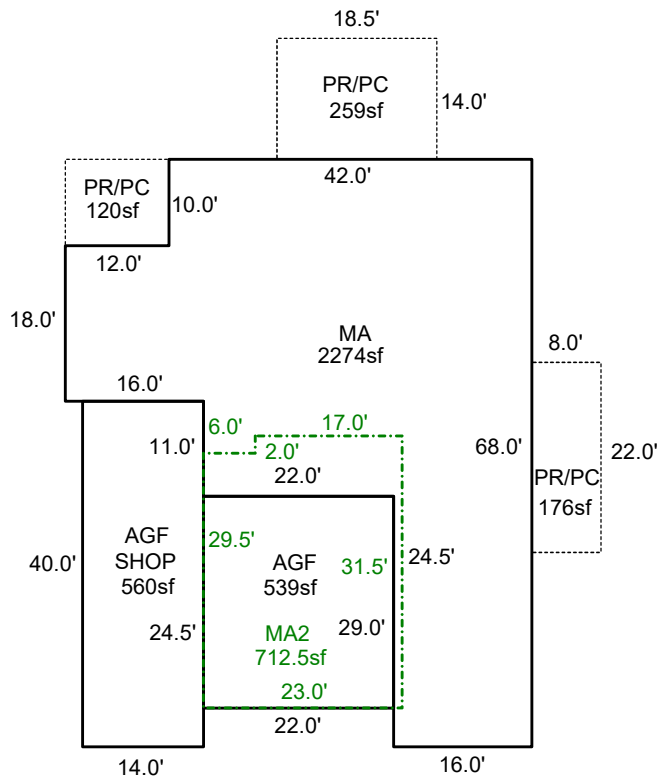

Sketch by ApexSketch

AREA CALCULATIONS SUMMARY						COMMENT TABLE 1		
Code	Description	Factor	Net Size	Perimeter	Net Totals			
MA2	MA2	1.0	712.5	109.0	712.5	APEX BY CLOBERG 08/06/25 25-004093 MA		
GAR	AGF	1.0	560.0	108.0				
	AGF	1.0	539.0	93.0	1099.0			
MA	MA	1.0	2274.0	244.0	2274.0			
P/P	PR/PC	1.0	176.0	60.0				
	PR/PC	1.0	259.0	65.0				
	PR/PC	1.0	120.0	44.0	555.0			
						<b>COMMENT TABLE 2</b>	<b>COMMENT TABLE 3</b>	
Net LIVABLE						cnt	2 (rounded)	2,987