

Acct ID: 536349 MTL: 093W160000500 Date: **6/6/25** Appr: **MLH** Prop Class: 451 RMV Prop Class: 451  
 Situs: 318 ANKENY HILL RD SE JEFFERSON OR 97352 MaSaNh: 07 06 000 Unit: 34570 Year: 2025

Last Date Appraised: 08/31/2018 Appraiser: MATT LORD Retag: Y N Tag info:  
 Owner: OLIVA, ADRIAN & OLIVA, MARIA Roll Type: R  
 Cycle Tag Sales Verification Other: **Clean Up** Inspection level: 1 2 3 **4** LCB TTO INSP AV: 535310  
 RMV Land: 331220 RMV Imp: 741190 RMV Total: 1072410 MAV: 535310 MSAV: 0 SAV: 0  
 Comment:

*update Inventory*

**Input MLH 7/11/25**

**Notations**

RP/MS	Code	Description
MS	PERM	PERMANENTLY DISQUALIFIED FROM FARM/FOREST

**OSDs**

Count	Code	Description	RMV	Code Area	Exception
1	MKTG	OSD - GOOD <i>Ave</i>	60000	14530	0

**Land**

Site: 1 Code Area: 14530 Size: 3.12 Acres Use Code: 005 Zone: REST SAV Use: Exception: 0  
 Class: 2BDS Value Source: Permanently Disqualified Description: TWO BENCH DRY SOUTH SPECIAL RMV: 271220 Exception: Y N  
 S  
 Adjustment(s): GSOIL Fire Patrol: Description:  
 Comments: 2003-04 REAPPRAISAL.

**Improvements - Residence / Manufactured Structures**

Bldg: 1 Code Area: 14530 Stat Class: 152 Year Blt: 1999 Eff Year Blt: 1999 Sq.Ft: 3942 % Complete: 100  
 Desc: Multi Story above grade Dimensions: RMV: 655310  
 Func Obsc: 100 Econ %: 100 Other %: 100 Exception: 0 Adjust: Adjust RMV: 0 *I/0*

**Floors**

Type	Class	Display Group	Floor Size	Beds	Baths	Yr Blt	Eff Yr Blt	Inventory	Exception
First Floor	5	Finished	2153	2	FB-2	1999	1999	BATH - 2, KIT-, ROOF, HVAC+, FP - 1	Y N
Second Floor	5	Finished	1589	3	FB-3	1999	1999	BATH - 3, BATH+, HVAC+	Y N
Attic	5	Finished	200	0	0	1999	1999	<i>HVAC +</i>	Y N

**Accessories**

Description	Class	Size SqFt	Eff Yr Blt	RMV	Quantity	Exception
CONCRETE DRIVEWAY <i>part of YI</i>	5	3203	1999	9160	1	Y N

Bldg: 5 Code Area: 14530 Stat Class: 107 Year Blt: Eff Year Blt: 1999 Sq.Ft: 0 % Complete: 100  
 Desc: Yard Improvements Dimensions: RMV: 29440  
 Func Obsc: 100 Econ %: 100 Other %: 100 Exception: 0 Adjust: Adjust RMV: 0

**Floors**

Type	Class	Display Group	Floor Size	Beds	Baths	Yr Blt	Eff Yr Blt	Inventory	Exception
No floor data available									

**Accessories**

Description	Class	Size SqFt	Eff Yr Blt	RMV	Quantity	Exception
YARD IMPROVEMENTS FAIR	5	1	1999	29436	1	Y N

**Improvements - Accessory Buildings**

Bldg: 2 Code Area: 14530 Stat Class: 351 Year Blt: 2000 Eff Year Blt: *2000* Sq.Ft: 884 % Complete: 100  
 Desc: General Purpose Building (GB) Dimensions: 34x26 RMV: 10580  
 Func Obsc: 100 Econ %: 100 Other %: 100 Exception: 0 Adjust: Adjust RMV: 0 *I/0*

**Floors**

Type	Class	Display Group	Floor Size	Beds	Baths	Yr Blt	Eff Yr Blt	Inventory	Exception
General Purpose Bldg	5	Finished	884	0	0	2000	2000	<i>FAIR Ave</i>	Y N

**Accessories**

Description	Class	Size SqFt	Eff Yr Blt	RMV	Quantity	Exception
No accessory data available						

Bldg: 3 Code Area: 14530 Stat Class: 301 Year Blt: Eff Year Blt: Sq.Ft: 0 % Complete: 100  
 Desc: Accessory Improvements & Misc. Dimensions: RMV: 8000

Func Obsc: 100 Econ %: 100 Other %: 100 Exception: 0 Adjust: Adjust RMV: 0

*gate part of YI MOVE MAU*

Floors	Type	Class	Display Group	Floor Size	Beds	Baths	Yr Blt	Eff Yr Blt	Inventory	Exception: Y N
Building Structure	0	Finished	0	0	0	0	0	0		Exception: Y N

**Accessories**

Description	Class	Size SqFt	Eff Yr Blt	RMV	Quantity
No accessory data available					

Bldg: 4 Code Area: 14530 Stat Class: 351 Year Blt: 2008 Eff Year Blt: <sup>2010</sup>2008 Sq.Ft: 1224 % Complete: 100  
 Desc: General Purpose Building (GB) Dimensions: 36x34 RMV: 10480  
 Func Obsc: 100 Econ %: 100 Other %: 100 Exception: 0 Adjust: Adjust RMV: 0

**Floors**

Type	Class	Display Group	Floor Size	Beds	Baths	Yr Blt	Eff Yr Blt	Inventory	Exception: Y N
General Purpose Bldg	4	Finished	1224	0	0	2008	2008	<i>Ack</i>	Exception: Y N

**Accessories**

Description	Class	Size SqFt	Eff Yr Blt	RMV	Quantity
No accessory data available					

Bldg: 6 Code Area: 14530 Stat Class: 355 Year Blt: 2014 Eff Year Blt: <sup>2010</sup>2014 Sq.Ft: 680 % Complete: 100  
 Desc: Lean-to Heavy (LTH) Dimensions: 34x20 RMV: 3670  
 Func Obsc: 100 Econ %: 100 Other %: 100 Exception: 0 Adjust: Adjust RMV: 0

**Floors**

Type	Class	Display Group	Floor Size	Beds	Baths	Yr Blt	Eff Yr Blt	Inventory	Exception: Y N
Lean-to Heavy Duty	4	Finished	680	0	0	2014	2014		Exception: Y N

**Accessories**

Description	Class	Size SqFt	Eff Yr Blt	RMV	Quantity
No accessory data available					

Bldg: 7 Code Area: 14530 Stat Class: 351 Year Blt: 2010 Eff Year Blt: 2010 Sq.Ft: 700 % Complete: 100  
 Desc: General Purpose Building (GB) Dimensions: 28x25 RMV: 6840  
 Func Obsc: 100 Econ %: 100 Other %: 100 Exception: 0 Adjust: Adjust RMV: 0

**Floors**

Type	Class	Display Group	Floor Size	Beds	Baths	Yr Blt	Eff Yr Blt	Inventory	Exception: Y N
General Purpose Bldg	4	Finished	700	0	0	2010	2010	<i>Fair</i>	Exception: Y N

**Accessories**

Description	Class	Size SqFt	Eff Yr Blt	RMV	Quantity
No accessory data available					

Bldg: 8 Code Area: 14530 Stat Class: 341 Year Blt: 2002 Eff Year Blt: 2002 Sq.Ft: 216 % Complete: 100  
 Desc: Multi Purpose Shed (MP) Dimensions: 18x12 RMV: 2260  
 Func Obsc: 100 Econ %: 100 Other %: 100 Exception: 0 Adjust: Adjust RMV: 0

**Floors**

Type	Class	Display Group	Floor Size	Beds	Baths	Yr Blt	Eff Yr Blt	Inventory	Exception: Y N
Multi-Purpose Bldg	4	Finished	216	0	0	2002	2002	<i>Fair</i>	Exception: Y N

**Accessories**

Description	Class	Size SqFt	Eff Yr Blt	RMV	Quantity
No accessory data available					

Bldg: 9 Code Area: 14530 Stat Class: 355 Year Blt: 2015 Eff Year Blt: <sup>2010</sup>2015 Sq.Ft: 2640 % Complete: 100  
 Desc: Lean-to Heavy (LTH) Dimensions: <sup>33x80</sup> RMV: 14610  
 Func Obsc: 100 Econ %: 100 Other %: 100 Exception: 0 Adjust: Adjust RMV: 0

**Floors**

Type	Class	Display Group	Floor Size	Beds	Baths	Yr Blt	Eff Yr Blt	Inventory	Exception: Y N
Lean-to Heavy Duty	4	Finished	2640	0	0	2015	2015		Exception: Y N

**Accessories**

Description	Class	Size SqFt	Eff Yr Blt	RMV	Quantity
No accessory data available					

*351 GB Y 24x24 2021 Fair NEW*

# SKETCH/AREA TABLE ADDENDUM

## SUBJECT INFO

File No.: 536349 Parcel No.: 093W16 00500  
 Property Address: 318 ANKENY HILL RD SE  
 City: JEFFERSON County: State: OR ZipCode: 97352  
 Owner:  
 Client Address:  
 Appraiser Name: Inspection Date:

## SKETCH

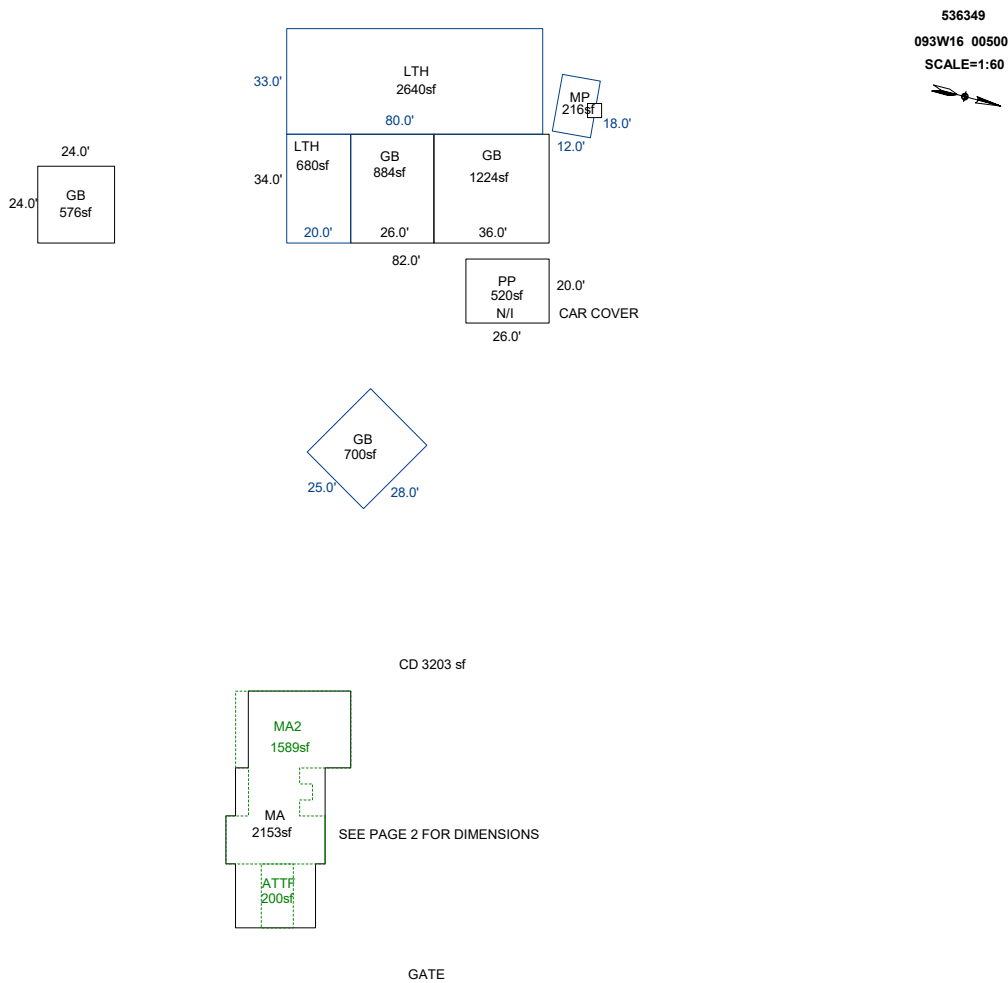

AREA CALCULATIONS SUMMARY						COMMENT TABLE 1	
Code	Description	Factor	Net Size	Perimeter	Net Totals		
GBA1	LTH	1.0	680.0	108.0		Apex by JA 8/20/09 EDITED BY NRC 08/27/2009 UPDATED BY JRONDEMA 9/13/18 UPDATED BY JRONDEMA 10/16/18 UPDATED BY CLOBERG 07/11/25	
	LTH	1.0	2640.0	226.0			
	MP	1.0	216.0	60.0			
	GB	1.0	700.0	106.0			
	GB	1.0	576.0	96.0	4812.0		
GLA1	MA	1.0	2153.0	226.0	2153.0		
GLA2	MA2	1.0	1589.0	218.0			
	ATTF	1.0	200.0	60.0	1789.0		
GAR	PP	1.0	520.0	92.0	520.0		
OTH	GB	1.0	1224.0	140.0		<b>COMMENT TABLE 2</b>	
	GB	1.0	884.0	120.0	2108.0	<b>COMMENT TABLE 3</b>	
						MLH 06/06/25	CLEAN UP L4
	Net LIVABLE	cnt	0 (rounded)		3,942		
	Net BUILDING	cnt	5 (rounded)		4,812		

# SKETCH/AREA TABLE ADDENDUM

## SUBJECT INFO

File No.: 536349 Parcel No.: 093W16 00500  
 Property Address: 318 ANKENY HILL RD SE  
 City: JEFFERSON County: State: OR ZipCode: 97352  
 Owner:  
 Client: Client Address:  
 Appraiser Name: Inspection Date:

## SKETCH

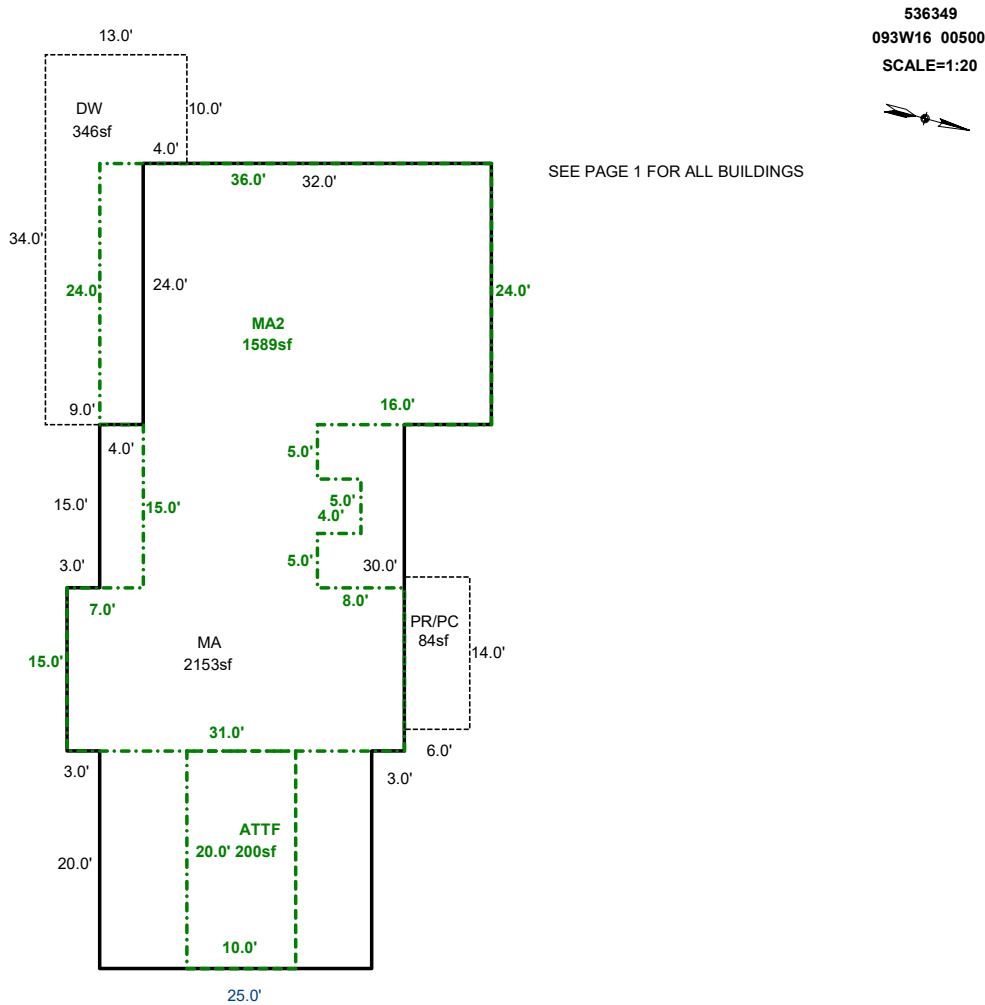

### AREA CALCULATIONS SUMMARY

Code	Description	Factor	Net Size	Perimeter	Net Totals
GLA1	MA	1.0	2153.0	226.0	2153.0
GLA2	MA2	1.0	1589.0	218.0	
	ATTF	1.0	200.0	60.0	1789.0
P/P	PR/PC	1.0	84.0	40.0	
	DW	1.0	346.0	94.0	430.0

### COMMENT TABLE 1

Apex by JA 8/20/09  
 EDITED BY NRC 08/27/2009  
 UPDATED BY JRONDEMA 9/13/18  
 UPDATED BY JRONDEMA 10/16/18  
 UPDATED BY CLOBERG 07/11/25

### COMMENT TABLE 2

MLH 06/06/25

### COMMENT TABLE 3

CLEAN UP L4

Net LIVABLE                      cnt                      0 (rounded)                      3,942

R36349  
093W16 00500  
SCALE=1:60

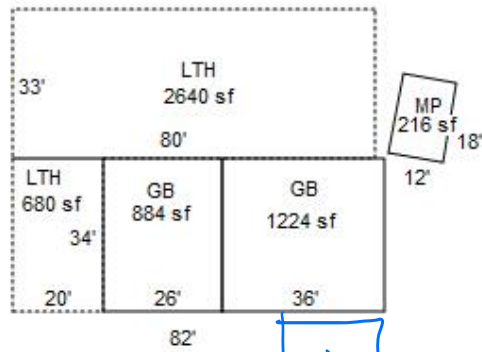

20' 26' PP Car Cover NI

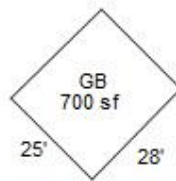

CD 3203 sf

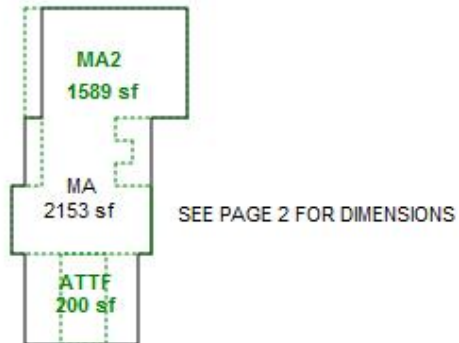

GATE

6/6/25 MLH Clean up  
24