

Acct ID: 536642 MTL: 093W340000200 Date: 4/7/25 Appr: MNL Prop Class: 551 RMV Prop Class: 551
 Situs: 14174 ANANONDA LN SE JEFFERSON OR 97352 MaSaNh: 07 06 000 Unit: 95105 Year: ~~2024~~ 2025
 Last Date Appraised: 11/21/2017 Appraiser: MATT LORD Retag: Y (N) Tag info: _____
 Owner: PROVIDENCE HOLDINGS-JEFFERSON LLC Roll Type: R
 Cycle Tag Sales Verification Other: _____ Inspection level: 1 2 3 4 LCB TTO INSP AV: 189365
 RMV Land: 64510 RMV Imp: 248460 RMV Total: 312970 MAV: 176140 MSAV: 13465 SAV: 22594
 Comment: _____ Farming crops

Notations 25-26 cycle

RP/MS	Code	Description
RP	ZONED	FARM EFU ZONED

OSDs

Count	Code	Description	RMV	Code Area	Exception
1	SAA	SA OSD - AVERAGE	45000	14530	0

Land

Site: 2	Code Area: 14530	Size: 1.00 Acres	Use Code: 005	Zone: REST	SAV Use: 011	Exception: 0
Class: 2BDS S	Value Source: Farm Homesite	Description: TWO BENCH DRY SOUTH SPECIAL	RMV: 4330	Exception: Y	N	
Adjustment(s): GSOIL, IRR		Fire Patrol:	Description:			
Comments: Liability year - 2009 // 09-10: GW39 changed land type per Excel analysis// 81400130						
Site: 3	Code Area: 14530	Size: 3.35 Acres	Use Code: 005	Zone: REST	SAV Use: 011	Exception: 0
Class: 2BISS	Value Source: Farm Use - EFU	Description: TWO BENCH IRR SOUTH SPECIAL	RMV: 15180	Exception: Y	N	
Adjustment(s): GSOIL, IRR		Fire Patrol:	Description:			
Comments: Liability year - 1980 / 81400130						

Improvements - Residence / Manufactured Structures

Bldg: 1	Code Area: 14530	Stat Class: 141 -	Year Blt: 1977	Eff Year Blt: 1977	Sq.Ft: 1608	% Complete: 100
Desc: One Story Only			Dimensions:		RMV: 217490	
Func Obsc: 100	Econ %: 100	Other %: 100	Exception: 0	Adjust:	Adjust RMV: 0	

Floors

Type	Class	Display Group	Floor Size	Beds	Baths	Yr Blt	Eff Yr Blt	Inventory	Exception
First Floor	4 -	Finished	1608	3	FB-1/ HB-1	1977	1977	BATH - 1, BTH - 1, KIT-, HVAC+, FP - 1, ROOF	Y N
Garage Attached	4	Finished	462	0	0	1977	1977	ROOF	Y N

Accessories

Description	Class	Size SqFt	Eff Yr Blt	RMV	Quantity	Exception
YARD IMPROVEMENTS AVERAGE	4	1	1977	21483	1	Y N

Improvements - Accessory Buildings

Bldg: 2	Code Area: 14530	Stat Class: 341	Year Blt: 1980	Eff Year Blt: 1980	Sq.Ft: 967 <u>1400</u>	% Complete: 100
Desc: Multi-Purpose Shed (MP) 6B			Dimensions: 30x16		RMV: 16200	
Func Obsc: 100	Econ %: 100	Other %: 100	Exception: 0	Adjust:	Adjust RMV: 0	

Floors

Type	Class	Display Group	Floor Size	Beds	Baths	Yr Blt	Eff Yr Blt	Inventory	Exception
Finished Office	6	Finished	480	0	FB-1/ HB-1	2007	2007	BTH - 1, FAIR	Y N
Multi-Purpose Bldg	6	Finished	480	0	0	1980	1980	600D	Y N

Accessories

Description	Class	Size SqFt	Eff Yr Blt	RMV	Quantity	Exception
No accessory data available						

Bldg: 3	Code Area: 14530	Stat Class: 351	Year Blt: 1980	Eff Year Blt: 1980	Sq.Ft: 1920	% Complete: 100
Desc: General Purpose Building (GB)			Dimensions: 48x40		RMV: 8000	
Func Obsc: 100	Econ %: 100	Other %: 100	Exception: 0	Adjust:	Adjust RMV: 0	

Floors

Type	Class	Display Group	Floor Size	Beds	Baths	Yr Blt	Eff Yr Blt	Inventory	Exception
General Purpose Bldg	5	Finished	1920	0	0	1980	1980	FAIR ✓	Y N

Accessories

Description	Class	Size SqFt	Eff Yr Blt	RMV	Quantity
No accessory data available					

Bldg: 4 Code Area: 14530 Stat Class: 355 Year Blt: 1980 Eff Year Blt: 1980 Sq.Ft: 1428 % Complete: 100
 Desc: Lean-to Heavy (LTH) ✓
 Dimensions: RMV: 1930
 Func Obsc: 100 Econ %: 100 Other %: 100 Exception: 0 Adjust: Adjust RMV: 0

Floors

Type	Class	Display Group	Floor Size	Beds	Baths	Yr Blt	Eff Yr Blt	Inventory
Lean-to Heavy Duty	4	Finished	1428	0	0	1980	1980	Exception: Y N

Accessories

Description	Class	Size SqFt	Eff Yr Blt	RMV	Quantity
No accessory data available					

Bldg: 5 Code Area: 14530 Stat Class: 353 Year Blt: 1983 Eff Year Blt: 1983 Sq.Ft: 882 % Complete: 100
 Desc: Machine Shed (MS)
 Dimensions: 63x14 RMV: 2690
 Func Obsc: 100 Econ %: 100 Other %: 100 Exception: 0 Adjust: Adjust RMV: 0

Floors

Type	Class	Display Group	Floor Size	Beds	Baths	Yr Blt	Eff Yr Blt	Inventory
Machine Shed	5	Finished	882	0	0	1983	1983	FAIR Exception: Y N

Accessories

Description	Class	Size SqFt	Eff Yr Blt	RMV	Quantity
No accessory data available					

Bldg: 6 Code Area: 14530 Stat Class: 341 Year Blt: Eff Year Blt: Sq.Ft: 80 % Complete: 100
 Desc: Multi Purpose Shed (MP)
 Dimensions: 10x8 RMV: 0
 Func Obsc: 100 Econ %: 100 Other %: 100 Exception: 0 Adjust: Adjust RMV: 0

Floors

Type	Class	Display Group	Floor Size	Beds	Baths	Yr Blt	Eff Yr Blt	Inventory
Multi-Purpose Bldg	5	Finished	80	0	0	0	0	Exception: Y N

Accessories

Description	Class	Size SqFt	Eff Yr Blt	RMV	Quantity
No accessory data available					

Bldg: 7 Code Area: 14530 Stat Class: 341 Year Blt: 2002 Eff Year Blt: 2002 Sq.Ft: 160 % Complete: 100
 Desc: Multi Purpose Shed (MP)
 Dimensions: 10x16 RMV: 2150
 Func Obsc: 100 Econ %: 100 Other %: 100 Exception: 0 Adjust: Adjust RMV: 0

Floors

Type	Class	Display Group	Floor Size	Beds	Baths	Yr Blt	Eff Yr Blt	Inventory
Multi-Purpose Bldg	5	Finished	160	0	0	2002	2002	FAIR Exception: Y N

Accessories

Description	Class	Size SqFt	Eff Yr Blt	RMV	Quantity
No accessory data available					

SKETCH/AREA TABLE ADDENDUM

SUBJECT INFO

File No.: 536642 Parcel No.: 093W34 00200
 Property Address: 14174 ANANONDA LN SE
 City: JEFFERSON County: MARION State: OR ZipCode: 97352
 Owner:
 Client: Client Address:
 Appraiser Name: Inspection Date:

SKETCH

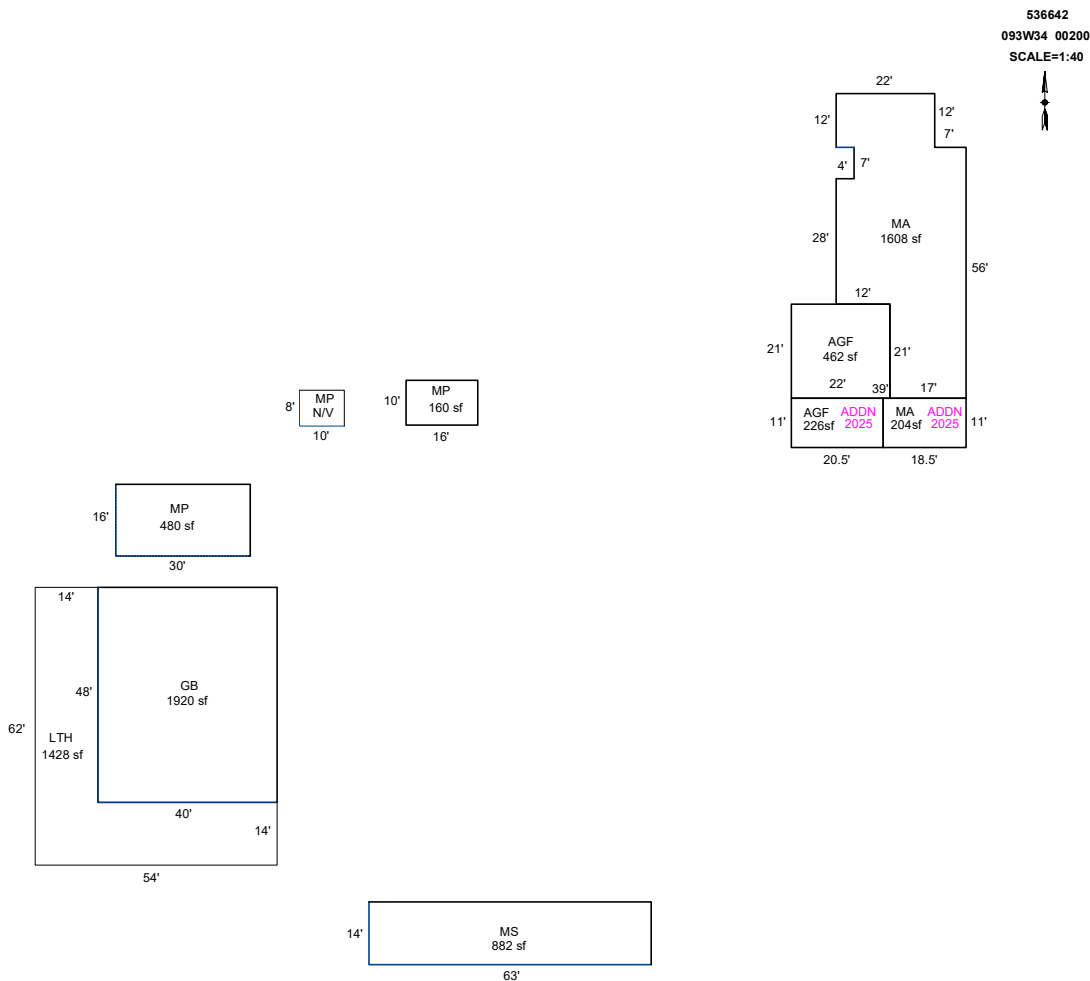

Sketch by ApexSketch

AREA CALCULATIONS SUMMARY						COMMENT TABLE 1	
Code	Description	Factor	Net Size	Perimeter	Net Totals		
GBA1	MP	1.0	480.0	92.0		DRAWN BY JRONDEMA 6/27/18 UPDATED BY CLOBERG 01/23/25 24-009732 ADDN UPDATED BY CLOBERG 07/16/25	
	GB	1.0	1920.0	176.0			
	LTH	1.0	1428.0	232.0			
	MP	1.0	160.0	52.0			
	MS	1.0	882.0	154.0	4870.0		
GLA1	MA	1.0	1608.0	202.0	1608.0		
GAR	AGF	1.0	462.0	86.0			
	AGF	1.0	225.5	63.0	687.5		
MA	MA	1.0	203.5	59.0	203.5		
						COMMENT TABLE 2	COMMENT TABLE 3
						MDL 04/07/25	CYCLE L3
		Net LIVABLE	cnt	1 (rounded)	1,812		
		Net BUILDING	cnt	5 (rounded)	4,870		

