

Acct ID: 530366 MTL: 082W24B002600 Date: 7/3/25 Appr: MDL Prop Class: 401 RMV Prop Class: 401
 Situs: 8627 BRONCO DR SE SALEM OR 97317 MaSaNh: 07 06 000 Unit: 47222 Year: 2025

Last Date Appraised: 12/08/2014 Appraiser: MATT LORD Retag: Y N Tag info:
 Owner: SPENCER, BOBBI R & SPENCER, RONALD H Roll Type: R
 Cycle: 3 Tag Sales Verification Other: _____ Inspection level: 1 2 3 4 LCB TTO INSP AV: 282090
 RMV Land: 264540 RMV Imp: 344910 RMV Total: 609450 MAV: 282090 MSAV: 0 SAV: 0
 Comment:

Notations 25-26 cycle
 No notation data available.

OSDs

Count	Code	Description	RMV	Code Area	Exception
1	MKTG	OSD - <u>GOOD</u> <u>AV6</u>	60000	05558	0

Land

Site: 1 Code Area: 05558 Size: 1.38 Acres Use Code: 004 Zone: NREST SAV Use: Exception: 0
 Class: 4BDS Value Source: Rural at MKT Description: RMV: 204540 Exception: Y N
 Adjustment(s): Fire Patrol: Description:
 Comments: 15-16: SV PER #36 CHG OSD// 2002-03 REAPPRAISAL; 2003-04 MODIFIED LAND TABLE KKB65 10/02

Improvements - Residence / Manufactured Structures

Bldg: 1 Code Area: 05558 Stat Class: 141 Year Blt: 1947 Eff Year Blt: 1988 Sq.Ft: 1582 % Complete: 100
 Desc: One Story Only Dimensions: RMV: 279890
 Func Obsc: 100 Econ %: 100 Other %: 100 Exception: 0 Adjust: Adjust RMV: 0

Floors

Type	Class	Display Group	Floor Size	Beds	Baths	Yr Blt	Eff Yr Blt	Inventory	Exception
First Floor	4	Finished	1582	3	FB-1/ HB-1	1947	1988	ROOF, FP - 1, HVAC+, KIT, BTH - 1, BATH - 1	Y N
Garage Attached	4	Unfinished	650	0	0	1947	1988	ROOF	Y N

Accessories

Description	Class	Size SqFt	Eff Yr Blt	RMV	Quantity
YARD IMPROVEMENTS <u>FAIR</u> <u>Ac/b</u>	4	1	1988	15793	1

Bldg: 3 ✓ Code Area: 05558 Stat Class: 138 Year Blt: 2008 Eff Year Blt: 2008 Sq.Ft: 0 % Complete: 100
 Desc: Res other improvements Dimensions: RMV: 58250
 Func Obsc: 100 Econ %: 100 Other %: 100 Exception: 0 Adjust: Adjust RMV: 0

Floors

Type	Class	Display Group	Floor Size	Beds	Baths	Yr Blt	Eff Yr Blt	Inventory	Exception
Garage Detached	3	Unfinished	832	0	0	2008	2008	ROOF	Y N

Accessories

Description	Class	Size SqFt	Eff Yr Blt	RMV	Quantity
No accessory data available					

Improvements - Accessory Buildings

Bldg: 2 Code Area: 05558 Stat Class: 341 Year Blt: 1997 Eff Year Blt: 1997 Sq.Ft: 384 % Complete: 100
 Desc: Multi Purpose Shed (MP) Dimensions: 32x12 RMV: 6770
 Func Obsc: 100 Econ %: 100 Other %: 100 Exception: 0 Adjust: Adjust RMV: 0

Floors

Type	Class	Display Group	Floor Size	Beds	Baths	Yr Blt	Eff Yr Blt	Inventory	Exception
Multi-Purpose Bldg	6	Finished	384	0	0	1997	1997	FAIR <u>✓</u>	Y N

Accessories

Description	Class	Size SqFt	Eff Yr Blt	RMV	Quantity
No accessory data available					

R30366
082W24B 02600

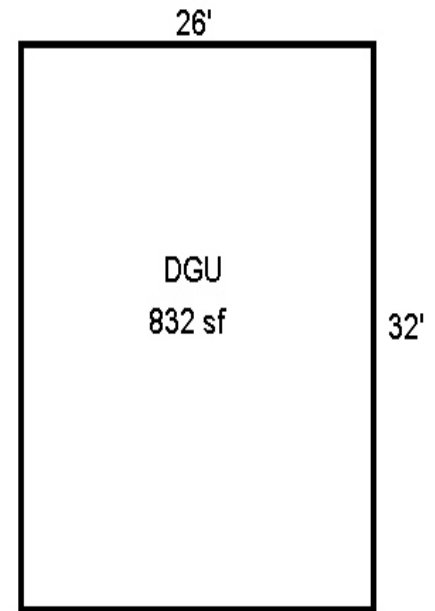
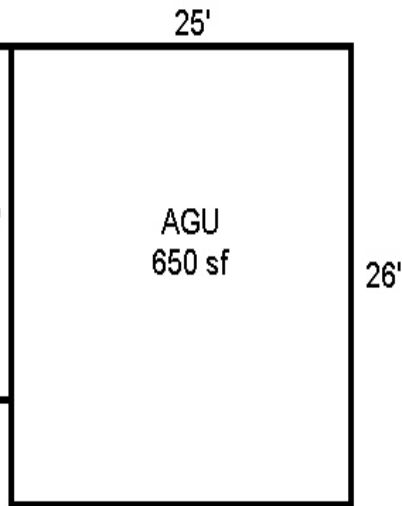
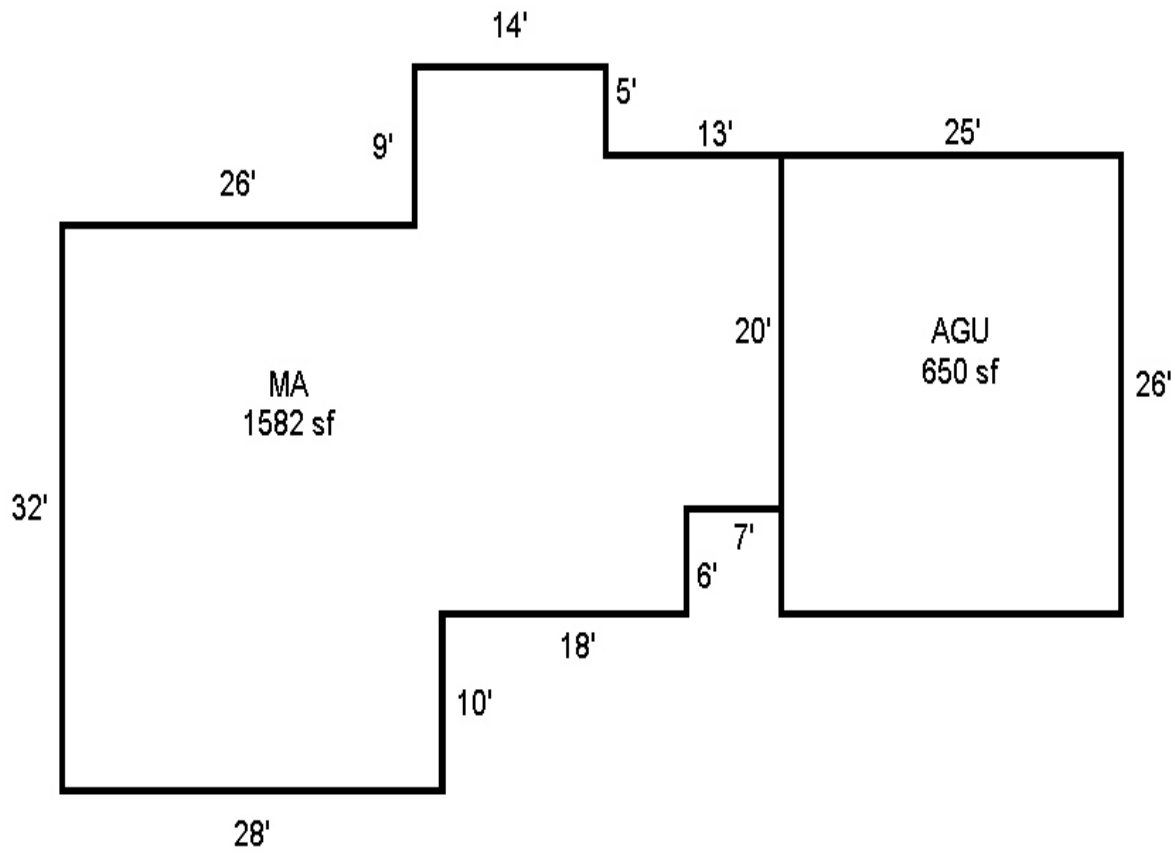
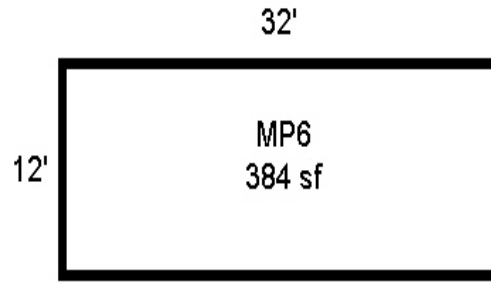



082W24B 02600
401 01D F41
00560050

R30366

BOWEN,ERIC A & CHRISTINE

1.38 Acres

8620 AUMSVILLE HY SE

1/30/02

SKETCH/AREA TABLE ADDENDUM

Parcel No 082W24B 02600

File No R30366

SUBJECT

Property Address 8627 BRONCO DR SE

City SALEM

State OR

Zip 97317

Owner

Client

Appraiser Name

IMPROVEMENTS SKETCH

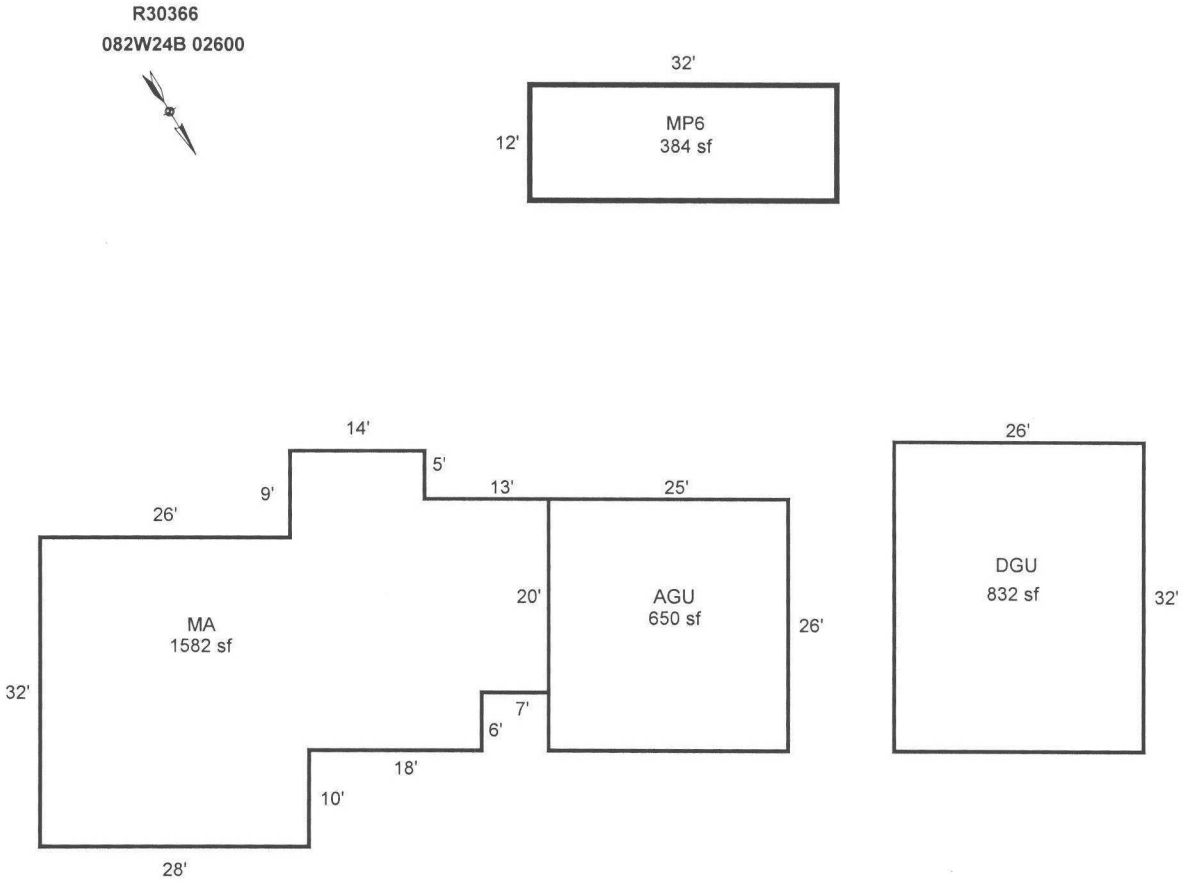

AREA CALCULATIONS

AREA CALCULATIONS SUMMARY

Code	Description	Factor	Net Size	Perimeter	Net Totals
GLA1	MA	1.00	1582	188	1582
GBA1	MP6	1.00	384	88	384
GAR	AGU	1.00	650	102	650
	DGU	1.00	832	116	1482

Comment Table 1

APEX BY CE 1/5/09

Comment Table 2

Comment Table 3

Net LIVABLE Area	(Rounded w/ Factors)	1582
Net BUILDING Area	(Rounded w/ Factors)	384

R30366 082W24B 02600 Appr #: 36 Date 9/26/14 Prop Class 401 Prop Code F41
 Situs Address 8627 BRONCO DR SE 97317 Franchise Code 36 Year For: **2014-2015**
 Owner SHRYOCK, PATRICIA E & 15-16

Notes: Update inventory 12/8/14 Cycle Sales Verification Add AC. Charge O.S.D.'s. Other: _____

RMV Land: 91,750 RMV Imp: 138,730 RMV Total: 230,480 M50 Total: 203,840

Seg.Type MA Seg. # 1.1 Method: R05 Class 4 Area 1582 Eff Area 1582
 Length Width Roof Cover COMP Plumbing BATH1.5 Heat ZONAL
 Fireplace SGL-P Inter. Comp: DW;H&F;DSP Bedrooms 3
 Year Built 1947 Eff. Year Built 1968 Cond. P F (A) G E
 Adj Codes RLCM4 Qty ___ % Comp ___ Func ___ Econ ___ RMV: 83,240
 Lump Sum _____ Except Code/Year _____ Comments _____

Seg.Type AGU Seg. # 1.2 Method: R05 Class 4 Area 650 Eff Area 650
 Length 26 Width 25 Roof Cover COMP Plumbing Heat
 Fireplace Inter. Comp: Bedrooms
 Year Built 1947 Eff. Year Built 1968 Cond. P F (A) G E
 Adj Codes RLCM4 Qty ___ % Comp ___ Func ___ Econ ___ RMV: 19,930
 Lump Sum _____ Except Code/Year _____ Comments _____

Accessory Improvements

Seg.Type YI4F Seg. # 1.3 Method: R05 Class Area 1 Eff Area 1
 Length Width Foundation Ex. Wall Roof Cover
 Roof Style Floor Plumbing
 Year Built Eff. Year Built: Cond. P (F) A G E % Comp ___ Econ ___ RMV: 5,000
 Lump Sum _____ Except Code/Year _____ Comments _____

Out Buildings

Seg.Type MP Seg. # 2.1 Method: F09 Class 6 Area 384 Eff Area 384
 Length 32 Width 12 Foundation CONC Ex. Wall PLYWD Roof Cover COMP
 Roof Style Floor CONC Plumbing
 Heat Int. Comp. Elect. 110V Yr. Blt. Eff. Yr. Blt: 1985
 Cond. P F (A) G E Adj. Codes FLCM % Comp ___ Func ___ Econ ___ RMV: 4,790 1997
 Lump Sum _____ Except Code/Year _____ Comments _____

Seg.Type DGU Seg. # 3.1 Method: R05 Class 3 Area 832 Eff Area 832
 Length 26 Width 32 Foundation Ex. Wall LAP;14FT Roof Cover ARCOMP
 Roof Style HIP Floor Plumbing
 Heat Int. Comp. Elect. Yr. Blt. 2008 Eff. Yr. Blt: 2008
 Cond. P F (A) G E Adj. Codes RLCM3 % Comp ___ Func ___ Econ ___ RMV: 25,770
 Lump Sum _____ Except Code/Year _____ Comments _____

R30366 082W24B 02600 Appr #: 36 Date 9/26/14 Prop Class 401 Prop Code F41
 Situs Address 8627 BRONCO DR SE 97317 Franchise Code 36 Year For: 2014-2015
 Owner SHRYOCK, PATRICIA E & 15-16

Tags Cycle Sales Verification Other: _____

Notes: _____
 RMV Land: 91,750 RMV Imp: 138,730 RMV Total: 230,480 M50 Total: 203,840

Segment							Land
Class							
Dim/Size							
Foundation							
Exter Wall							
Wall Height							
Inter Finish							
Roof Cover							
Roof Style							
Flooring							
Plumbing							
Electric							
Misc.							
Yr Blt							
Eff Yr							
Cond.							
% Good							
% Comp							
Lump Sum							
Except.Code							

Land Segments

Seg. No	Description	Schedule	Acres	Adjustment Codes	Exception Code
1	RURAL AT MKT	008S	1.38		
2	ON SITE DEVELOPMENT	OSDA.RUR		<u>OSDG.RUR</u>	

Eff Acres _____ Companion Accounts _____

Zone: AR

OK 12/8/14
OK #36 DB 12/11/14

Date 10/3/14 Clerk Chris **ROUTING SLIP**

Work Needed: (Please make necessary comments, sign and pass to the next appropriate person.)

- Data entry reviewed by/comments _____
- APEX: Please review and return appraisal jacket to clerical staff for Apex attachment to TSG.
- Appraiser response OK #36 DB 10/14/14
- Reviewed by lead appraiser/comments _____





R30366 082W24B 02600 EW49 8/16/07, MP6

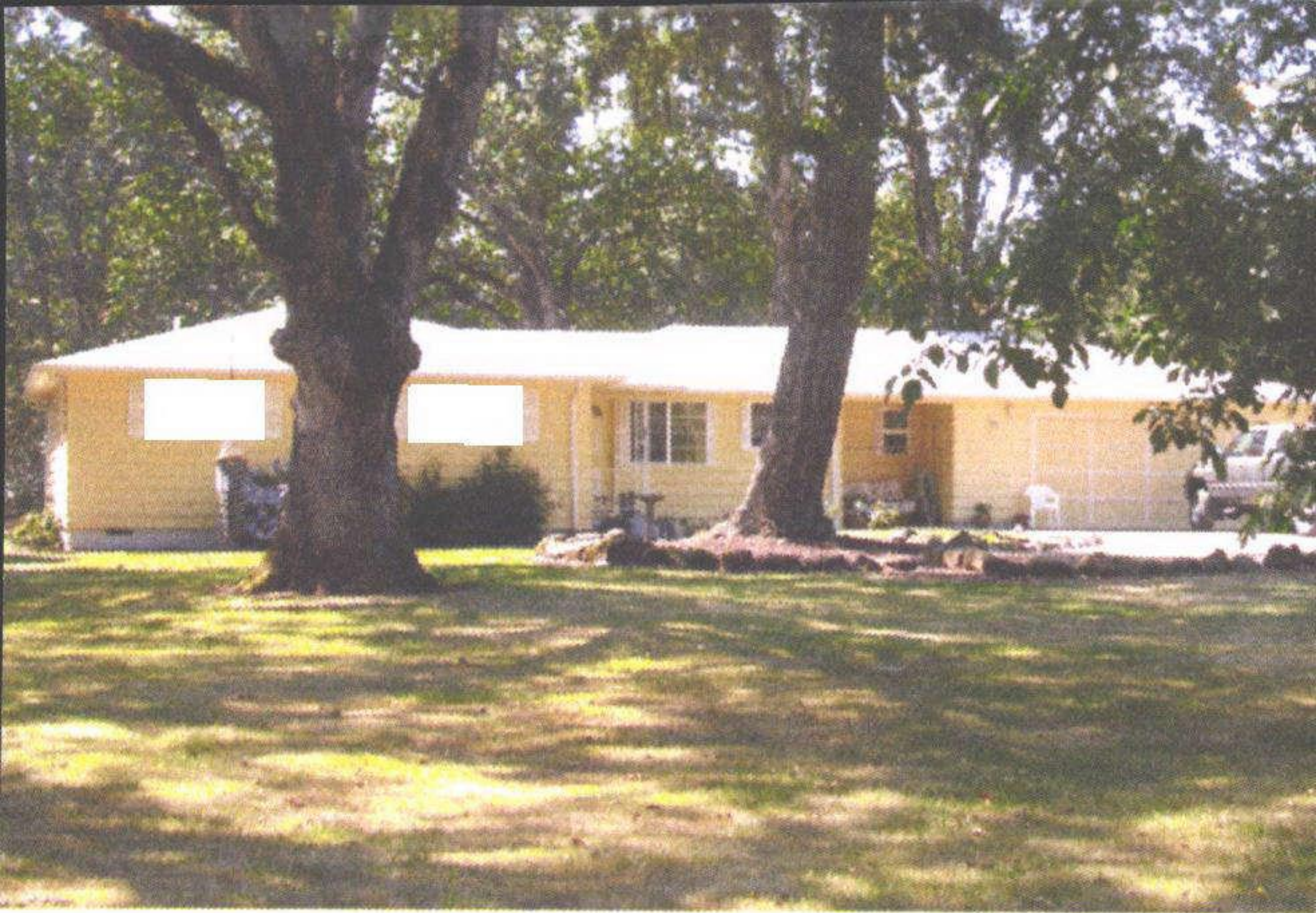

R30366 082W24B 02600 EW49 8/16/07



DGU 12/29/08 R30366