

Acct ID: 535034 MTL: 092W01B000100 Date: 7/24/25 Appr: MDC Prop Class: 559 RMV Prop Class: 459
 Situs: 8983 WEST STAYTON RD SE AUMSVILLE OR 97325 MaSaNh: 07 06 000 Unit: 28156 Year: 2025

Last Date Appraised: 06/16/2025 Appraiser: MATT LORD Retag: Y N Tag info: 2026 - Tags/Permit (Demolished)

Owner: STORMS, KEITH Roll Type: R

Cycle Tag Sales Verification Other: MS Inspection level: 1 2 3 4 LCB TTO INSP AV: 558012

RMV Land: 171030 RMV Imp: 535470 RMV Total: 706500 MAV: 21470 MSAV: 22542 SAV: 43068

Comment: 25-26: L4 MDL 6.16.25 F/F
 25-26: L3 MDL 1.13.25 TAG
 24-25 L4 3.28.24 MDL
 24-25 L4 2.7.24 MDL

Notations

25-26 MS BONE 6/25 Tagged For 1/1/26

RP/MS	Code	Description
MS	ZONED	FARM EFU ZONED
MS	ZONED	FARM EFU ZONED
MS	ZONED	FARM EFU ZONED

OSDs

Count	Code	Description	RMV	Code Area	Exception
1	SAF	SA OSD - FAIR	40000	05555	0

Land

Site: 2 Code Area: 05555 Size: 1.00 Acres Use Code: 005 Zone: REST SAV Use: 011 Exception: 0
 Class: 4BDS Value Source: Farm Homesite Description: FOUR BENCH DRY SPECIAL SOUTH RMV: 25200 Exception: Y N
 S
 Adjustment(s): IRR Fire Patrol: Description:
 Comments: Liability year - 2009
 24-25: Update land classes

Site: 3 Code Area: 05555 Size: 4.00 Acres Use Code: 005 Zone: REST SAV Use: 011 Exception: 0
 Class: 4BISS Value Source: Farm Use - EFU Description: FOUR BENCH IRR SPECIAL SOUTH RMV: 105830 Exception: Y N
 Adjustment(s): IRR Fire Patrol: Description:
 Comments: Liability year - 1982
 25-26: Land classes ok

Improvements - Residence / Manufactured Structures

Bldg: 1 Code Area: 05555 Stat Class: 444 Year Blt: 1975 Eff Year Blt: 1975 Sq.Ft: 1164 % Complete: 100
 Desc: MANUF STRUCT, CLASS 4, 14' WIDE SINGLE Dimensions: 66x14 RMV: 0
 Func Obsc: 100 Econ %: 100 Other %: 100 Exception: 0 Adjust: Adjust RMV: 0

Floors

Type	Class	Display Group	Floor Size	Beds	Baths	Yr Blt	Eff Yr Blt	Inventory	Exception
First Floor	4	Finished	1164	3	FB-1/ HB-1	1975	1975	SKIRT, KIT-, BATH - 1, ROOF, HVAC, BTH - 1	Y N

Accessories

Description	Class	Size SqFt	Eff Yr Blt	RMV	Quantity
No accessory data available					

Bldg: 2 Code Area: 05555 Stat Class: 141 Year Blt: 2024 Eff Year Blt: 2024 Sq.Ft: 2658 % Complete: 100
 Desc: One Story Only Dimensions: RMV: 525230
 Func Obsc: 100 Econ %: 100 Other %: 100 Exception: 525230 Adjust: Adjust RMV: 0

Floors

Type	Class	Display Group	Floor Size	Beds	Baths	Yr Blt	Eff Yr Blt	Inventory	Exception
First Floor	4	Finished	2658	3	FB-2/ HB-1	2024	2024	FP - 1, BTH - 1, BATH - 2, ROOF, KIT, HVAC	Y N
Garage Attached	4	Finished	816	0	0	2024	2024	ROOF	Y N

Accessories

Description	Class	Size SqFt	Eff Yr Blt	RMV	Quantity
YARD IMPROVEMENTS AVERAGE	4	0	2024	32100	1

Improvements - Accessory Buildings

Bldg: 1 Code Area: 05555 Stat Class: 351 Year Blt: 1992 Eff Year Blt: 1992 Sq.Ft: 1920 % Complete: 100
 Desc: General Purpose Building (GB) Dimensions: 60x32 RMV: 10240
 Func Obsc: 100 Econ %: 100 Other %: 100 Exception: 0 Adjust: Adjust RMV: 0

Floors

Type	Class	Display Group	Floor Size	Beds	Baths	Yr Blt	Eff Yr Blt	Inventory	Exception: Y N
General Purpose Bldg	4	Finished	1920	0	0	1992	1992	FAIR	

Accessories

Description	Class	Size SqFt	Eff Yr Blt	RMV	Quantity
No accessory data available					

SKETCH/AREA TABLE ADDENDUM

SUBJECT INFO

File No.: 535034 Parcel No.: 092W01B 00100
 Property Address: 8983 West Stayton Rd SE
 City: Aumsville County: Marion State: OR ZipCode: 97325
 Owner:
 Client: Client Address:
 Appraiser Name: Inspection Date:

SKETCH

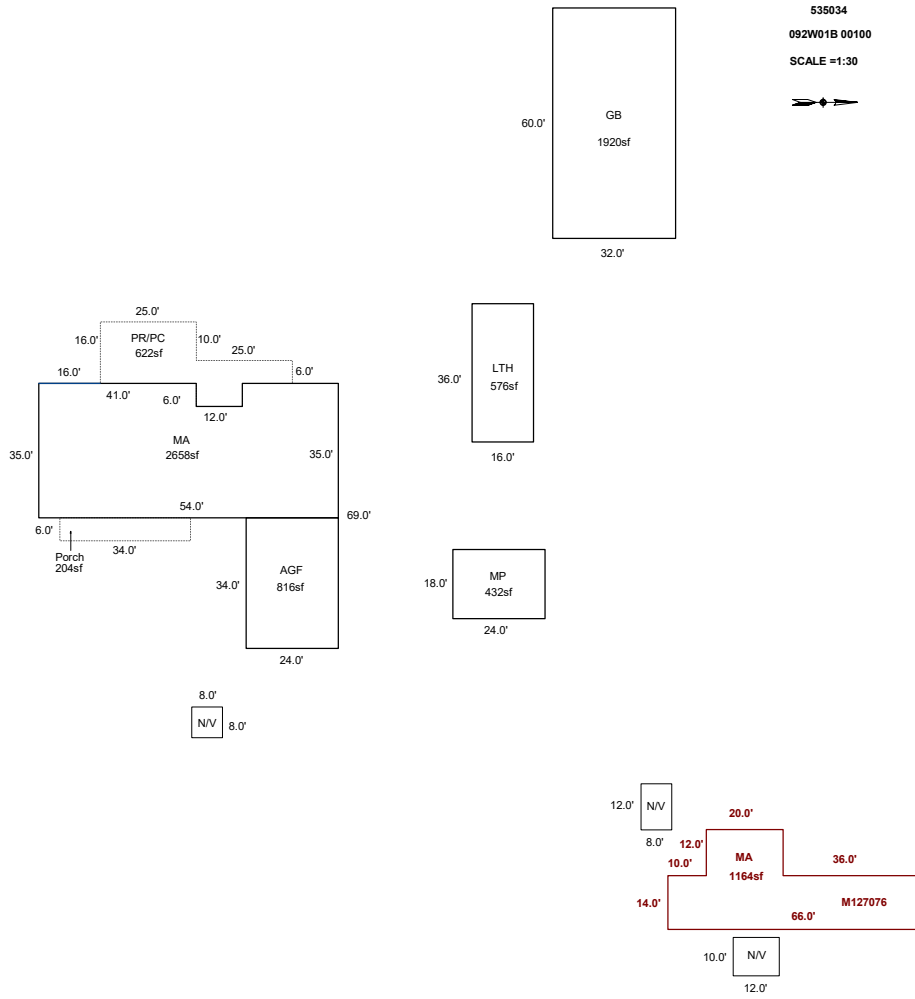

AREA CALCULATIONS SUMMARY

Code	Description	Factor	Net Size	Perimeter	Net Totals
GBA1	GB	1.0	1920.0	184.0	
	MP	1.0	432.0	84.0	
	LTH	1.0	576.0	104.0	2928.0
GLA1	MA	1.0	1164.0	184.0	
	MA	1.0	2658.0	238.0	3822.0
GAR	AGF	1.0	816.0	116.0	816.0
P/P	Porch	1.0	204.0	80.0	
	PR/PC	1.0	622.0	144.0	826.0
	Net LIVABLE	cnt	2 (rounded)		3,822
	Net BUILDING	cnt	3 (rounded)		2,928

COMMENT TABLE 1

Apex by RW 05/29/08
 UPDATED BY JRONDEMA 11/2/16
 UPDATED BY WWILLIAMS 4/11/24
 UPDATED BY CLOBERG 07/08/2024 24-003422 MA

COMMENT TABLE 2

#36 DB 10/14/16
 JJS 2.7.24

COMMENT TABLE 3

TAGS L4

SKETCH/AREA TABLE ADDENDUM

SUBJECT INFO

File No.: 535034 Parcel No.: 092W01B 00100
 Property Address: 8983 West Stayton Rd SE
 City: Aumsville County: Marion State: OR ZipCode: 97325
 Owner:
 Client: Client Address:
 Appraiser Name: Inspection Date:

SKETCH

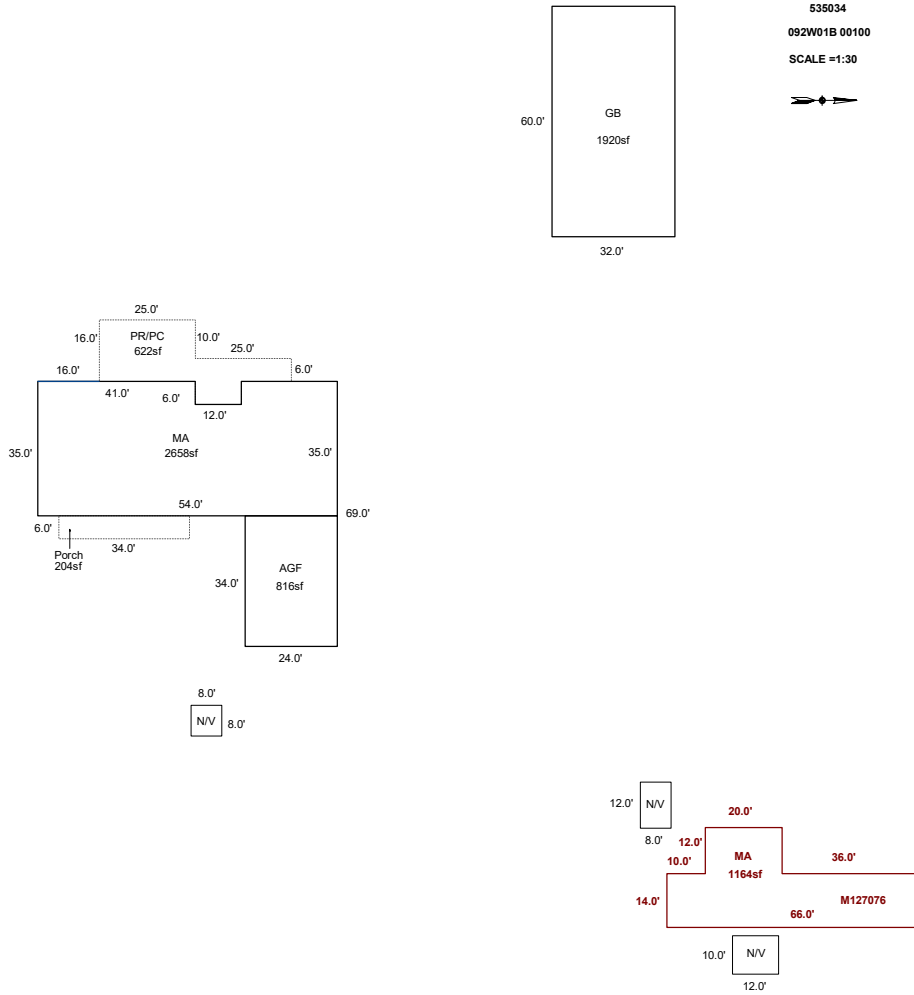

AREA CALCULATIONS SUMMARY

Code	Description	Factor	Net Size	Perimeter	Net Totals
GBA1	GB	1.0	1920.0	184.0	1920.0
GLA1	MA	1.0	1164.0	184.0	
	MA	1.0	2658.0	238.0	3822.0
GAR	AGF	1.0	816.0	116.0	816.0
P/P	Porch	1.0	204.0	80.0	
	PR/PC	1.0	622.0	144.0	826.0

COMMENT TABLE 1

Apex by RW 05/29/08
 UPDATED BY JRONDEMA 11/2/16
 UPDATED BY WWILLIAMS 4/11/24
 UPDATED BY CLOBERG 07/08/2024 24-003422 MA
 UPDATED BY CLOBERG 01/30/25

COMMENT TABLE 2

#36 DB 10/14/16
 JJS 2.7.24
 MDL 01/13/25

COMMENT TABLE 3

TAGS L4
 TAGS L2

Net LIVABLE	cnt	0	(rounded)	3,822
Net BUILDING	cnt	1	(rounded)	1,920

R35034
092W01B 00100
SCALE=1:50
N

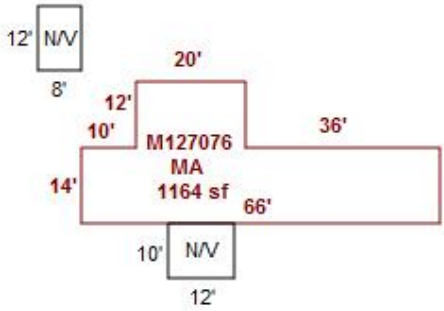
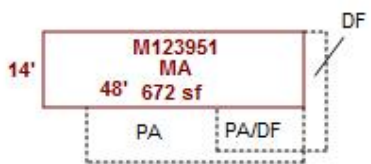
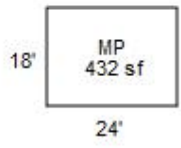
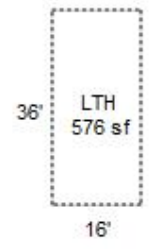
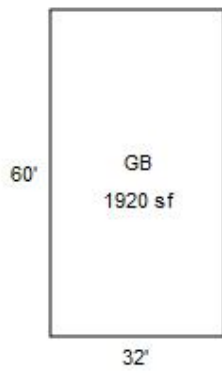

SKETCH/AREA TABLE ADDENDUM

SUBJECT INFO

File No.: R35034 Parcel No.: 092W01B 00100
 Property Address: 8983 West Stayton Rd SE
 City: Aumsville County: State: OR ZipCode: 97325
 Owner:
 Client: Client Address:
 Appraiser Name: Inspection Date:

SKETCH

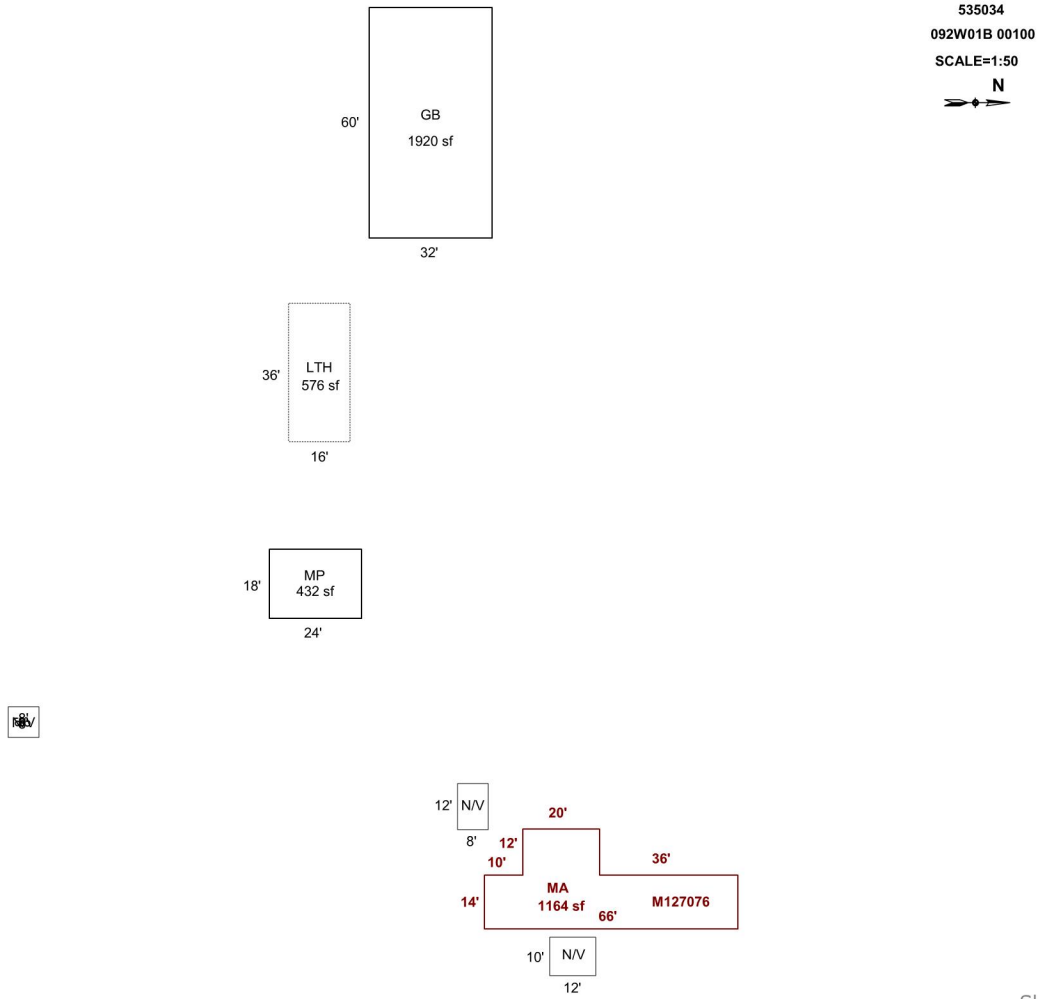

AREA CALCULATIONS SUMMARY

Code	Description	Factor	Net Size	Perimeter	Net Totals
GBA1	GB	1.0	1920.0	184.0	
	MP	1.0	432.0	84.0	
	LTH	1.0	576.0	104.0	2928.0
GLA1	MA	1.0	1164.0	184.0	1164.0

COMMENT TABLE 1

Apex by RW 05/29/08
 UPDATED BY JRONDEMA 11/2/16
 UPDATED BY WWILLIAMS 4/11/24

COMMENT TABLE 2

#36 DB 10/14/16
 JJS 2.7.24

COMMENT TABLE 3

TAGS L4

Net LIVABLE	cnt	1	(rounded)	1,164
Net BUILDING	cnt	3	(rounded)	2,928

092W01B 00100
551 01D A29E
00550050

R35034

00550050

COOK,ARNOLD R & DONNA MAE-TRUST
5 Acres
8983 W STAYTON RD SE

1/30/02

BUILDING DIAGRAM AND OUTBUILDINGS

ACCT. NO. 61385 000

MAP NO. 1-9-2W

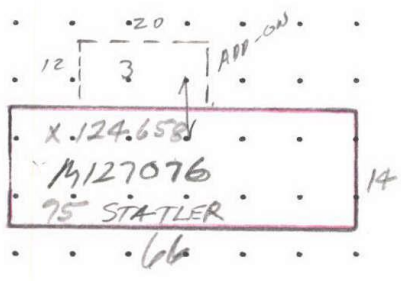
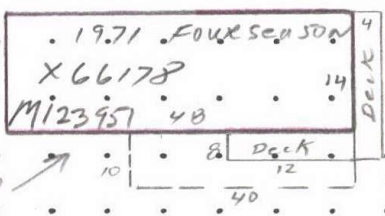
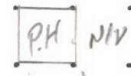
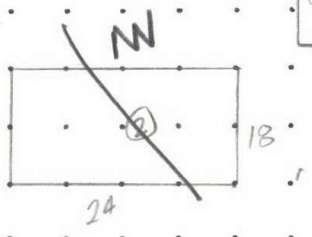
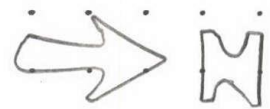

These Imp. valued with MH

8983 W STAYTON RD SE

MEASUREMENT VERIFIED		REMARKS:
DATE	BY	
4-14-87	REYES	Both MH sharing same septic & well MH X 66178 move in 1986
1-7-92	KEN #82 VER	

SKETCH/AREA TABLE ADDENDUM

Parcel No 092W01B 00100

File No R35034

SUBJECT

Property Address 8983 West Stayton Rd SE

City Aumsville

State OR

Zip 97325

Owner

Client

Appraiser Name

IMPROVEMENTS SKETCH

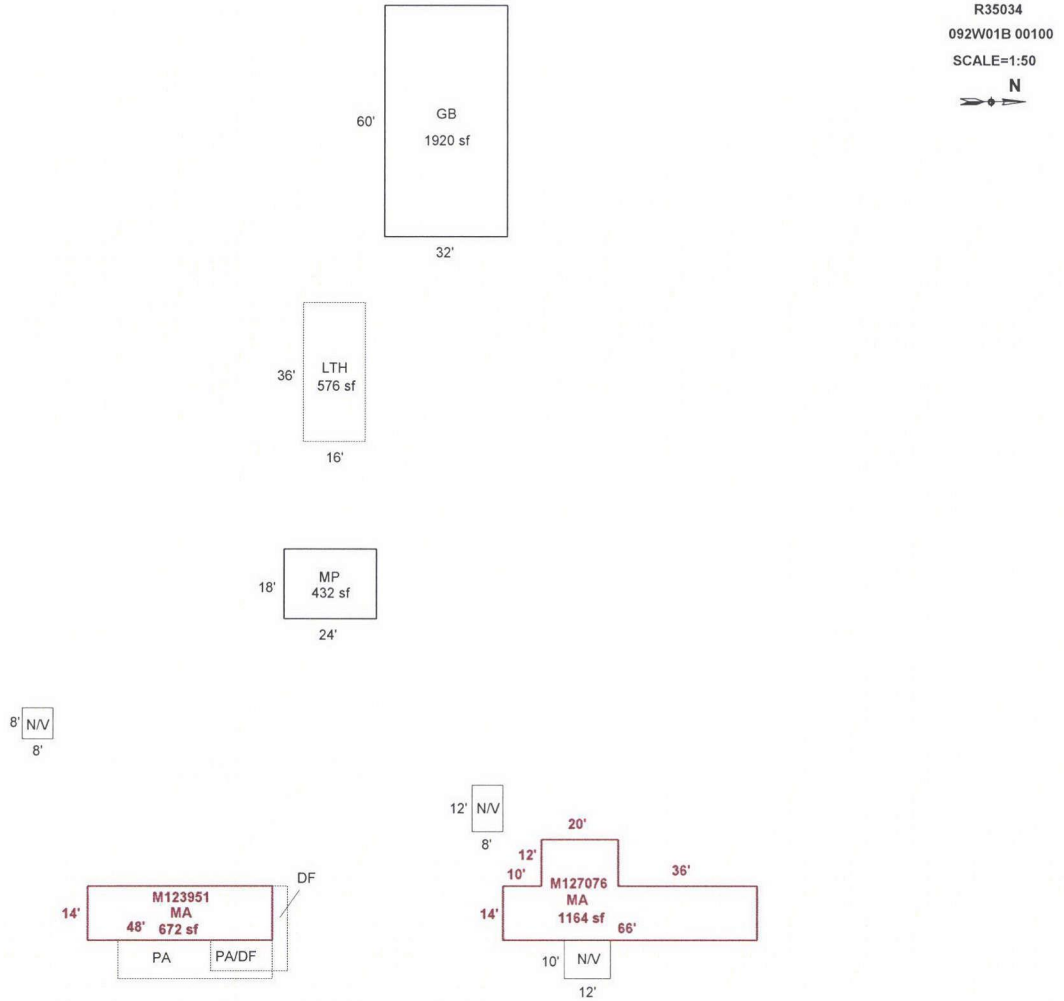

Scale: 1" = 50'

AREA CALCULATIONS

AREA CALCULATIONS SUMMARY

Code	Description	Factor	Net Size	Perimeter	Net Totals
GLA1	MA	1.00	672	124	1836
	MA	1.00	1164	184	
GBA1	GB	1.00	1920	184	2928
	MP	1.00	432	84	
	LTH	1.00	576	104	
Net LIVABLE Area		(rounded w/ factors)			1836
Net BUILDING Area		(rounded w/ factors)			2928

Comment Table 1

Apex by RW 05/29/08
UPDATED BY JRONDEMA 11/2/16

Comment Table 2

#36 DB 10/14/16

Comment Table 3

R35034 092W01B 00100 Appr #: 36 Date 10/14/16 Prop Class 551 Prop Code A99E
 Situs Address 8983 WEST STAYTON RD SE 97325 Franchise Code 36 Year For: ~~2016-2017~~
 Owner ARNOLD B & DONNA MAE COOK FAM TR & 17-18

Tags Cycle Sales Verification Other: _____

Notes: _____

RMV Land: **95,500** RMV Imp: **10,410** RMV Total: **105,910** M50 Total: **27,920**

Segment							Land
Class							
Dim/Size							
Foundation							
Exter Wall							
Wall Height							
Inter Finish							
Roof Cover							
Roof Style							
Flooring							
Plumbing							
Electric							
Misc.							
Yr Blt							
Eff Yr							
Cond.							
% Good							
% Comp							
Lump Sum							
Except.Code							

Land Segments

Seg. No	Description	Schedule	Acres	Adjustment Codes	Exception Code
1	FARM OSD	OSDF.RUR	0.00		
2	FARM HOMESITE	008S	1.00		
3	FOUR BENCH DRY	008S	4.00		

Eff Acres 15.00 Companion Accounts M127076 092W01B 01500
 M123577
 M123951 R35033

Zone: EFU

Date 11/1/16 Clerk Chris **ROUTING SLIP**

Work Needed: (Please make necessary comments, sign and pass to the next appropriate person.)

Data entry reviewed by/comments _____

APEX: Please review and return appraisal jacket to clerical staff for Apex attachment to TSG.

Appraiser response OK #36 DB 11/25/16

Reviewed by lead appraiser/comments 10/28/16 (36)

R35034 092W01B 00100 Appr #: 36 Date 10/14/16 Prop Class 551 Prop Code A99E
 Situs Address 8983 WEST STAYTON RD SE 97325 Franchise Code 36 Year For: 2016-2017
 Owner ARNOLD B & DONNA MAE COOK FAM TR & 17-18

Notes: Change GB EYB Tags Cycle Sales Verification Other: _____

RMV Land: 95,500 RMV Imp: 10,410 RMV Total: 105,910 M50 Total: 27,920

Accessory Improvements

Out Buildings

Seg.Type GB GENERAL PURPO Seg. # 1.1 Method: F09 Class 5 Area 1920 Eff Area 1920
 Length 60 Width 32 Foundation POST Ex. Wall 10FT;PLYWD Roof Cover METAL
 Roof Style Floor CONC Plumbing
 Heat Int. Comp. Elect. Yr. Blt. Eff. Yr. Blt: ¹⁹⁹²1984
 Cond. P (F) A G E Adj. Codes FLCM % Comp ____ Func ____ Econ ____ RMV: 9,260
 Lump Sum _____ Except Code/Year _____ Comments _____

Seg.Type MP MULTI/MISC PUR Seg. # 2.1 Method: F;N Class 4 Area 432 Eff Area 432
 Length 24 Width 18 Foundation FRAME Ex. Wall 8FT;PLYWD Roof Cover METAL
 Roof Style Floor WOOD Plumbing
 Heat Int. Comp. Elect. NV Yr. Blt. Eff. Yr. Blt: 1986
 Cond. (P) F A G E Adj. Codes FLCM % Comp ____ Func ____ Econ ____ RMV: 0
 Lump Sum _____ Except Code/Year _____ Comments _____

Seg.Type LTH LTH Seg. # 3.1 Method: F09 Class Area 576 Eff Area 576
 Length 36 Width 16 Foundation POST Ex. Wall 10FT;METAL Roof Cover METAL
 Roof Style Floor DIRT Plumbing
 Heat Int. Comp. Elect. Yr. Blt. Eff. Yr. Blt: 1986
 Cond. P (F) A G E Adj. Codes FLCM % Comp ____ Func ____ Econ ____ RMV: 1,150
 Lump Sum _____ Except Code/Year _____ Comments _____



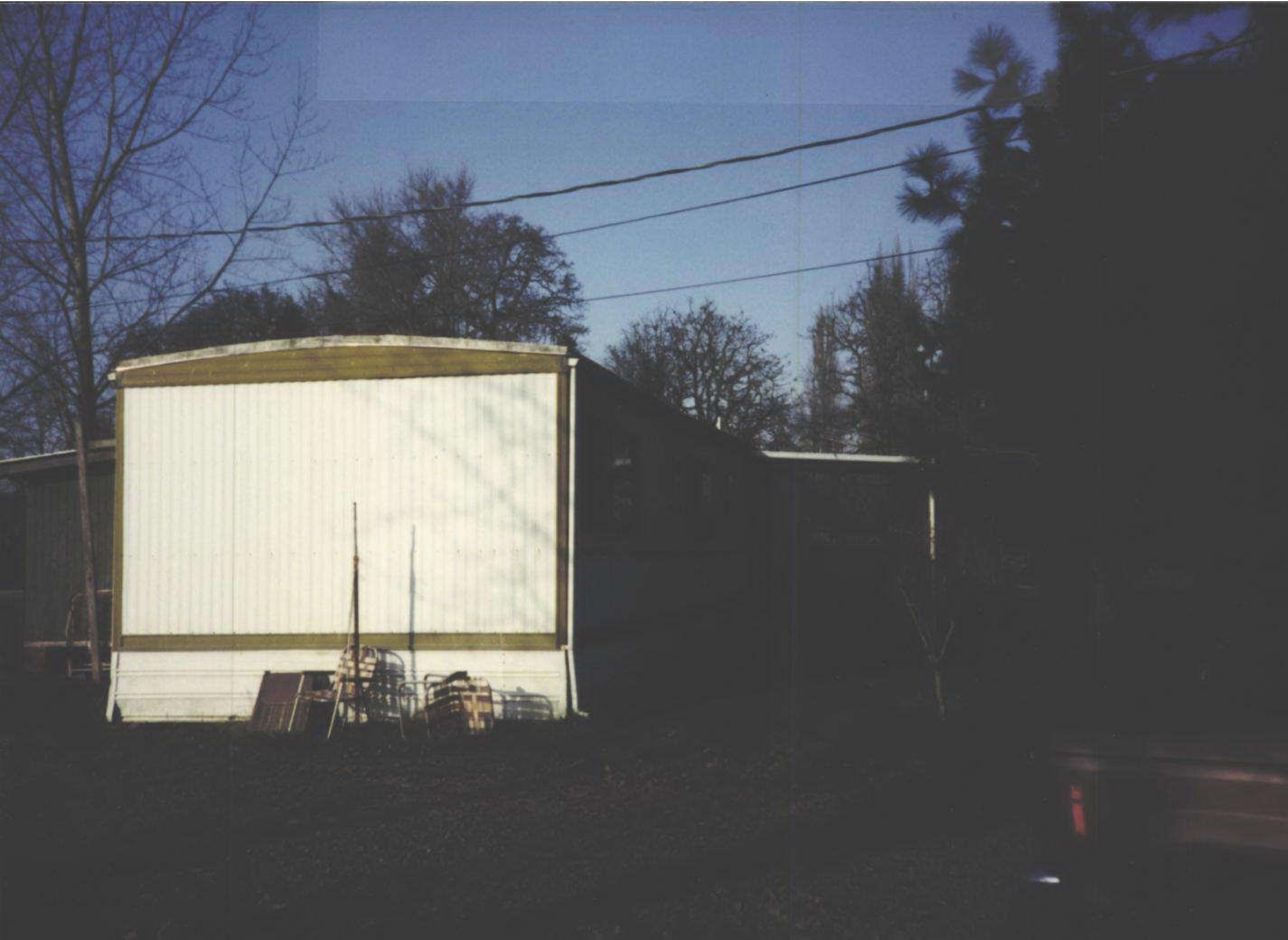



EW49 6/13/08

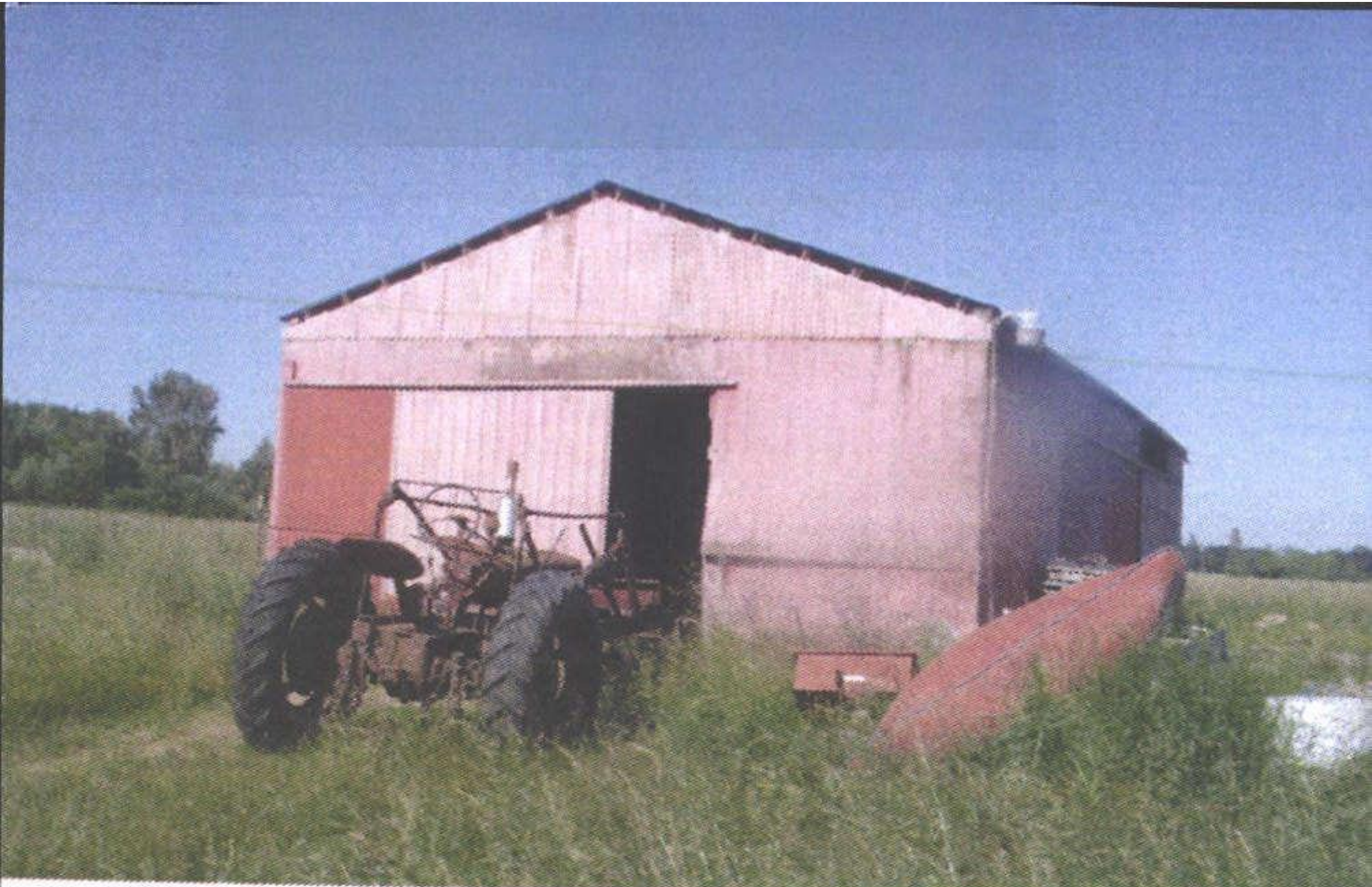

GB5

EW49 6/13/08



MPT NV

EW 49 6/13/09



LTH

EW49

6/13/08

Acct ID: 535034 MTL: 092W01B000100 Date: 6/16/25 Appr: MDL Prop Class: 559 RMV Prop Class: 459
 Situs: 8983 WEST STAYTON RD SE AUMSVILLE OR 97325 MaSaNh: 07 06 000 Unit: 28156 Year: 2025

Last Date Appraised: 01/13/2025 Appraiser: MATT LORD Retag: Y (N) Tag info: 2026 - Tags/Permit (Demolished)

Owner: STORMS, KEITH Roll Type: R

Cycle Tag Sales Verification Other: FARM check Inspection level: 1 2 (3) 4 LCB TTO INSP AV: 528282

RMV Land: 162460 RMV Imp: 505740 RMV Total: 668200 MAV: 21470 MSAV: 22542 SAV: 41398

Comment: 25-26: L3 MDL 1.13.25 TAG
 24-25 L4 3.28.24 MDL
 24-25 L4 2.7.24 MDL

*✓ For mobile Removal / AS OF 4/24/25 still on property /
 ✓ HAYING / live stock / 2-3 cows*

Notations 25-26: 2-3 cows 1/1/25 New House

RP/MS	Code	Description
MS	ZONED	FARM EFU ZONED
MS	ZONED	FARM EFU ZONED
MS	ZONED	FARM EFU ZONED

OSDs

Count	Code	Description	RMV	Code Area	Exception
1	SAF	SA OSD - FAIR ✓	40000	05555	0

Land

Site: 2	Code Area: 05555	Size: 1.00 Acres	Use Code: 005	Zone: REST	SAV Use: 011	Exception: 0
Class: 4BDS	Value Source: Farm Homesite	Description: FOUR BENCH DRY SPECIAL SOUTH		RMV: 23550	Exception: Y N	
Adjustment(s): IRR		Fire Patrol:		Description:		
Comments: Liability year - 2009 24-25: Update land classes						

Site: 3	Code Area: 05555	Size: 4.00 Acres	Use Code: 005	Zone: REST	SAV Use: 011	Exception: 0
Class: 4BISS	Value Source: Farm Use - EFU	Description: FOUR BENCH IRR SPECIAL SOUTH		RMV: 98910	Exception: Y N	
Adjustment(s): IRR		Fire Patrol:		Description:		
Comments: Liability year - 1982 25-26: Land classes ok						

Improvements - Residence / Manufactured Structures

Bldg: 1	Code Area: 05555	Stat Class: 444	Year Blt: 1975	Eff Year Blt: 1975	Sq.Ft: 1164	% Complete: 100
Desc: MANUF STRUCT, CLASS 4, 14' WIDE SINGLE			Dimensions: 66x14		RMV: 0	
Func Obsc: 100	Econ %: 100	Other %: 100	Exception: 0	Adjust:	Adjust RMV: 0	

Floors

Type	Class	Display Group	Floor Size	Beds	Baths	Yr Blt	Eff Yr Blt	Inventory	Exception
First Floor	4	Finished	1164	3	FB-1/ HB-1	1975	1975	ROOF, HVAC, SKIRT, KIT-, BTH - 1, BATH - 1	Y N

Accessories

Description	Class	Size SqFt	Eff Yr Blt	RMV	Quantity
No accessory data available					

Bldg: 2	Code Area: 05555	Stat Class: 141	Year Blt: 2024	Eff Year Blt: 2024	Sq.Ft: 2658	% Complete: 100
Desc: One Story Only			Dimensions:		RMV: 495500	
Func Obsc: 100	Econ %: 100	Other %: 100	Exception: 495500	Adjust:	Adjust RMV: 0	

Floors

Type	Class	Display Group	Floor Size	Beds	Baths	Yr Blt	Eff Yr Blt	Inventory	Exception
First Floor	4	Finished	2658	3	FB-2/ HB-1	2024	2024	HVAC, KIT, ROOF, BATH - 2, BTH - 1, FP - 1	Y N
Garage Attached	4	Finished	816	0	0	2024	2024	ROOF	Y N

Accessories

Description	Class	Size SqFt	Eff Yr Blt	RMV	Quantity
YARD IMPROVEMENTS AVERAGE	4	0	2024	32100	1
Exception: Y N					

Improvements - Accessory Buildings

Bldg: 1	Code Area: 05555	Stat Class: 351	Year Blt: 1992	Eff Year Blt: 1992	Sq.Ft: 1920	% Complete: 100
Desc: General Purpose Building (GB)			Dimensions: 60x32		RMV: 10240	
Func Obsc: 100	Econ %: 100	Other %: 100	Exception: 0	Adjust:	Adjust RMV: 0	

Floors

Type	Class	Display Group	Floor Size	Beds	Baths	Yr Blt	Eff Yr Blt	Inventory	Exception: Y N
General Purpose Bldg	4	Finished	1920	0	0	1992	1992	FAIR ✓	

Accessories

Description	Class	Size SqFt	Eff Yr Blt	RMV	Quantity
No accessory data available					

SKETCH/AREA TABLE ADDENDUM

SUBJECT INFO

File No.: 535034 Parcel No.: 092W01B 00100
 Property Address: 8983 West Stayton Rd SE
 City: Aumsville County: Marion State: OR ZipCode: 97325
 Owner:
 Client: Client Address:
 Appraiser Name: Inspection Date:

SKETCH

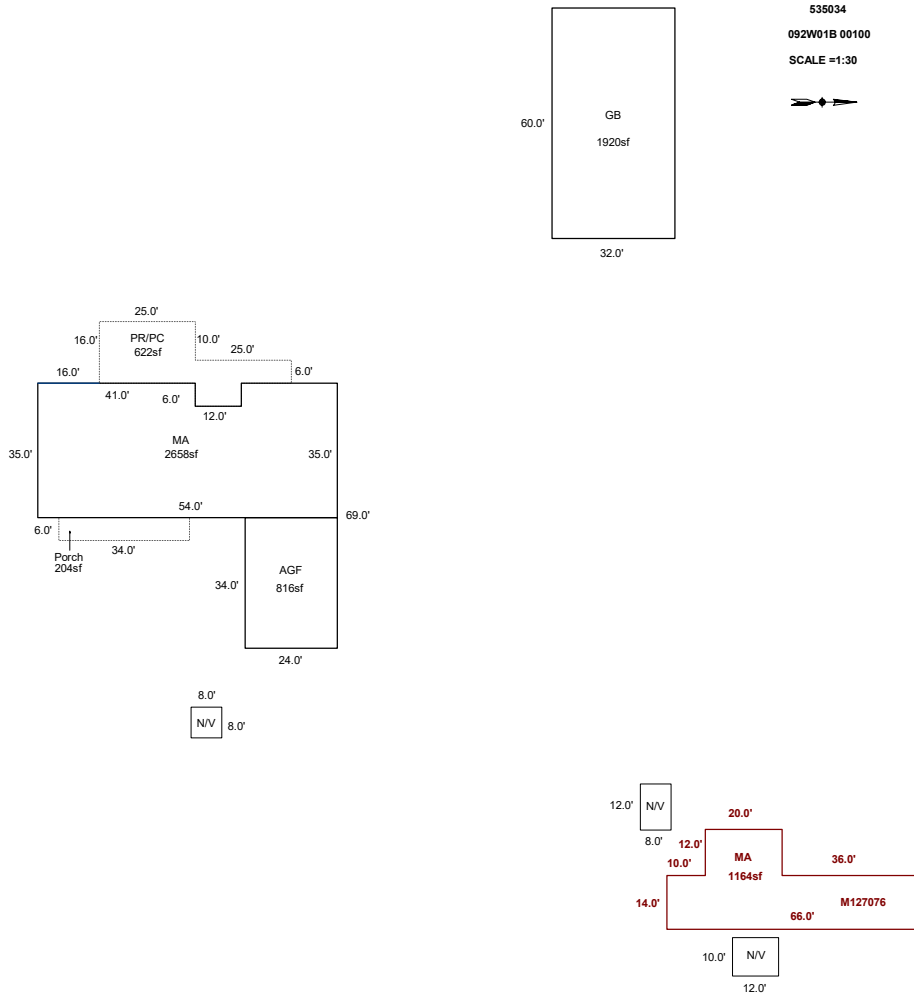

Sketch by ApexSketch

AREA CALCULATIONS SUMMARY

Code	Description	Factor	Net Size	Perimeter	Net Totals
GBA1	GB	1.0	1920.0	184.0	1920.0
GLA1	MA	1.0	1164.0	184.0	
	MA	1.0	2658.0	238.0	3822.0
GAR	AGF	1.0	816.0	116.0	816.0
P/P	Porch	1.0	204.0	80.0	
	PR/PC	1.0	622.0	144.0	826.0

COMMENT TABLE 1

Apex by RW 05/29/08
 UPDATED BY JRONDEMA 11/2/16
 UPDATED BY WWILLIAMS 4/11/24
 UPDATED BY CLOBERG 07/08/2024 24-003422 MA
 UPDATED BY CLOBERG 01/30/25

COMMENT TABLE 2

#36 DB 10/14/16
 JJS 2.7.24
 MDL 01/13/25

COMMENT TABLE 3

TAGS L4
 TAGS L2

Net LIVABLE	cnt	0	(rounded)	3,822
Net BUILDING	cnt	1	(rounded)	1,920







Acct ID: 535034 MTL: 092W01B000100 Date: 1/13/25 Appr: MNL Prop Class: 559 RMV Prop Class: 459
 Situs: 8983 WEST STAYTON RD SE AUMSVILLE OR 97325 MaSaNh: 07 06 000 Unit: 28156 Year: ~~2024~~ 2025
 Last Date Appraised: 03/28/2024 Appraiser: MATT LORD Retag: Y (N) Tag info: 2025 - NEW RESIDENCE (Residence)
 Owner: STORMS, KEITH Roll Type: R
 Cycle (Tag) Sales Verification Other: _____ Inspection level: 1 (2) 3 4 LCB TTO INSP AV: 45430
 RMV Land: 135510 RMV Imp: 40630 RMV Total: 176140 MAV: 23420 MSAV: 22010 SAV: 38746
 Comment: 24-25 L4 3.28.24 MDL 24-003422
 24-25 L4 2.7.24 MDL

Chris 2/20/25

25-26: New SFD/RePlace MFH 100% complete

RP/MS	Code	Description
MS	ZONED	FARM EFU ZONED
MS	ZONED	FARM EFU ZONED
MS	ZONED	FARM EFU ZONED

OSDs

Count	Code	Description	RMV	Code Area	Exception
1	SAF	SA OSD - FAIR	35000	05555	0

Land

Site: 2	Code Area: 05555	Size: 1.00 Acres	Use Code: 005	Zone: REST	SAV Use: 011	Exception: 0
Class: 4BDS S	Value Source: Farm Homesite	Description: FOUR BENCH DRY SPECIAL SOUTH	RMV: 20100	Exception: Y	N	
Adjustment(s):		Fire Patrol:	Description:			
Comments: Liability year - 2009	24-25: Update land classes					
Site: 3	Code Area: 05555	Size: 4.00 Acres	Use Code: 005	Zone: REST	SAV Use: 011	Exception: 0
Class: 4BISS	Value Source: Farm Use - <u>EFU</u>	Description: FOUR BENCH IRR SPECIAL SOUTH	RMV: 80410	Exception: Y	N	
Adjustment(s):		Fire Patrol:	Description:			
Comments: Liability year - 1982 / 550050						

Improvements - Residence / Manufactured Structures

Bldg: 1	Code Area: 05555	Stat Class: 444	Year Blt: 1975	Eff Year Blt: 1975	Sq.Ft: 1164	% Complete: 100
Desc: MANUF STRUCT, CLASS 4, 14' WIDE SINGLE	Dimensions: 66x14	RMV: 26590				
Func Obsc: 100	Econ %: 100	Other %: 100	Exception: 0	Adjust:	Adjust RMV: 0	

Floors

Type	Class	Display Group	Floor Size	Beds	Baths	Yr Blt	Eff Yr Blt	Inventory	Exception
First Floor	4	Finished	1164	3	FB-1/ HB-1	1975	1975	BATH - 1, BTH - 1, KIT-, SKIRT, HVAC, ROOF	Y N

Accessories

In Process of Being Demord / Hope to be gone by MAY

Description	Class	Size SqFt	Eff Yr Blt	RMV	Quantity
No accessory data available					

Improvements - Accessory Buildings

Bldg: 1	Code Area: 05555	Stat Class: 351	Year Blt: 1992	Eff Year Blt: 1992	Sq.Ft: 1920	% Complete: 100
Desc: General Purpose Building (GB)	Dimensions: 60x32	RMV: 10810				
Func Obsc: 100	Econ %: 100	Other %: 100	Exception: 0	Adjust:	Adjust RMV: 0	

Floors

Type	Class	Display Group	Floor Size	Beds	Baths	Yr Blt	Eff Yr Blt	Inventory	Exception
General Purpose Bldg	4	Finished	1920	0	0	1992	1992	FAIR ✓	Y N

Accessories

Description	Class	Size SqFt	Eff Yr Blt	RMV	Quantity
No accessory data available					

Bldg: 2	Code Area: 05555	Stat Class: 341	Year Blt: 1986	Eff Year Blt: 1986	Sq.Ft: 432	% Complete: 100
Desc: Multi Purpose Shed (MP)	Dimensions: 24x18	RMV: 2220				
Func Obsc: 100	Econ %: 100	Other %: 100	Exception: 0	Adjust:	Adjust RMV: 0	

Floors

Type	Class	Display Group	Floor Size	Beds	Baths	Yr Blt	Eff Yr Blt	Inventory	Exception
Multi-Purpose Bldg	4	Finished	432	0	0	1986	1986	FAIR	Y N

Accessories

Description	Class	Size SqFt	Eff Yr Blt	RMV	Quantity
No accessory data available					

Bldg: 3 Code Area: 05555 Stat Class: 355 Year Blt: 1986 Eff Year Blt: 1986 Sq.Ft: 576 % Complete: 100
 Desc: Lean-to Heavy (LTH) Dimensions: 36x16 RMV: 1010
 Func Obsc: 100 Econ %: 100 Other %: 100 Exception: 0 Adjust: Adjust RMV: 0

Floors

Type	Class	Display Group	Floor Size	Beds	Baths	Yr Blt	Eff Yr Blt	Inventory
Lean-to Heavy Duty	4	Finished	576	0	0	1986	1986	Exception: Y N

Accessories

Description	Class	Size SqFt	Eff Yr Blt	RMV	Quantity
No accessory data available					

ACCOUNT # 535034 DATE: _____ RMV CLASS _____ PROP CLASS _____
 MTL _____ APPR MISL TAG Y N _____
 COMMENTS: _____

RESIDENCE / MANUFACTURED STRUCTURES

ACCESSORY IMPROVEMENTS / OUTBUILDINGS

STAT 141 QLTY + - FLOOR MA
 AREA 2658 EFF AREA 2658 BED 3
 ROOF + AVL HVAC +
 2.5 BATH PKG: 2 BATH _____ BATH + 1 1/2 BTH
 FIREPLACE: 1
 KITCHEN - +
 YR BLT 2024 EFF YR 2024 ECON _____
 % COMP 100 % GOOD _____ FUNC _____
 EXCEPT Y N LUMP SUM: _____
 MISC: _____
 YI CLASS _____ F G A E
 SKIRT + LIN FT _____
 COMMENT: _____

TYPE ABF
 STAT / CLASS 141
 SIZE 816
 FAIR
AVERAGE Roof
 GOOD
 EXCELLENT
 BATH _____
 YR BLT 2024
 EFF YR 2024
 % COMP 100
 EXCEPT Y N
 MISC: _____
 COMMENT: _____

TYPE _____
 STAT / CLASS _____
 SIZE _____
 FAIR
 AVERAGE
 GOOD
 EXCELLENT
 BATH _____
 YR BLT _____
 EFF YR _____
 % COMP _____
 EXCEPT Y N
 MISC: _____
 COMMENT: _____

STAT _____ QLTY + - FLOOR _____
 AREA _____ EFF AREA _____ BED _____
 ROOF + HVAC +
 BATH PKG: _____ BATH _____ BATH + _____ 1/2 BTH
 FIREPLACE: _____
 KITCHEN - +
 YR BLT _____ EFF YR _____ ECON _____
 % COMP _____ % GOOD _____ FUNC _____
 EXCEPT Y N LUMP SUM: _____
 MISC: _____
 YI CLASS _____ F G A E
 SKIRT + LIN FT _____
 COMMENT: _____

TYPE _____
 STAT / CLASS _____
 SIZE _____
 FAIR
 AVERAGE
 GOOD
 EXCELLENT
 BATH _____
 YR BLT _____
 EFF YR _____
 % COMP _____
 EXCEPT Y N
 MISC: _____
 COMMENT: _____

TYPE _____
 STAT / CLASS _____
 SIZE _____
 FAIR
 AVERAGE
 GOOD
 EXCELLENT
 BATH _____
 YR BLT _____
 EFF YR _____
 % COMP _____
 EXCEPT Y N
 MISC: _____
 COMMENT: _____

STAT _____ QLTY + - FLOOR _____
 AREA _____ EFF AREA _____ BED _____
 ROOF + HVAC +
 BATH PKG: _____ BATH _____ BATH + _____ 1/2 BTH
 FIREPLACE: _____
 KITCHEN - +
 YR BLT _____ EFF YR _____ ECON _____
 % COMP _____ % GOOD _____ FUNC _____
 EXCEPT Y N LUMP SUM: _____
 MISC: _____
 YI CLASS _____ F G A E
 SKIRT + LIN FT _____
 COMMENT: _____

TYPE _____
 STAT / CLASS _____
 SIZE _____
 FAIR
 AVERAGE
 GOOD
 EXCELLENT
 BATH _____
 YR BLT _____
 EFF YR _____
 % COMP _____
 EXCEPT Y N
 MISC: _____
 COMMENT: _____

TYPE _____
 STAT / CLASS _____
 SIZE _____
 FAIR
 AVERAGE
 GOOD
 EXCELLENT
 BATH _____
 YR BLT _____
 EFF YR _____
 % COMP _____
 EXCEPT Y N
 MISC: _____
 COMMENT: _____



1/13/25

Acct ID: 535034 MTL: 092W01B000100 Date: 1/13/25 Appr: MNL Prop Class: 559 RMV Prop Class: 459
 Situs: 8983 WEST STAYTON RD SE AUMSVILLE OR 97325 MaSaNh: 07 06 000 Unit: 28156 Year: ~~2024~~ 2025
 Last Date Appraised: 03/28/2024 Appraiser: MATT LORD Retag: Y (N) Tag info: 2025 - NEW RESIDENCE (Residence)
 Owner: STORMS, KEITH Roll Type: R
 Cycle (Tag) Sales Verification Other: _____ Inspection level: 1 (2) 3 4 LCB TTO INSP AV: 45430
 RMV Land: 135510 RMV Imp: 40630 RMV Total: 176140 MAV: 23420 MSAV: 22010 SAV: 38746
 Comment: 24-25 L4 3.28.24 MDL 24-003422
 24-25 L4 2.7.24 MDL

Chris 2/20/25

25-26: New SFD/RePlace MFH 100% complete

RP/MS	Code	Description
MS	ZONED	FARM EFU ZONED
MS	ZONED	FARM EFU ZONED
MS	ZONED	FARM EFU ZONED

OSDs

Count	Code	Description	RMV	Code Area	Exception
1	SAF	SA OSD - FAIR	35000	05555	0

Land

Site: 2	Code Area: 05555	Size: 1.00 Acres	Use Code: 005	Zone: REST	SAV Use: 011	Exception: 0
Class: 4BDS S	Value Source: Farm Homesite	Description: FOUR BENCH DRY SPECIAL SOUTH	RMV: 20100	Exception: Y	N	
Adjustment(s):	Fire Patrol:	Description:				
Comments: Liability year - 2009	24-25: Update land classes					
Site: 3	Code Area: 05555	Size: 4.00 Acres	Use Code: 005	Zone: REST	SAV Use: 011	Exception: 0
Class: 4BISS	Value Source: Farm Use - <u>EFU</u>	Description: FOUR BENCH IRR SPECIAL SOUTH	RMV: 80410	Exception: Y	N	
Adjustment(s):	Fire Patrol:	Description:				
Comments: Liability year - 1982 / 550050						

Improvements - Residence / Manufactured Structures

Bldg: 1	Code Area: 05555	Stat Class: 444	Year Blt: 1975	Eff Year Blt: 1975	Sq.Ft: 1164	% Complete: 100
Desc: MANUF STRUCT, CLASS 4, 14' WIDE SINGLE	Dimensions: 66x14	RMV: 26590				
Func Obsc: 100	Econ %: 100	Other %: 100	Exception: 0	Adjust:	Adjust RMV: 0	

Floors

Type	Class	Display Group	Floor Size	Beds	Baths	Yr Blt	Eff Yr Blt	Inventory	Exception
First Floor	4	Finished	1164	3	FB-1/ HB-1	1975	1975	BATH - 1, BTH - 1, KIT-, SKIRT, HVAC, ROOF	Y N

Accessories

In process of being Demord / Hope to be gone by MAY

Description	Class	Size SqFt	Eff Yr Blt	RMV	Quantity
No accessory data available					

Improvements - Accessory Buildings

Bldg: 1	Code Area: 05555	Stat Class: 351	Year Blt: 1992	Eff Year Blt: 1992	Sq.Ft: 1920	% Complete: 100
Desc: General Purpose Building (GB)	Dimensions: 60x32	RMV: 10810				
Func Obsc: 100	Econ %: 100	Other %: 100	Exception: 0	Adjust:	Adjust RMV: 0	

Floors

Type	Class	Display Group	Floor Size	Beds	Baths	Yr Blt	Eff Yr Blt	Inventory	Exception
General Purpose Bldg	4	Finished	1920	0	0	1992	1992	FAIR ✓	Y N

Accessories

Description	Class	Size SqFt	Eff Yr Blt	RMV	Quantity
No accessory data available					

Bldg: 2	Code Area: 05555	Stat Class: 341	Year Blt: 1986	Eff Year Blt: 1986	Sq.Ft: 432	% Complete: 100
Desc: Multi Purpose Shed (MP)	Dimensions: 24x18	RMV: 2220				
Func Obsc: 100	Econ %: 100	Other %: 100	Exception: 0	Adjust:	Adjust RMV: 0	

Floors

Type	Class	Display Group	Floor Size	Beds	Baths	Yr Blt	Eff Yr Blt	Inventory	Exception
Multi-Purpose Bldg	4	Finished	432	0	0	1986	1986	FAIR	Y N

Accessories

Description	Class	Size SqFt	Eff Yr Blt	RMV	Quantity
No accessory data available					

Bldg: 3 Code Area: 05555 Stat Class: 355 Year Blt: 1986 Eff Year Blt: 1986 Sq.Ft: 576 % Complete: 100
 Desc: Lean-to Heavy (LTH) Dimensions: 36x16 RMV: 1010
 Func Obsc: 100 Econ %: 100 Other %: 100 Exception: 0 Adjust: Adjust RMV: 0

Floors

Type	Class	Display Group	Floor Size	Beds	Baths	Yr Blt	Eff Yr Blt	Inventory
Lean-to Heavy Duty	4	Finished	576	0	0	1986	1986	Exception: Y N

Accessories

Description	Class	Size SqFt	Eff Yr Blt	RMV	Quantity
No accessory data available					

ACCOUNT # 535034 DATE: _____ RMV CLASS _____ PROP CLASS _____
 MTL _____ APPR MISL TAG Y N _____
 COMMENTS: _____

RESIDENCE / MANUFACTURED STRUCTURES

ACCESSORY IMPROVEMENTS / OUTBUILDINGS

STAT 141 QLTY + - FLOOR MA
 AREA 2658 EFF AREA 2658 BED 3
 ROOF + AVL HVAC +
 2.5 BATH PKG: 2 BATH _____ BATH + 1 1/2 BTH
 FIREPLACE: 1
 KITCHEN - +
 YR BLT 2024 EFF YR 2024 ECON _____
 % COMP 100 % GOOD _____ FUNC _____
 EXCEPT Y N LUMP SUM: _____
 MISC: _____
 YI CLASS _____ F G A E
 SKIRT + LIN FT _____
 COMMENT: _____

TYPE ABF
 STAT / CLASS 141
 SIZE 816
 FAIR
AVERAGE Roof
 GOOD
 EXCELLENT
 BATH _____
 YR BLT 2024
 EFF YR 2024
 % COMP 100
 EXCEPT Y N
 MISC: _____
 COMMENT: _____

TYPE _____
 STAT / CLASS _____
 SIZE _____
 FAIR
 AVERAGE
 GOOD
 EXCELLENT
 BATH _____
 YR BLT _____
 EFF YR _____
 % COMP _____
 EXCEPT Y N
 MISC: _____
 COMMENT: _____

STAT _____ QLTY + - FLOOR _____
 AREA _____ EFF AREA _____ BED _____
 ROOF + HVAC +
 BATH PKG: _____ BATH _____ BATH + _____ 1/2 BTH
 FIREPLACE: _____
 KITCHEN - +
 YR BLT _____ EFF YR _____ ECON _____
 % COMP _____ % GOOD _____ FUNC _____
 EXCEPT Y N LUMP SUM: _____
 MISC: _____
 YI CLASS _____ F G A E
 SKIRT + LIN FT _____
 COMMENT: _____

TYPE _____
 STAT / CLASS _____
 SIZE _____
 FAIR
 AVERAGE
 GOOD
 EXCELLENT
 BATH _____
 YR BLT _____
 EFF YR _____
 % COMP _____
 EXCEPT Y N
 MISC: _____
 COMMENT: _____

TYPE _____
 STAT / CLASS _____
 SIZE _____
 FAIR
 AVERAGE
 GOOD
 EXCELLENT
 BATH _____
 YR BLT _____
 EFF YR _____
 % COMP _____
 EXCEPT Y N
 MISC: _____
 COMMENT: _____

STAT _____ QLTY + - FLOOR _____
 AREA _____ EFF AREA _____ BED _____
 ROOF + HVAC +
 BATH PKG: _____ BATH _____ BATH + _____ 1/2 BTH
 FIREPLACE: _____
 KITCHEN - +
 YR BLT _____ EFF YR _____ ECON _____
 % COMP _____ % GOOD _____ FUNC _____
 EXCEPT Y N LUMP SUM: _____
 MISC: _____
 YI CLASS _____ F G A E
 SKIRT + LIN FT _____
 COMMENT: _____

TYPE _____
 STAT / CLASS _____
 SIZE _____
 FAIR
 AVERAGE
 GOOD
 EXCELLENT
 BATH _____
 YR BLT _____
 EFF YR _____
 % COMP _____
 EXCEPT Y N
 MISC: _____
 COMMENT: _____

TYPE _____
 STAT / CLASS _____
 SIZE _____
 FAIR
 AVERAGE
 GOOD
 EXCELLENT
 BATH _____
 YR BLT _____
 EFF YR _____
 % COMP _____
 EXCEPT Y N
 MISC: _____
 COMMENT: _____

SKETCH/AREA TABLE ADDENDUM

SUBJECT INFO

File No.: 535034 Parcel No.: 092W01B 00100
 Property Address: 8983 West Stayton Rd SE
 City: Aumsville County: Marion State: OR ZipCode: 97325
 Owner:
 Client: Client Address:
 Appraiser Name: Inspection Date:

SKETCH

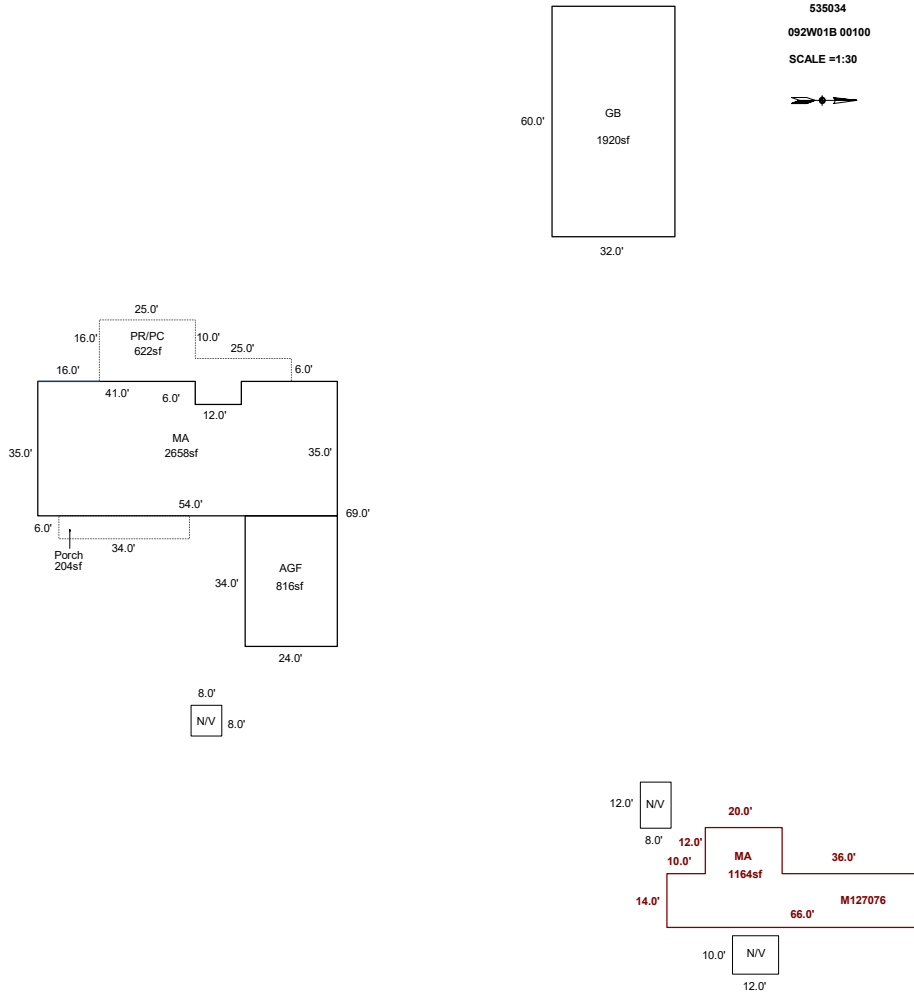

Sketch by ApexSketch

AREA CALCULATIONS SUMMARY

Code	Description	Factor	Net Size	Perimeter	Net Totals
GBA1	GB	1.0	1920.0	184.0	1920.0
GLA1	MA	1.0	1164.0	184.0	
	MA	1.0	2658.0	238.0	3822.0
GAR	AGF	1.0	816.0	116.0	816.0
P/P	Porch	1.0	204.0	80.0	
	PR/PC	1.0	622.0	144.0	826.0

COMMENT TABLE 1

Apex by RW 05/29/08
 UPDATED BY JRONDEMA 11/2/16
 UPDATED BY WWILLIAMS 4/11/24
 UPDATED BY CLOBERG 07/08/2024 24-003422 MA
 UPDATED BY CLOBERG 01/30/25

COMMENT TABLE 2

#36 DB 10/14/16
 JJS 2.7.24
 MDL 01/13/25

COMMENT TABLE 3

TAGS L4
 TAGS L2

Net LIVABLE	cnt	0	(rounded)		3,822
Net BUILDING	cnt	1	(rounded)		1,920

SKETCH/AREA TABLE ADDENDUM

SUBJECT INFO

File No.: 535034 Parcel No.: 092W01B 00100
 Property Address: 8983 West Stayton Rd SE
 City: Aumsville County: Marion State: OR ZipCode: 97325
 Owner:
 Client: Client Address:
 Appraiser Name: Inspection Date:

SKETCH

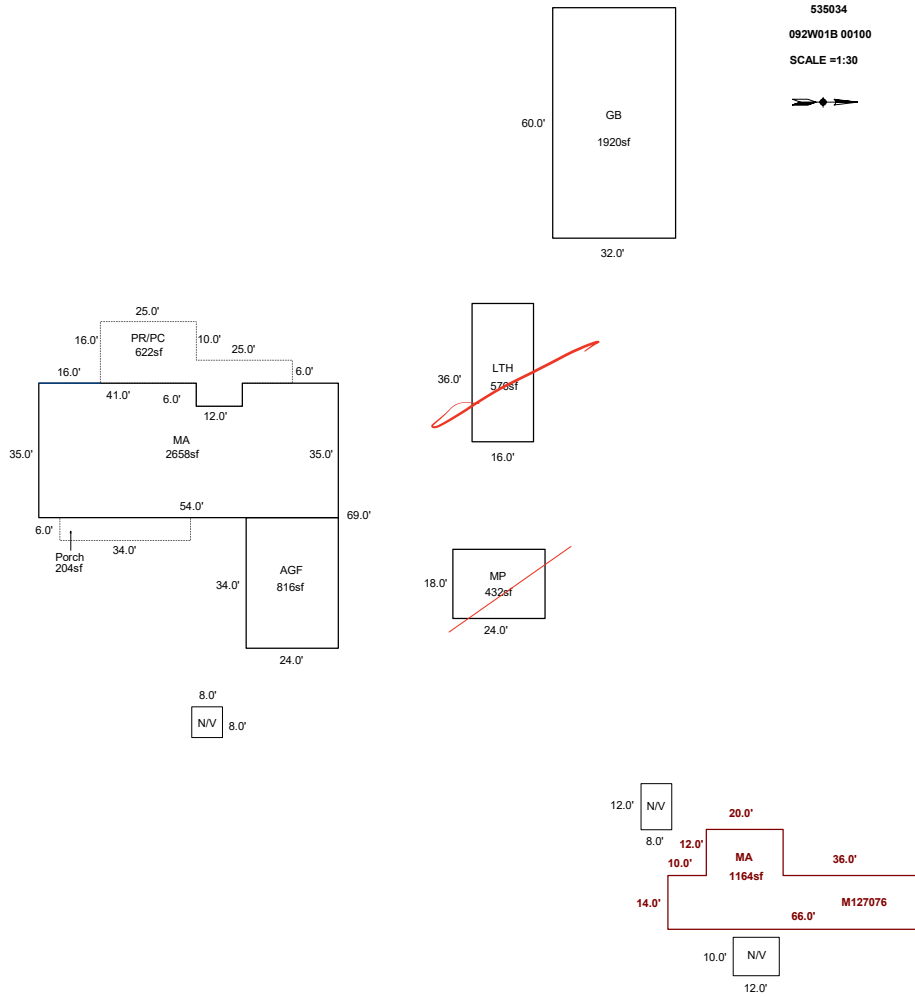

AREA CALCULATIONS SUMMARY

Code	Description	Factor	Net Size	Perimeter	Net Totals
GBA1	GB	1.0	1920.0	184.0	
	MP	1.0	432.0	84.0	
	LTH	1.0	576.0	104.0	2928.0
GLA1	MA	1.0	1164.0	184.0	
	MA	1.0	2658.0	238.0	3822.0
GAR	AGF	1.0	816.0	116.0	816.0
P/P	Porch	1.0	204.0	80.0	
	PR/PC	1.0	622.0	144.0	826.0

COMMENT TABLE 1

Apex by RW 05/29/08
 UPDATED BY JRONDEMA 11/2/16
 UPDATED BY WWILLIAMS 4/11/24
 UPDATED BY CLOBERG 07/08/2024 24-003422 MA

COMMENT TABLE 2

#36 DB 10/14/16
 JJS 2.7.24

COMMENT TABLE 3

TAGS L4

Net LIVABLE	cnt	2	(rounded)	3,822
Net BUILDING	cnt	3	(rounded)	2,928



1/13/25

SKETCH/AREA TABLE ADDENDUM

SUBJECT INFO

File No.: R35034 Parcel No.: 092W01B 00100
 Property Address: 8983 West Stayton Rd SE
 City: Aumsville County: State: OR ZipCode: 97325
 Owner:
 Client: Client Address:
 Appraiser Name: Inspection Date:

SKETCH

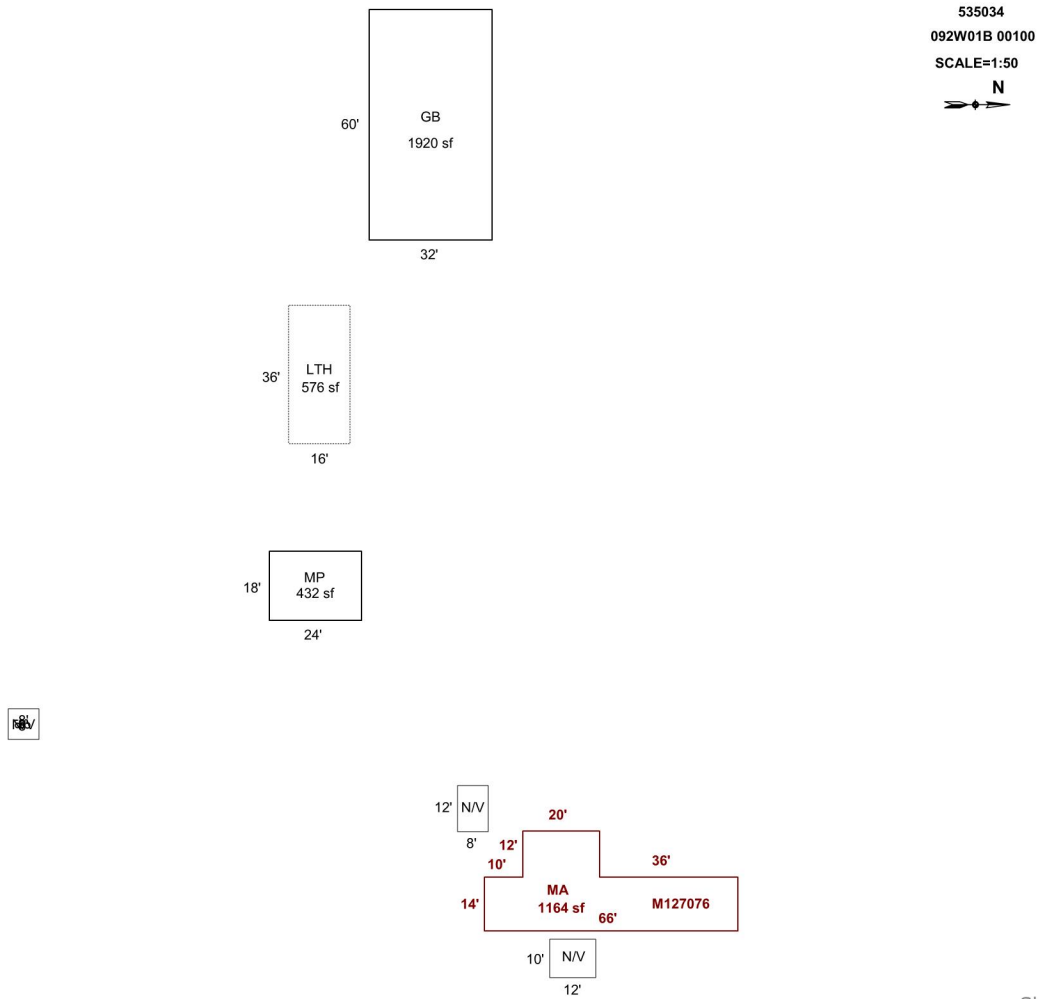

Sketch by ApexSketch

AREA CALCULATIONS SUMMARY

Code	Description	Factor	Net Size	Perimeter	Net Totals
GBA1	GB	1.0	1920.0	184.0	
	MP	1.0	432.0	84.0	
	LTH	1.0	576.0	104.0	2928.0
GLA1	MA	1.0	1164.0	184.0	1164.0

COMMENT TABLE 1

Apex by RW 05/29/08
 UPDATED BY JRONDEMA 11/2/16
 UPDATED BY WWILLIAMS 4/11/24

COMMENT TABLE 2

#36 DB 10/14/16
 JJS 2.7.24

COMMENT TABLE 3

TAGS L4

Net LIVABLE	cnt	1	(rounded)		1,164
Net BUILDING	cnt	3	(rounded)		2,928

R35034
 092W01B 00100
 SCALE=1:50
 N

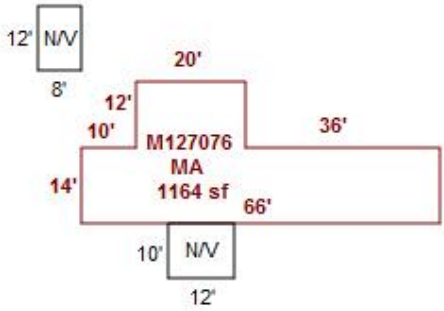
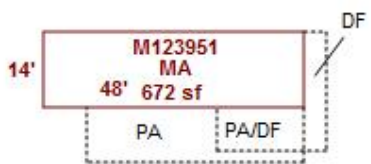
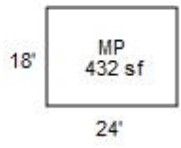
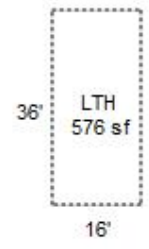
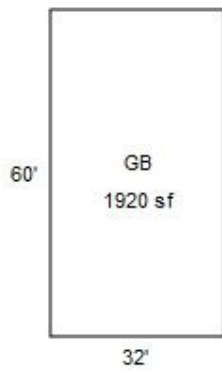

092W01B 00100

M127076

01D T44C

00550050

00550050

COOK,ARNOLD B & DONNA M

0.0000 Acres

8983 W STAYTON RD SE

2/8/02

M127076 092W01B 00100 Appr #: 36 Date 10/14/16 Prop Class 049 Prop Code T44
 Situs Address 8983 WEST STAYTON RD SE Franchise Code 36 Year For: **2016-2017**
 Owner COOK,ARNOLD B & 17-18

Notes: No change Tags Cycle Sales Verification Other: _____

RMV Imp: 15,030 RMV Total: 15,030 M50 Total: 8,040

Seg.Type MA Seg. # 1.1 Method M04 Class 4S Area 1164 Eff Area 1164 Length 66 Width 14
 Make: Model: STATLER Intfinish: PANEL Roof Cover METAL
 Plumbing BATH1.5 Heat: FA Fireplace: Inter. Comp: Bedrooms: 3
 Year Built 1975 Eff.Year Built 1975 Cond. P F A G E
 Adj Codes MSLCMS Qty _____ % Comp _____ Func _____ Econ _____ RMV 14,720
 Lump Sum _____ Except Code/Year _____ Comments _____

Accessory Improvements

Out Buildings and Skirting

Seg.Type MHSK MFD STRUCT Seg. # 1.2 Method: M04 Class Area 184 Eff Area 184
 Length Width Foundation Ex. Wall METAL Roof Cover
 Roof Style Floor Plumbing
 Heat Int. Comp. Elect. Yr. Blt. Eff. Yr. Blt: 1975
 Cond. P F A G E Adj. Codes % Comp _____ Func _____ Econ _____ RMV: 310
 Lump Sum _____ Except Code/Year _____ Comments _____

M127076 092W01B 00100 Appr #: 36 Date 10/14/16 Prop Class 049 Prop Code T44
 Situs Address 8983 WEST STAYTON RD SE Franchise Code 36 Year For: ~~2016-2017~~
 Owner COOK,ARNOLD B & 17-18

Tags Cycle Sales Verification Other: _____

Notes: _____
 RMV Imp: 15,030 RMV Total: 15,030 M50 Total: 8,040

Segment							Land
Class							
Dim/Size							
Foundation							
Exter Wall							
Wall Height							
Inter Finish							
Roof Cover							
Roof Style							
Flooring							
Plumbing							
Electric							
Misc.							
Yr Blt							
Eff Yr							
Cond.							
% Good							
% Comp							
Lump Sum							
Except.Code							

Land Segments

Seg. No Description Schedule Acres Adjustment Codes Exception Code

Eff Acres Companion Accounts R35034 092W01B 00100

Date 11-8-16 Clerk JS **ROUTING SLIP**

Work Needed: (Please make necessary comments, sign and pass to the next appropriate person.)

Data entry reviewed by/comments _____

Appraiser response _____

BUILDING DIAGRAM AND OUTBUILDINGS

ACCT. NO.

61385-000

MAP NO.

1-9-ZW

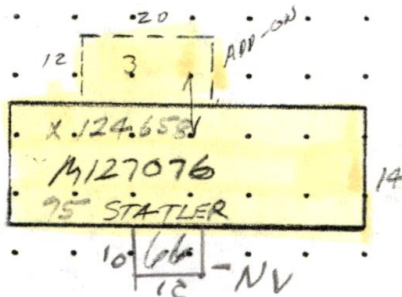
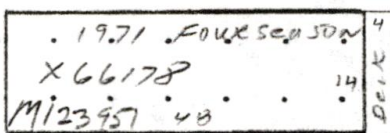
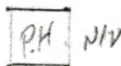
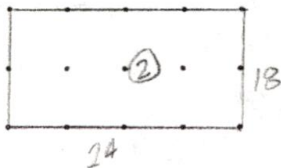
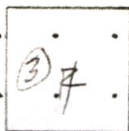

Hardship

These Imp. valued with MH

8983 W STAYTON RD SE

MEASUREMENT VERIFIED

REMARKS:

Both MH sharing same Septic & well

MH X 66178 move in 1986

DATE

BY

4-14-87

REYES

1-7-92
10/14/16

KEN #32 VER
#36

CLM1 = 924
ZON12 = 240

