

SKETCH/AREA TABLE ADDENDUM

SUBJECT INFO

File No.: 328439 Parcel No.: 063W35CC01801
 Property Address: 278 SANDY DR N
 City: KEIZER County: State: OR ZipCode: 97303
 Owner:
 Client: Client Address:
 Appraiser Name: Inspection Date:

SKETCH

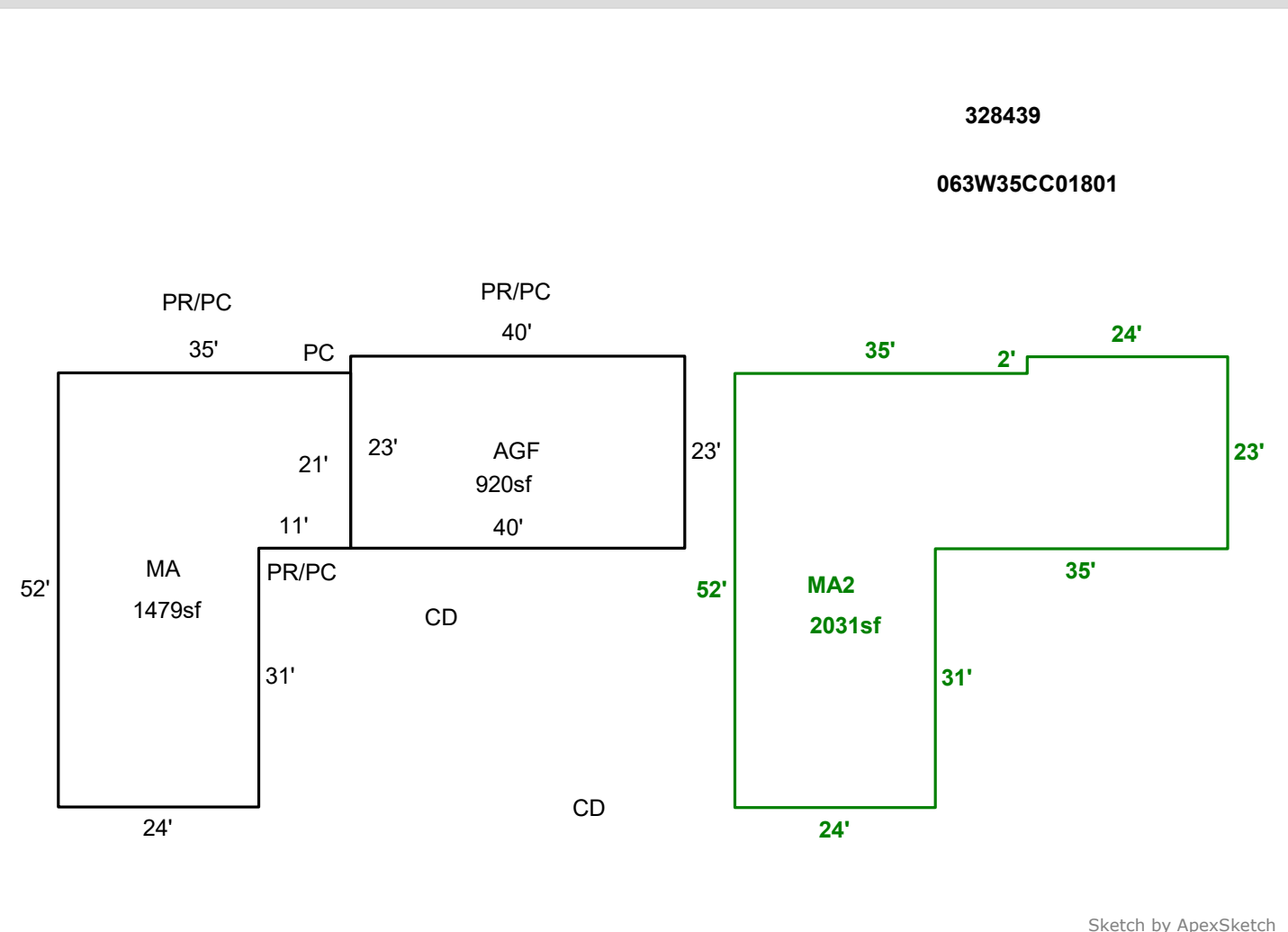

Sketch by ApexSketch

AREA CALCULATIONS SUMMARY					
Code	Description	Factor	Net Size	Perimeter	Net Totals
GLA1	MA	1.0	1479.0	174.0	1479.0
GLA2	MA2	1.0	2031.0	226.0	2031.0
GARAGE	AGF	1.0	920.0	126.0	920.0
Net LIVABLE		cnt	1 (rounded)		3,510

COMMENT TABLE 1	
DRAWN BY TJS 12-28-11 UPDATED BY LK 8.27.25	
COMMENT TABLE 2	COMMENT TABLE 3
8.4.25 CYCLE SH	