

SKETCH/AREA TABLE ADDENDUM

SUBJECT INFO

File No.: 332548 Parcel No.: 083W08C 03203
 Property Address: 2975 MARTINSON LN S
 City: SALEM County: MARION State: OR ZipCode: 97302
 Owner:
 Client: Client Address:
 Appraiser Name: Inspection Date:

SKETCH

↑
POND
~500'

332548
083W08C 03203
SCALE = 1:30
↔

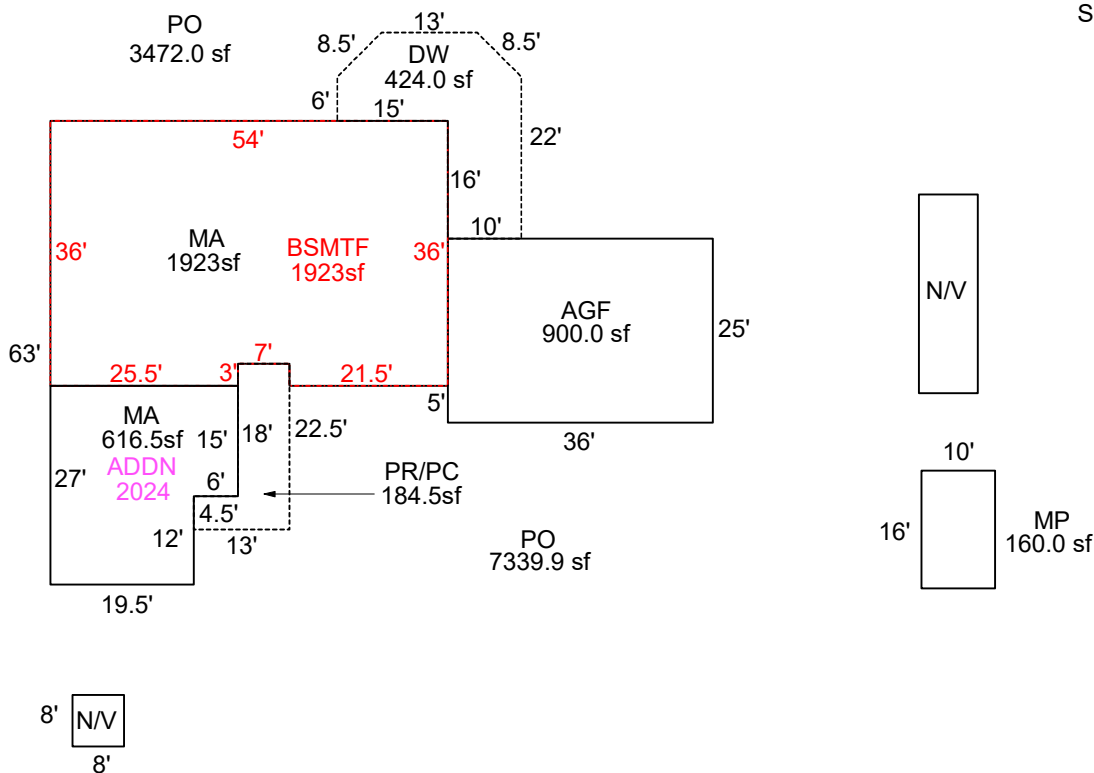

Sketch by ApexSketch

AREA CALCULATIONS SUMMARY

Code	Description	Factor	Net Size	Perimeter	Net Totals
GBA1	MP	1.0	160.0	52.0	160.0
GLA0	BSMTF	1.0	1923.0	186.0	1923.0
GLA1	MA	1.0	1923.0	186.0	
	MA	1.0	616.5	105.0	2539.5
GAR	AGF	1.0	900.0	122.0	900.0
P/P	PR/PC	1.0	184.5	71.0	184.5

COMMENT TABLE 1

DRAWN BY BB44
 UPDATED BY CJURAN 03/12/2024 24-000526 ADDN
 UPDATED BY CLOBERG 09/19/25 25-005328 CONV

COMMENT TABLE 2

COMMENT TABLE 3

Net LIVABLE cnt 0 (rounded) 4,463
 Net BUILDING cnt 1 (rounded) 160