

Acct ID: 530380 MTL: 082W24B002000 Date: 7/3/25 Appr: MDL Prop Class: 409 RMV Prop Class: 409
 Situs: 8555 AUMSVILLE HWY SE SALEM OR 97317 MaSaNh: 07 06 000 Unit: 49611 Year: 2025

Last Date Appraised: 09/26/2014 Appraiser: MATT LORD Retag: Y (N) Tag info:
 Owner: CLARK, JIMMIE W & CLARK, SOM PHONG Roll Type: R
 Cycle Tag Sales Verification Other: _____ Inspection level: 1 2 (3) 4 LCB TTO INSP AV: 193580
 RMV Land: 324670 RMV Imp: 132810 RMV Total: 457480 MAV: 193580 MSAV: 0 SAV: 0
 Comment: BATED

Notations 25-26 cycle
 No notation data available.

OSDs

Count	Code	Description	RMV	Code Area	Exception
1	MKTA	OSD - AVERAGE	50000	05558	0

Land

Site: 1 Code Area: 05558 Size: 5.00 Acres Use Code: 004 Zone: NREST SAV Use: Exception: 0
 Class: 4BDS Value Source: Rural at MKT Description: RMV: 274670 Exception: Y N
 Adjustment(s): Fire Patrol: Description:
 Comments: 2002-03 REAPPRAISAL.

Improvements - Residence / Manufactured Structures

Bldg: 1 Code Area: 05558 Stat Class: 457 Year Blt: 1991 Eff Year Blt: 1991 Sq.Ft: 1404 % Complete: 100
 Desc: MANUF STRUCT, CLASS 5, 26' THROUGH 28' WIDE DOUBLE Dimensions: 52x27 RMV: 49330
 Func Obsc: 100 Econ %: 100 Other %: 100 Exception: 0 Adjust: Adjust RMV: 0

Floors

Type	Class	Display Group	Floor Size	Beds	Baths	Yr Blt	Eff Yr Blt	Inventory	Exception
First Floor	5	Finished	1404	3	FB-2	1991	1991	BATH - 2, KIT-, HVAC+, ROOF, SKIRT	Y N

Accessories

Description	Class	Size SqFt	Eff Yr Blt	RMV	Quantity
No accessory data available					

Bldg: 1 Code Area: 05558 Stat Class: 148 Year Blt: 1981 Eff Year Blt: 1981 Sq.Ft: 0 % Complete: 100
 Desc: Res other improvements Dimensions: RMV: 75110
 Func Obsc: 100 Econ %: 100 Other %: 100 Exception: 0 Adjust: Adjust RMV: 0

Floors

Type	Class	Display Group	Floor Size	Beds	Baths	Yr Blt	Eff Yr Blt	Inventory	Exception
Garage Detached	4	Unfinished	768	0	0	1981	1981	ROOF	Y N

Accessories

Description	Class	Size SqFt	Eff Yr Blt	RMV	Quantity
YARD IMPROVEMENTS AVERAGE ✓	3	1	1981	15215	1
Exception: Y N					

Improvements - Accessory Buildings

Bldg: 2 Code Area: 05558 Stat Class: 351 Year Blt: 1993 Eff Year Blt: 1993 Sq.Ft: 1440 % Complete: 100
 Desc: General Purpose Building (GB) Dimensions: 60x24 RMV: 8370
 Func Obsc: 100 Econ %: 100 Other %: 100 Exception: 0 Adjust: Adjust RMV: 0

Floors

Type	Class	Display Group	Floor Size	Beds	Baths	Yr Blt	Eff Yr Blt	Inventory	Exception
General Purpose Bldg	4	Finished	1440	0	0	1993	1993	FAIR ✓	Y N

Accessories

Description	Class	Size SqFt	Eff Yr Blt	RMV	Quantity
No accessory data available					

Bldg: 3 Code Area: 05558 Stat Class: 301 Year Blt: Eff Year Blt: Sq.Ft: 64 % Complete: 100
 Desc: Accessory Improvements & Misc. Dimensions: 8x8 RMV: 0
 Func Obsc: 100 Econ %: 100 Other %: 100 Exception: 0 Adjust: Adjust RMV: 0

Floors

Type	Class	Display Group	Floor Size	Beds	Baths	Yr Blt	Eff Yr Blt	Inventory	Exception
Pump House	0	Finished	64	0	0	0	0		Y N

Accessories

Description	Class	Size SqFt	Eff Yr Blt	RMV	Quantity
-------------	-------	-----------	------------	-----	----------

No accessory data available

SKETCH/AREA TABLE ADDENDUM

SUBJECT INFO

File No.: 530380 Parcel No.: 082W24B 02000
 Property Address: 8555 AUMSVILLE HY SE
 City: SALEM County: MARION State: OR ZipCode: 97317
 Owner:
 Client: Client Address:
 Appraiser Name: Inspection Date:

SKETCH

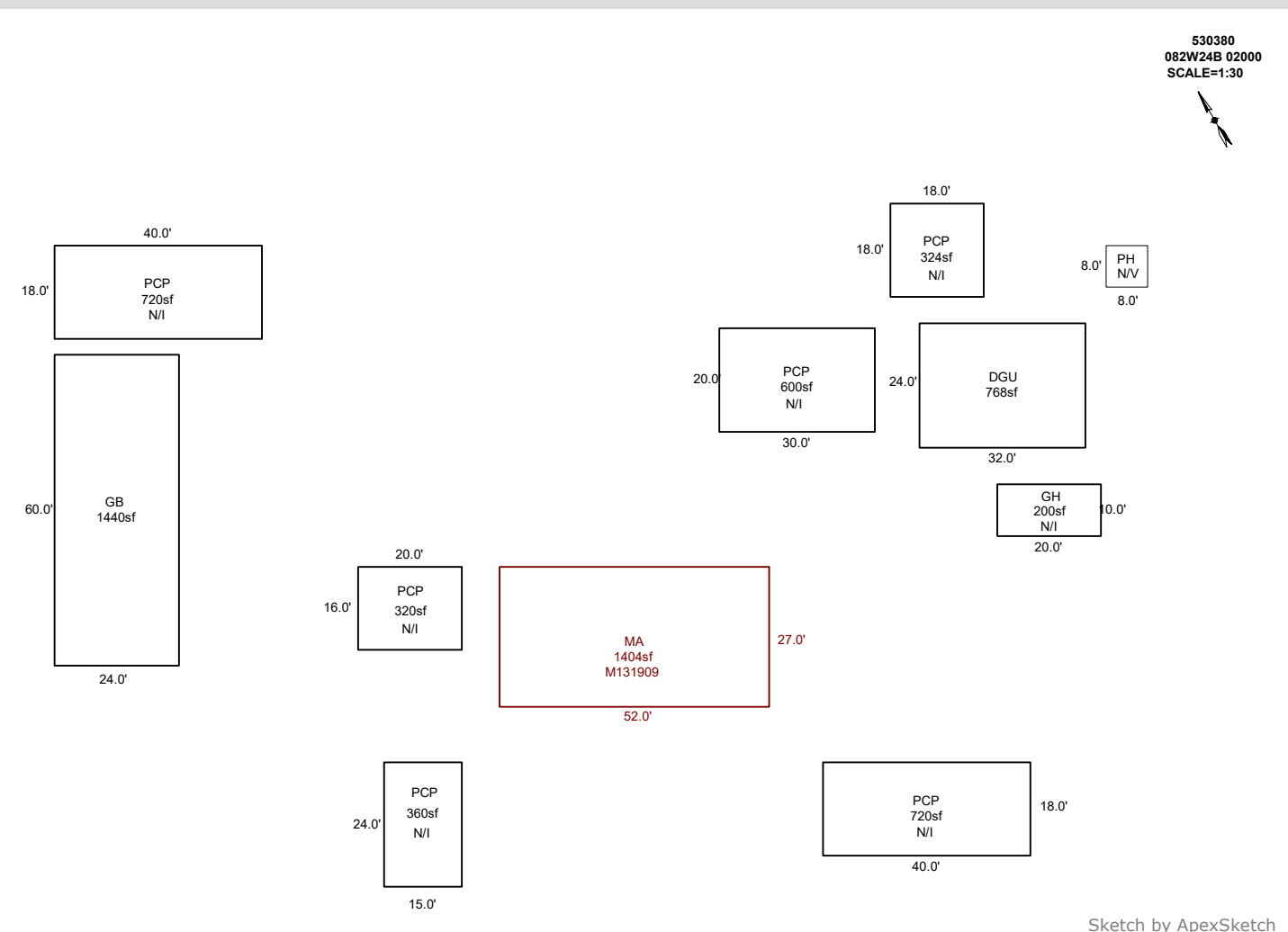

Sketch by ApexSketch

AREA CALCULATIONS SUMMARY						COMMENT TABLE 1	
Code	Description	Factor	Net Size	Perimeter	Net Totals		
GBA1	GB	1.0	1440.0	168.0		DRAWN BY JRONDEMA 3/16/18 UPDATED BY CLOBERG 08/22/25	
	GH	1.0	200.0	60.0	1640.0		
GLA1	MA	1.0	1404.0	158.0	1404.0		
GAR	DGU	1.0	768.0	112.0			
	PCP	1.0	720.0	116.0			
	PCP	1.0	320.0	72.0			
	PCP	1.0	360.0	78.0			
	PCP	1.0	720.0	116.0			
	PCP	1.0	600.0	100.0			
	PCP	1.0	324.0	72.0	3812.0		
	Net LIVABLE	cnt	0	(rounded)	1,404		
	Net BUILDING	cnt	2	(rounded)	1,640		

COMMENT TABLE 2	COMMENT TABLE 3
MDL 07/03/25	CYCLE L3

SKETCH/AREA TABLE ADDENDUM

Parcel No 082W24B 02000

File No R30380

SUBJECT	Property Address 8555 AUMSVILLE HY SE		
	City SALEM	County MARION	State OR
	Owner	Zip 97317	
	Client		
	Appraiser Name		

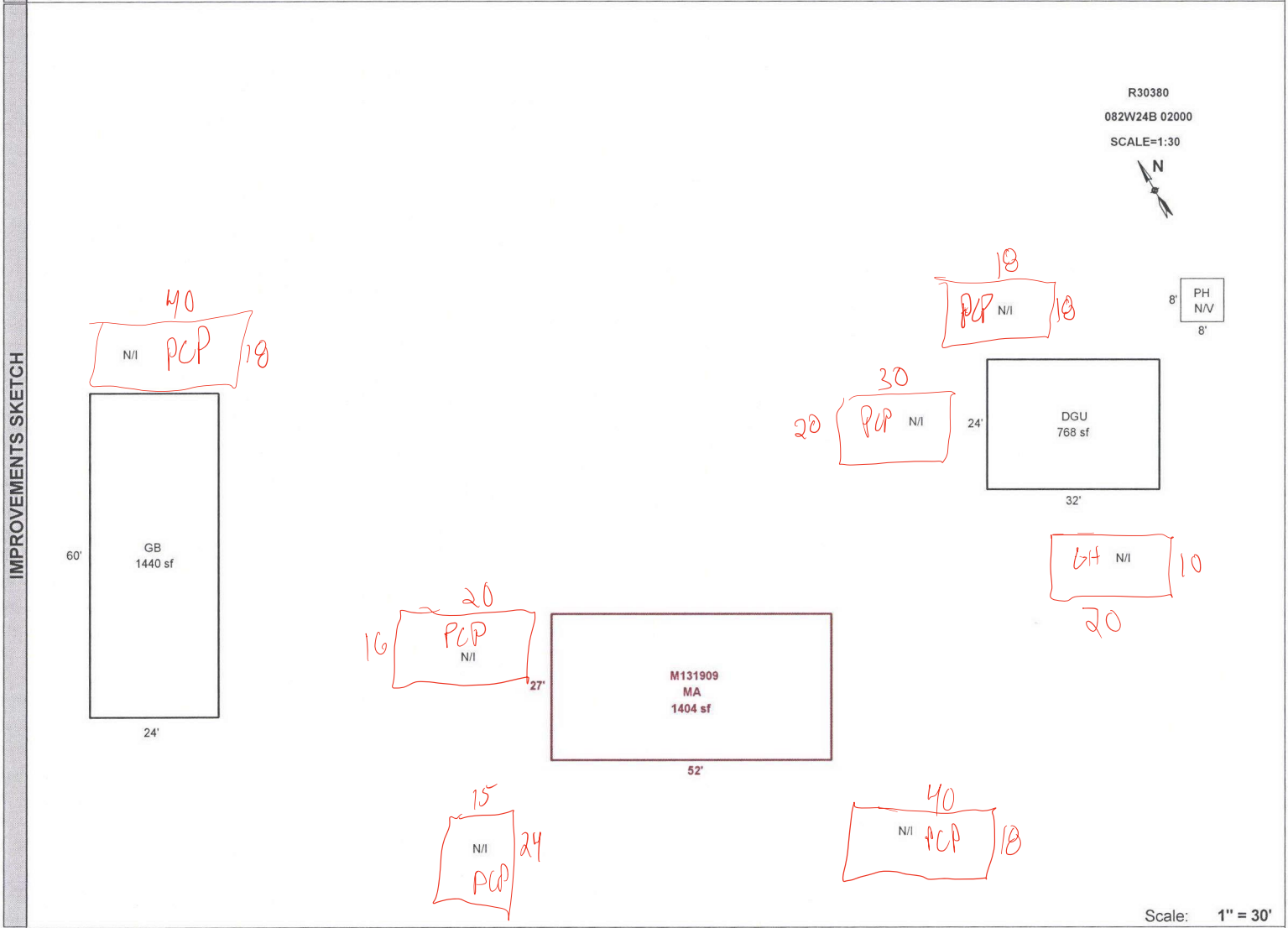

AREA CALCULATIONS	AREA CALCULATIONS SUMMARY					
	Code	Description	Factor	Net Size	Perimeter	Net Totals
	GLA1	MA	1.00	1404	158	1404
	GBA1	GB	1.00	1440	168	1440
	GAR	DGU	1.00	768	112	768
Net LIVABLE Area			(rounded w/ factors)		1404	
Net BUILDING Area			(rounded w/ factors)		1440	

Comment Table 1	
DRAWN BY JRONDEMA 3/16/18	
Comment Table 2	Comment Table 3





R30380 082W24B 02000 Appr #: 30 Date 9/26/14 Prop Class 401 Prop Code F09
 Situs Address 8555 AUMSVILLE HY SE 97317 Franchise Code 36 Year For: 2014-2015
 Owner CLARK, JIMMIE W & 15-16

Notes: locked gate, viewed at distance Tags Cycle Sales Verification Other: _____
 RMV Land: 135,830 RMV Imp: 35,570 RMV Total: 171,400 M50 Total: 131,170

Accessory Improvements

Seg.Type ~~Y13F~~ Seg. # 1.2 Method: R05 Class Area 1 Eff Area 1
 Length Y13A Width Foundation Ex. Wall Roof Cover
 Roof Style Floor Plumbing
 Year Built Eff. Year Built: Cond. P F A G E % Comp ___ Econ ___ RMV: 3,000
 Lump Sum ___ Except Code/Year ___ Comments AJ

Out Buildings

Seg.Type DGU Seg. # 1.1 Method: R05 Class 4 Area 768 Eff Area 768
 Length 32 Width 24 Foundation Ex. Wall Roof Cover COMP
 Roof Style Floor Plumbing
 Heat Int. Comp. Elect. Yr. Blt. 1981 Eff. Yr. Blt: 1981
 Cond. P F A G E Adj. Codes RLCM4 % Comp ___ Func ___ Econ ___ RMV: 26,190
 Lump Sum ___ Except Code/Year ___ Comments ___

Seg.Type GB Seg. # 2.1 Method: F09 Class 4 Area 1440 Eff Area 1440
 Length 60 Width 24 Foundation CONC Ex. Wall METAL;BKEN Roof Cover METAL
 Roof Style Floor CONC Plumbing
 Heat Int. Comp. Elect. Yr. Blt. Eff. Yr. Blt: 1981
 Cond. P F A G E Adj. Codes FLCM % Comp ___ Func ___ Econ ___ RMV: 6,380
 Lump Sum ___ Except Code/Year ___ Comments ___

Seg.Type PH Seg. # 3.1 Method: F;N Class Area 64 Eff Area 64
 Length 8 Width 8 Foundation CONC Ex. Wall PLYWD Roof Cover COMP
 Roof Style Floor CONC Plumbing
 Heat Int. Comp. Elect. Yr. Blt. Eff. Yr. Blt:
 Cond. P F A G E Adj. Codes FLCM % Comp ___ Func ___ Econ ___ RMV: 0
 Lump Sum ___ Except Code/Year ___ Comments ___

R30380 082W24B 02000 Appr #: 36 Date 9/26/14 Prop Class 401 Prop Code F09
 Situs Address 8555 AUMSVILLE HY SE 97317 Franchise Code 36 Year For: 2014-2015
 Owner CLARK, JIMMIE W & 15-16

Tags Cycle Sales Verification Other: _____

Notes: _____
 RMV Land: 135,830 RMV Imp: 35,570 RMV Total: 171,400 M50 Total: 131,170

Segment							Land
Class							
Dim/Size							
Foundation							
Exter Wall							
Wall Height							
Inter Finish							
Roof Cover							
Roof Style							
Flooring							
Plumbing							
Electric							
Misc.							
Yr Blt							
Eff Yr							
Cond.							
% Good							
% Comp							
Lump Sum							
Except.Code							

Land Segments

Seg. No	Description	Schedule	Acres	Adjustment Codes	Exception Code
1	RURAL AT MKT	008S	5.00		
2	ON SITE DEVELOPMENT	OSDA.RUR			

Eff Acres Companion Accounts M131909 082W24B 02000

Zone: AR

Date 10/3/14 Clerk Chus **ROUTING SLIP**

Work Needed: (Please make necessary comments, sign and pass to the next appropriate person.)

- Data entry reviewed by/comments _____
- APEX: Please review and return appraisal jacket to clerical staff for Apex attachment to TSG.
- Appraiser response _____
- Reviewed by lead appraiser/comments _____





R30380

9/26/14



R30380 82W-24B-2000 5/23/02

