

Acct ID: 533810 MTL: 084W36DC00700 Date: 7/30/25 Appr: GAH Prop Class: 451 RMV Prop Class: 451
 Situs: 4468 FOX LN S SALEM OR 97306 MaSaNh: 06 06 000 Unit: 58215 Year: 2025

Last Date Appraised: 03/26/2024 Appraiser: GERARDO RAMIREZ HERNANDEZ Retag: Y N Tag info: 2024 - Tags/Permit (Completion)

Owner: SMITH, AARON & SMITH, HALLIE KAY

Roll Type: R

Cycle Tag Sales Verification Other: _____ Inspection level: 1 2 3 4 LCB TTO INSP

AV: 525320

RMV Land: 342860 RMV Imp: 611720 RMV Total: 954580 MAV: 525320 MSAV: 0 SAV: 0

Comment: 24-25: L1 3.26.24 WW
 24-25: L4 09.13.23 WW
 23-24: L2 12.15.22 GRH
 22-23: L2 12/15/2021 ML

Notations No changes

No notation data available.

OSDs

Count	Code	Description	RMV	Code Area	Exception
1	MKTA	OSD - AVERAGE	50000	14460	0

Land

Site: 1 Code Area: 14460 Size: 2.31 Acres Use Code: 005 Zone: REST SAV Use: Exception: 0
 Class: 2BDS Value Source: Rural Restrictive Description: TWO BENCH DRY SOUTH SPECIAL RMV: 292860 Exception: Y N
 S
 Adjustment(s): H2OGR, GSOIL Fire Patrol: Description:
 Comments: 01-02; REAPPRAISAL

Improvements - Residence / Manufactured Structures

Bldg: 1 Code Area: 14460 Stat Class: 143 + Year Blt: 1962 Eff Year Blt: 2010 Sq.Ft: 3713 % Complete: 100
 Desc: One Story with basement Dimensions: RMV: 599390
 Func Obsc: 100 Econ %: 100 Other %: 100 Exception: 0 Adjust: Adjust RMV: 0

Floors

Type	Class	Display Group	Floor Size	Beds	Baths	Yr Blt	Eff Yr Blt	Inventory	Exception
First Floor	4 +	Finished	1426	1	FB-1/ HB-1	1962	2010	ROOF, HVAC+, BATH - 1, KIT+, BTH - 1	Y N
First Floor	4 +	Finished	884	0	0	1962	2010		Y N
Basement	4 +	Finished	1403	2	FB-2	1962	2010	HVAC, BATH - 2	Y N

Accessories

Description	Class	Size SqFt	Eff Yr Blt	RMV	Quantity	Exception
YARD IMPROVEMENTS AVERAGE	4	0	2010	29853	1	Y N

Improvements - Accessory Buildings

Bldg: 3 Code Area: 14460 Stat Class: 351 Year Blt: 1960 Eff Year Blt: 1998 Sq.Ft: 1668 % Complete: 100
 Desc: General Purpose Building (GB) Dimensions: 60x20 RMV: 11860
 Func Obsc: 100 Econ %: 100 Other %: 100 Exception: 0 Adjust: Adjust RMV: 0

Floors

Type	Class	Display Group	Floor Size	Beds	Baths	Yr Blt	Eff Yr Blt	Inventory	Exception
General Purpose Bldg	4	Finished	1668	0	0	1960	1998	FAIR	Y N

Accessories

Description	Class	Size SqFt	Eff Yr Blt	RMV	Quantity	Exception
No accessory data available						

Bldg: 6 Code Area: 14460 Stat Class: 354 Year Blt: Eff Year Blt: 1998 Sq.Ft: 240 % Complete: 100
 Desc: Lean-to Light (LTL) Dimensions: 20x12 RMV: 470
 Func Obsc: 100 Econ %: 100 Other %: 100 Exception: 0 Adjust: Adjust RMV: 0

Floors

Type	Class	Display Group	Floor Size	Beds	Baths	Yr Blt	Eff Yr Blt	Inventory	Exception
Lean-to Light Duty	4	Finished	240	0	0	0	1998		Y N

Accessories

Description	Class	Size SqFt	Eff Yr Blt	RMV	Quantity	Exception
No accessory data available						



SKETCH/AREA TABLE ADDENDUM

SUBJECT INFO

File No.: 533810 Parcel No.: 084W36DC00700
 Property Address: 4468 FOX LN S
 City: SALEM County: State: OR ZipCode: 97306
 Owner:
 Client: Client Address:
 Appraiser Name: Inspection Date:

SKETCH

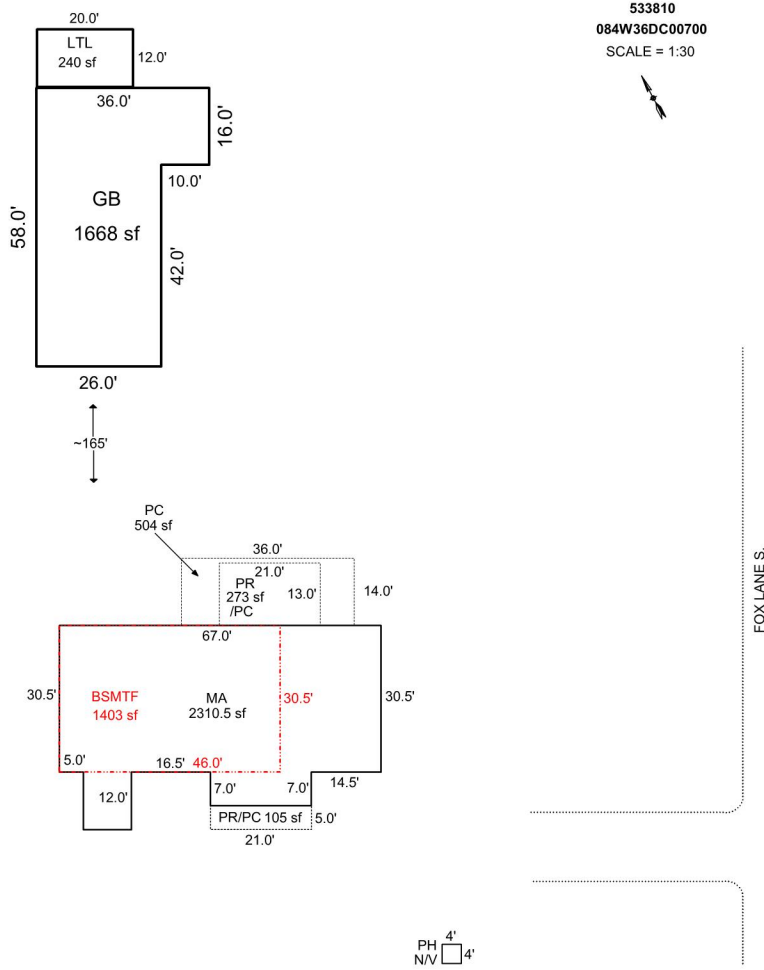

Sketch by ApexSketch

AREA CALCULATIONS SUMMARY

Code	Description	Factor	Net Size	Perimeter	Net Totals
GBA1	LTL	1.0	240.0	64.0	
	GB	1.0	1668.0	188.0	1908.0
GLA1	MA	1.0	2310.5	233.0	2310.5
BSMT	BSMTF	1.0	1403.0	153.0	1403.0
P/P	PC	1.0	504.0	100.0	
	PR	1.0	273.0	68.0	
	PR/PC	1.0	105.0	52.0	882.0
	Net LIVABLE	cnt	1 (rounded)		2,311
	Net BUILDING	cnt	2 (rounded)		1,908

COMMENT TABLE 1

APEX BY CE 11/18/09
 UPDATED BY CJURAN 10/21/2021 555-21-008330
 UPDATED BY WWILLIAMS 9/13/23

COMMENT TABLE 2

12.15.21 MDL
 12.15.22 GRH
 09.13.23 WW
GRH 7/30/25

COMMENT TABLE 3

TAGS L3
 TAGS L2
 TAGS L4
Cycle L3