

Summary Lead Appr: WW Clerk: _____ Lead Clerk: _____ Appr: _____ Print Date: 1/25/2024

Acct ID: 536233 MTL: 093W090000300 Date: 9-10-24 Appr: WW Prop Class: 551 RMV Prop Class: 551
Situs: 10355 LIBERTY RD S SALEM OR 97306 MaSaNh: 06 06 000 Unit: 45402 Year: 2024

Last Date Appraised: 09/08/2009 Appraiser: WENDY WILLIAMS Retag: Y N Tag info:

Owner: EQUINE LLC Roll Type: R

Cycle Tag Sales Verification Other: _____ Inspection level: 1 2 3 4 LCB TTO INSP AV: 797616

RMV Land: 770640 RMV Imp: 808180 RMV Total: 1578820 MAV: 659140 MSAV: 138476 SAV: 273019

Comment: update

Notations

RP/MS	Code	Description
MS	ZONED	FARM EFU ZONED
MS	ZONED	FARM EFU ZONED

OSDs

Count	Code	Description	RMV	Code Area	Exception
1	SAA	SA OSD - AVERAGE	45000	14530	0
1	SAG	SA OSD - GOOD	55000	14530	0

Land

See attached excel sheet for all changes

Site: 1	Code Area: 14530	Size: 1.00 Acres	Use Code: 005	Zone: REST	SAV Use: 011	Exception: 0
Class: 2BDS S	Value Source: Farm Homesite	Description: TWO BENCH DRY SOUTH SPECIAL			RMV: 4950	Exception: Y N
Adjustment(s): GSOIL, FSOIL, WASTE		Fire Patrol:	Description:			
Comments: Liability year - 2009 / 81400130						
Site: 2	Code Area: 14530	Size: 1.00 Acres	Use Code: 005	Zone: REST	SAV Use: 011	Exception: 0
Class: 4BDS S	Value Source: Farm Homesite	Description: FOUR BENCH DRY SPECIAL SOUTH			RMV: 4500	Exception: Y N
Adjustment(s): GSOIL, FSOIL, WASTE		Fire Patrol:	Description:			
Comments: Liability year - 2009 / 81400130						
Site: 3	Code Area: 14530	Size: 10.00 Acres	Use Code: 005	Zone: REST	SAV Use: 011	Exception: 0
Class: 2BDS S	Value Source: Farm Use - EFU	Description: TWO BENCH DRY SOUTH SPECIAL			RMV: 49500	Exception: Y N
Adjustment(s): GSOIL, FSOIL, WASTE		Fire Patrol:	Description:			
Comments: Liability year - 1980 / 81400130						
Site: 4	Code Area: 14530	Size: 36.00 Acres	Use Code: 005	Zone: REST	SAV Use: 011	Exception: 0
Class: 2BDS S	Value Source: Farm Use - EFU	Description: TWO BENCH DRY SOUTH SPECIAL			RMV: 178200	Exception: Y N
Adjustment(s): GSOIL, FSOIL, WASTE		Fire Patrol:	Description:			
Comments: Liability year - 1980 / 81400130 //08-09: 8BENCH PROJECT - CHG OF 8HILL TO 6HILL AND CORRECT ACREAGE OF 2BENCH,4BENCH ,4HILL AND ADD 4.5 POND//						
Site: 5	Code Area: 14530	Size: 41.00 Acres	Use Code: 005	Zone: REST	SAV Use: 011	Exception: 0
Class: 4BDS S	Value Source: Farm Use - EFU	Description: FOUR BENCH DRY SPECIAL SOUTH			RMV: 184500	Exception: Y N
Adjustment(s): GSOIL, FSOIL, WASTE		Fire Patrol:	Description:			
Comments: Liability year - 1980 / 81400130/01-02: COMBINED LAND SEGGS - SAME SOIL CLASS, SAME LIAB YR, 27.07 TTL ACRES						
Site: 6	Code Area: 14530	Size: 11.11 Acres	Use Code: 005	Zone: REST	SAV Use: 011	Exception: 0
Class: 4HD	Value Source: Farm Use - EFU	Description: FOUR HILL DRY			RMV: 50000	Exception: Y N
Adjustment(s): GSOIL, FSOIL, WASTE		Fire Patrol:	Description:			
Comments: Liability year - 1980 / 81400130						
Site: 7	Code Area: 14530	Size: 26.70 Acres	Use Code: 005	Zone: REST	SAV Use: 011	Exception: 0
Class: 6H	Value Source: Farm Use - EFU	Description: SIX HILL			RMV: 114140	Exception: Y N
Adjustment(s): GSOIL, FSOIL, WASTE		Fire Patrol:	Description:			
Comments: Liability year - 1980 / 81400130 /01-02: COMBINED LAND SEGGS - SAME SOIL CLASS, SAME LIAB YR, 67.54 TTL ACRES //05-06: ONSITE BY #17 SHOWS 20 ACRES FROM 8HILL TO WOODLOT						
Site: 8	Code Area: 14530	Size: 14.00 Acres	Use Code: 005	Zone: REST	SAV Use: 011	Exception: 0
Class: WST	Value Source: WASTE RURAL	Description: Rural WASTELAND			RMV: 1890	Exception: Y N
Adjustment(s): GSOIL, FSOIL, WASTE		Fire Patrol:	Description:			
Comments: Liability year - 1980 / 81400130						
Site: 10	Code Area: 14530	Size: 18.30 Acres	Use Code: 005	Zone: REST	SAV Use: 011	Exception: 0
Class: 4HD	Value Source: Woodlot	Description: FOUR HILL DRY			RMV: 82350	Exception: Y N
Adjustment(s): GSOIL, FSOIL, WASTE		Fire Patrol:	Description:			
Comments: Liability year - 1980 / 81400130 /01-02: COMBINED LAND SEGGS - SAME SOIL CLASS, SAME LIAB YR, 67.54 TTL ACRES //05-06: ONSITE BY #17 SHOWS 20 ACRES FROM 8HILL TO WOODLOT						
Site: 11	Code Area: 14530	Size: 4.50 Acres	Use Code: 005	Zone: REST	SAV Use: 011	Exception: 0
Class: WST	Value Source: Water	Description: Rural WASTELAND			RMV: 610	Exception: Y N
Adjustment(s): GSOIL, FSOIL, WASTE		Fire Patrol:	Description:			
Comments: Liability year - 1980 / 81400130						

Improvements - Residence / Manufactured Structures

Bldg: 1	Code Area: 14530	Stat Class: 144	Year Blt: 1878	Eff Year Blt: 1965	Sq.Ft: 3452	% Complete: 100
Desc: Multi Story above grade with basement			Dimensions:		RMV: 371740	
Func Obsc: 100	Econ %: 100	Other %: 100	Exception: 0	Adjust:	Adjust RMV: 0	

Floors

Type	Class	Display Group	Floor Size	Beds	Baths	Yr Blt	Eff Yr Blt	Inventory	Exception: Y N
First Floor	4	Finished	2296	1	FB-1	1878	1965	KIT-, HVAC+, FP - 1, ROOF, BATH - 1	Exception: Y N
Second Floor	4	Finished	1156	4	FB-1	1965	1965	BATH - 1, HVAC+	Exception: Y N
Basement	4	Unfinished	256	0	0	1965	1965		Exception: Y N

Accessories

Description	Class	Size SqFt	Eff Yr Blt	RMV	Quantity	Exception: Y N
CONCRETE DRIVEWAY	4	448	1970	1077	1	Exception: Y N
DECK	4	1329	1980	20998	1	Exception: Y N
PATIO	4	1374	1980	5970	1	Exception: Y N
SWIMMING POOL	4	504	2001	19505	1	Exception: Y N

Bldg: 15	Code Area: 14530	Stat Class: 148	Year Blt: 2001	Eff Year Blt: 2001	Sq.Ft: 0	% Complete: 100
Desc: Res other improvements			Dimensions:		RMV: 191260	

Func Obsc: 100 Econ %: 100 Other %: 100 Exception: 0 Adjust: Adjust RMV: 0

Floors

Type	Class	Display Group	Floor Size	Beds	Baths	Yr Blt	Eff Yr Blt	Inventory	Exception: Y N
Garage Oversized Detached	4	Finished	3360	0	0	2001	2001	ROOF	

336

Accessories

Description	Class	Size SqFt	Eff Yr Blt	RMV	Quantity
No accessory data available					

Bldg: 16 Code Area: 14530 Stat Class: 108 Year Blt: 2001 Eff Year Blt: 2001 Sq.Ft: 0 % Complete: 100
 Desc: Residential Other Improvements Dimensions: RMV: 40390
 Func Obsc: 100 Econ %: 100 Other %: 100 Exception: 0 Adjust: Adjust RMV: 0

Floors

Type	Class	Display Group	Floor Size	Beds	Baths	Yr Blt	Eff Yr Blt	Inventory	Exception: Y N
No floor data available									

1

Accessories

Description	Class	Size SqFt	Eff Yr Blt	RMV	Quantity	Exception: Y N
DECK	1	818	2001	14560	1	Exception: Y N
PATIO	1	288	2001	1410	1	Exception: Y N
ROOF EXTENSION OR PATIO COVER	1	946	2001	24416	1	Exception: Y N

Improvements - Accessory Buildings

Bldg: 2 Code Area: 14530 Stat Class: 321 Year Blt: 2001 Eff Year Blt: 2001 Sq.Ft: 432 % Complete: 100
 Desc: Hay Cover (HC) Dimensions: 36x12 RMV: 1590
 Func Obsc: 100 Econ %: 100 Other %: 100 Exception: 0 Adjust: Adjust RMV: 0

Floors

Type	Class	Display Group	Floor Size	Beds	Baths	Yr Blt	Eff Yr Blt	Inventory	Exception: Y N
Hay Cover	4	Finished	432	0	0	2001	2001		

fair

Accessories

Description	Class	Size SqFt	Eff Yr Blt	RMV	Quantity
No accessory data available					

Bldg: 3 Code Area: 14530 Stat Class: 353 Year Blt: 2001 Eff Year Blt: 2001 Sq.Ft: 960 % Complete: 100
 Desc: Machine Shed (MS) Dimensions: 60x16 RMV: 5380
 Func Obsc: 100 Econ %: 100 Other %: 100 Exception: 0 Adjust: Adjust RMV: 0

Floors

Type	Class	Display Group	Floor Size	Beds	Baths	Yr Blt	Eff Yr Blt	Inventory	Exception: Y N
Machine Shed	4	Finished	960	0	0	2001	2001		

fair

Accessories

Description	Class	Size SqFt	Eff Yr Blt	RMV	Quantity
No accessory data available					

Bldg: 4 Code Area: 14530 Stat Class: 321 Year Blt: 2001 Eff Year Blt: 2001 Sq.Ft: 1680 % Complete: 100
 Desc: Hay Cover (HC) Dimensions: 60x28 RMV: 6170
 Func Obsc: 100 Econ %: 100 Other %: 100 Exception: 0 Adjust: Adjust RMV: 0

Floors

Type	Class	Display Group	Floor Size	Beds	Baths	Yr Blt	Eff Yr Blt	Inventory	Exception: Y N
Hay Cover	4	Finished	1680	0	0	2001	2001		

fair

Accessories

Description	Class	Size SqFt	Eff Yr Blt	RMV	Quantity
No accessory data available					

Bldg: 5 Code Area: 14530 Stat Class: 301 Year Blt: Eff Year Blt: Sq.Ft: 0 % Complete: 100
 Desc: Accessory Improvements & Misc. Dimensions: RMV: 8000
 Func Obsc: 100 Econ %: 100 Other %: 100 Exception: 0 Adjust: Adjust RMV: 0

Floors

Type	Class	Display Group	Floor Size	Beds	Baths	Yr Blt	Eff Yr Blt	Inventory	Exception: Y N
Building Structure	0	Finished	0	0	0	0	0		

gate

Accessories

Description	Class	Size SqFt	Eff Yr Blt	RMV	Quantity
No accessory data available					

Bldg: 6 Code Area: 14530 Stat Class: 341 Year Blt: 2001 Eff Year Blt: 2001 Sq.Ft: 256 % Complete: 100
 Desc: Multi Purpose Shed (MP) Dimensions: 32x8 RMV: 3590
 Func Obsc: 100 Econ %: 100 Other %: 100 Exception: 0 Adjust: Adjust RMV: 0

Floors

Type	Class	Display Group	Floor Size	Beds	Baths	Yr Blt	Eff Yr Blt	Inventory	Exception: Y N
Multi-Purpose Bldg	5	Finished	256	0	0	2001	2001	FAIR	

Accessories

Description	Class	Size SqFt	Eff Yr Blt	RMV	Quantity
No accessory data available					

Bldg: 7 Code Area: 14530 Stat Class: 312 Year Blt: 2001 Eff Year Blt: 2001 Sq.Ft: 2520 % Complete: 100
 Desc: Loft Barn (LB) Dimensions: 60x42 RMV: 18030
 Func Obsc: 50 Econ %: 100 Other %: 100 Exception: 0 Adjust: Adjust RMV: 0

Floors

Type	Class	Display Group	Floor Size	Beds	Baths	Yr Blt	Eff Yr Blt	Inventory	Exception: Y N
Loft Barn	4	Finished	2520	0	FB-1/ HB-1	2001	2001	BTH - 1, FAIR	

Accessories

Description	Class	Size SqFt	Eff Yr Blt	RMV	Quantity
No accessory data available					

Bldg: 8 Code Area: 14530 Stat Class: 353 Year Blt: 2001 Eff Year Blt: 2001 Sq.Ft: 1200 % Complete: 100
 Desc: Machine Shed (MS) Dimensions: 50x24 RMV: 10330
 Func Obsc: 100 Econ %: 100 Other %: 100 Exception: 0 Adjust: Adjust RMV: 0

Floors

Type	Class	Display Group	Floor Size	Beds	Baths	Yr Blt	Eff Yr Blt	Inventory	Exception: Y N
Machine Shed	5	Finished	1200	0	0	2001	2001	FAIR	

Accessories

Description	Class	Size SqFt	Eff Yr Blt	RMV	Quantity
No accessory data available					

Bldg: 9 Code Area: 14530 Stat Class: 317 Year Blt: 2001 Eff Year Blt: 2001 Sq.Ft: 240 % Complete: 100
 Desc: Hobby Stables (HS) Dimensions: 20x12 RMV: 6430
 Func Obsc: 100 Econ %: 100 Other %: 100 Exception: 0 Adjust: Adjust RMV: 0

Floors

Type	Class	Display Group	Floor Size	Beds	Baths	Yr Blt	Eff Yr Blt	Inventory	Exception: Y N
Hobby Stable	5	Finished	240	0	0	2001	2001	FAIR	

Accessories

Description	Class	Size SqFt	Eff Yr Blt	RMV	Quantity
No accessory data available					

Bldg: 10 Code Area: 14530 Stat Class: 316 Year Blt: 1996 Eff Year Blt: 1996 Sq.Ft: 12560 % Complete: 100
 Desc: Arenas (HA) Dimensions: 157x80 RMV: 88610
 Func Obsc: 100 Econ %: 100 Other %: 100 Exception: 0 Adjust: Adjust RMV: 0

Floors

Type	Class	Display Group	Floor Size	Beds	Baths	Yr Blt	Eff Yr Blt	Inventory	Exception: Y N
Horse Arena	5	Finished	12560	0	0	1996	1996	FAIR	

Accessories

Description	Class	Size SqFt	Eff Yr Blt	RMV	Quantity
No accessory data available					

Bldg: 11 Code Area: 14530 Stat Class: 355 Year Blt: 1996 Eff Year Blt: 1996 Sq.Ft: 5690 % Complete: 100
 Desc: Lean-to Heavy (LTH) Dimensions: RMV: 17670
 Func Obsc: 100 Econ %: 100 Other %: 100 Exception: 0 Adjust: Adjust RMV: 0

Floors

Type	Class	Display Group	Floor Size	Beds	Baths	Yr Blt	Eff Yr Blt	Inventory	Exception: Y N
Lean-to Heavy Duty	4	Finished	5690	0	0	1996	1996		

Accessories

Description	Class	Size SqFt	Eff Yr Blt	RMV	Quantity
No accessory data available					

Bldg: 12 Code Area: 14530 Stat Class: 311 Year Blt: 2001 Eff Year Blt: 2001 Sq.Ft: 1584 % Complete: 100
 Desc: Feeder Barn (FB) Dimensions: 44x36 RMV: 11350

Func Obsc: 100 Econ %: 100 Other %: 100 Exception: 0 Adjust: Adjust RMV: 0

Floors

Type	Class	Display Group	Floor Size	Beds	Baths	Yr Blt	Eff Yr Blt	Inventory
Feeder Barn	5	Finished	1584	0	0	2001	2001	FAIR

Exception: Y N

Accessories

Description	Class	Size SqFt	Eff Yr Blt	RMV	Quantity
No accessory data available					

Bldg: 13 Code Area: 14530 Stat Class: 341 Year Blt: 2001 Eff Year Blt: 2001 Sq.Ft: 476 % Complete: 100
 Desc: Multi Purpose Shed (MP) Dimensions: 14x34 RMV: 4890
 Func Obsc: 100 Econ %: 100 Other %: 100 Exception: 0 Adjust: Adjust RMV: 0

Floors

Type	Class	Display Group	Floor Size	Beds	Baths	Yr Blt	Eff Yr Blt	Inventory
Multi-Purpose Bldg	5	Finished	476	0	0	2001	2001	FAIR

Exception: Y N

Accessories

Description	Class	Size SqFt	Eff Yr Blt	RMV	Quantity
No accessory data available					

Bldg: 14 Code Area: 14530 Stat Class: 355 Year Blt: 2001 Eff Year Blt: 2001 Sq.Ft: 280 % Complete: 100
 Desc: Lean-to Heavy (LTH) Dimensions: 10x28 RMV: 1270
 Func Obsc: 100 Econ %: 100 Other %: 100 Exception: 0 Adjust: Adjust RMV: 0

Floors

Type	Class	Display Group	Floor Size	Beds	Baths	Yr Blt	Eff Yr Blt	Inventory
Lean-to Heavy Duty	4	Finished	280	0	0	2001	2001	FAIR

Exception: Y N

Accessories

Description	Class	Size SqFt	Eff Yr Blt	RMV	Quantity
No accessory data available					

Bldg: 17 Code Area: 14530 Stat Class: 351 Year Blt: 2001 Eff Year Blt: 2001 Sq.Ft: 1200 % Complete: 100
 Desc: General Purpose Building (GB) Dimensions: 30x40 RMV: 17740
 Func Obsc: 100 Econ %: 100 Other %: 100 Exception: 0 Adjust: Adjust RMV: 0

Floors

Type	Class	Display Group	Floor Size	Beds	Baths	Yr Blt	Eff Yr Blt	Inventory
General Purpose Bldg	6	Finished	1200	0	0	2001	2001	FAIR

Exception: Y N

Accessories

Description	Class	Size SqFt	Eff Yr Blt	RMV	Quantity
No accessory data available					

Bldg: 18 Code Area: 14530 Stat Class: 354 Year Blt: 2001 Eff Year Blt: 2001 Sq.Ft: 200 % Complete: 100
 Desc: Lean-to Light (LTL) Dimensions: 10x20 RMV: 450
 Func Obsc: 100 Econ %: 100 Other %: 100 Exception: 0 Adjust: Adjust RMV: 0

Floors

Type	Class	Display Group	Floor Size	Beds	Baths	Yr Blt	Eff Yr Blt	Inventory
Lean-to Light Duty	4	Finished	200	0	0	2001	2001	FAIR

Exception: Y N

Accessories

Description	Class	Size SqFt	Eff Yr Blt	RMV	Quantity
No accessory data available					

Bldg: 19 Code Area: 14530 Stat Class: 341 Year Blt: 2001 Eff Year Blt: 2001 Sq.Ft: 280 % Complete: 100
 Desc: Multi Purpose Shed (MP) Dimensions: RMV: 3290
 Func Obsc: 100 Econ %: 100 Other %: 100 Exception: 0 Adjust: Adjust RMV: 0

Floors

Type	Class	Display Group	Floor Size	Beds	Baths	Yr Blt	Eff Yr Blt	Inventory
Multi-Purpose Bldg	5	Finished	280	0	0	2001	2001	FAIR

Exception: Y N

Accessories

Description	Class	Size SqFt	Eff Yr Blt	RMV	Quantity
No accessory data available					



ID#	YB	STAT	NAME	SIZE	
1	1878	144	MA	3452	OK
2	2001	321	HC	432	ADD FAIR
3	2001	353	MS	960	CHG TO GB AVG 2760 SF
4	2001	321	HC	1680	CHG TO 1860 ADD FAIR
5		301	ACC		GATE FLAT 8,000
6	2001	341	MP	258	CHG TO 176
7	2001	312	LB	2520	CHG TO 2400
8	2001	353	MS	1200	CHG TO GB 1008
9	2001	317	HS	240	CHG TO 400 ADD FAIR
10	1996	316	HA	12560	CHG TO 12480
11	1996	355	LTH	5690	CHG TO MS 5 353 FAIR 2000 SF
12	2001	311	FB	1584	CHG TO 2268
13	2001	341	MP	476	ADD FAIR
14	2001	355	LTH	280	CHG TO 576
15	2001	148	DGO	3360	ADD SIZE TO ROOF
16	2001	108	YI	44600-ish	YI3A FOR MFG
17	2001	351	GB	1200	OK
18	2001	354	LTL	200	OK
19	2001	341	MP	200	CHG TO 320ADD PKG
	1996	355	LTH	68X25	
	1996	355	LTH	26X22	
	1996	355	LTH	18X156	
	2001	354	LTL	16X16	
	2001	354	LTL	16X16	
	2001	354	LTL	8X20	
	2001	354	LTL	12X24	
	2001	351	GB	42X54	CL 6
	2001	354	LTL	16X42	
	2001	354	LTL	10X20	
	2001	351	MP	10X10	MP4 FAIR 100 OR LESS = NI
	2001	384	HC	24X16	HC 4 FAIR
	2001	355	LTH	14X28	
	2001	341	MP	26X12	MP 5 FAIR
	2001	341	MP	13X22	MP 5 FAIR

SKETCH/AREA TABLE ADDENDUM

SUBJECT INFO

File No.: 536233 Parcel No.: 093W09 00300
 Property Address: 10355 Liberty Rd S
 City: Salem County: State: OR ZipCode: 97306
 Owner:
 Client: Client Address:
 Appraiser Name: Inspection Date:

SKETCH

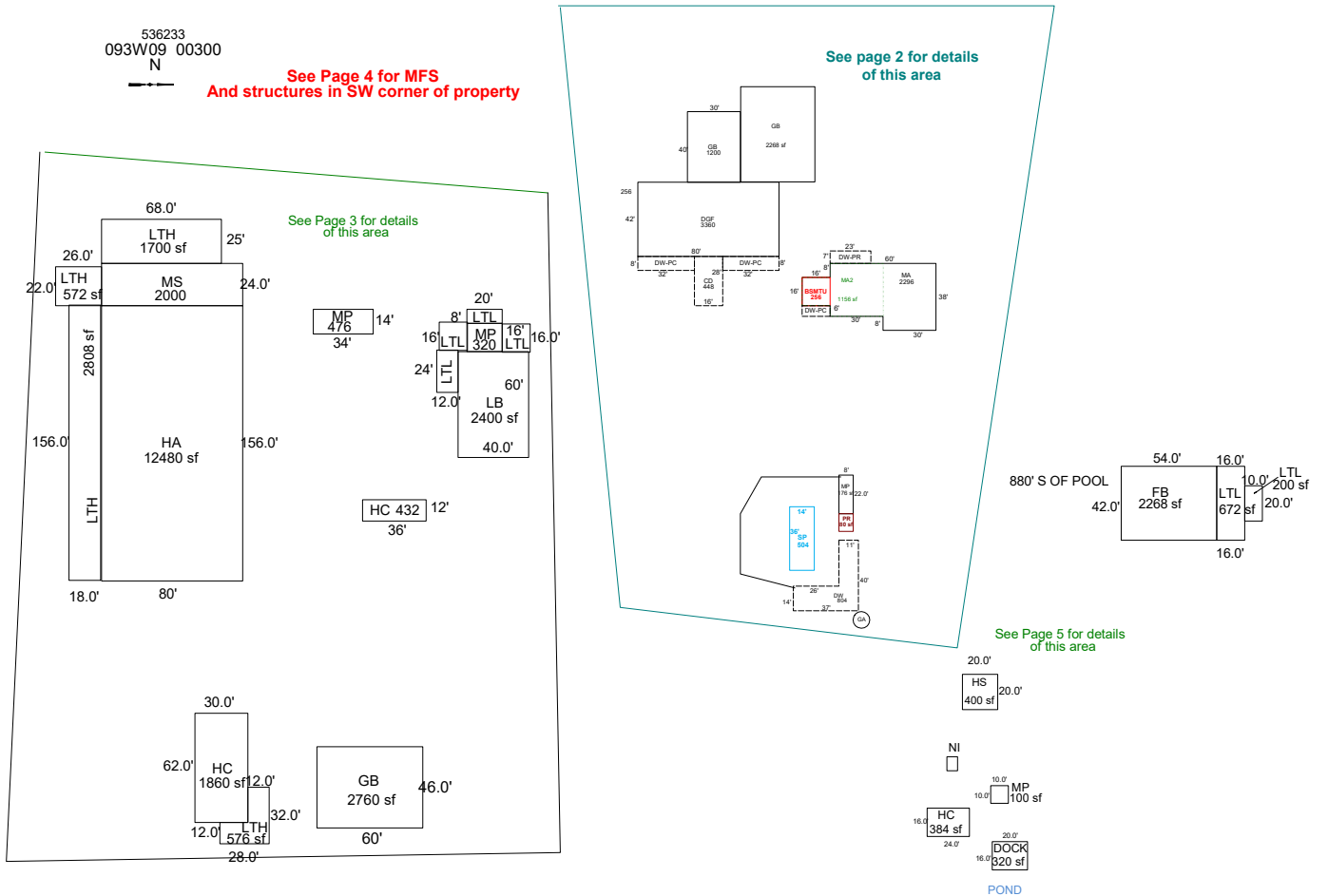

Sketch by ApexSketch

AREA CALCULATIONS SUMMARY

Code	Description	Factor	Net Size	Perimeter	Net Totals
GBA1	GB	1	2268	192	2268
GBA5	LTL	1	200	60	
	LTL	1	672	116	872
GBA6	HS	1	400	80	400
GBA7	LTH	1	576	120	576
GLA1	MA	1	2296	228	2296
GLA2	MA2	1	1156	152	1156
BSMT	BSMTU	1	256	64	256
GAR	DGF	1	3360	244	3360
OTH	MP	1	320	72	
	LTH	1	572	96	
	HC	1	384	80	
	DOCK	1	320	72	
	FB	1	2268	192	
	MP	1	100	40	
	GB	1	2760	212	
	22 addl items				
	Net LIVABLE	cnt	2 (rounded)		3,452
	Net BUILDING	cnt	5 (rounded)		4,116

COMMENT TABLE 1

Apex by JA 11/17/09
 UPD BY WW 5.6.24

COMMENT TABLE 2

COMMENT TABLE 3

SKETCH/AREA TABLE ADDENDUM

SUBJECT INFO

File No.: 536233 Parcel No.: 093W09 00300
 Property Address: 10355 Liberty Rd S
 City: Salem County: State: OR ZipCode: 97306
 Owner:
 Client: Client Address:
 Appraiser Name: Inspection Date:

SKETCH

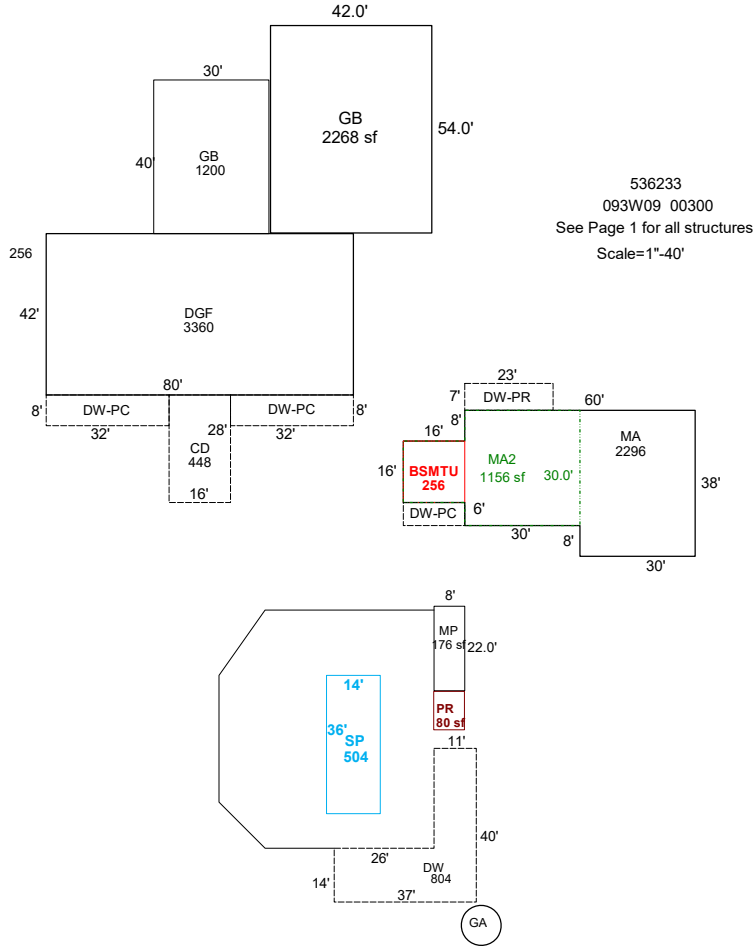

Sketch by ApexSketch

AREA CALCULATIONS SUMMARY

COMMENT TABLE 1

Code	Description	Factor	Net Size	Perimeter	Net Totals
GBA1	GB	1	2268	192	2268
GLA1	MA	1	2296	228	2296
GLA2	MA2	1	1156	152	1156
BSMT	BSMTU	1	256	64	256
GAR	DGF	1	3360	244	3360
OTH	GB	1	1200	140	
	MP	1	176	60	
	SP	1	504	100	1880
P/P	DW-PR	1	161	60	
	DW-PC	1	96	44	
	DW-PC	1	256	80	
	CD	1	448	88	
	DW-PC	1	256	80	
	PR	1	80	36	
	DW	1	804	154	2101
	Net LIVABLE	cnt	2 (rounded)		3,452
	Net BUILDING	cnt	1 (rounded)		2,268

Apex by JA 11/17/09
UPD BY WW 5.6.24

COMMENT TABLE 2

COMMENT TABLE 3

SKETCH/AREA TABLE ADDENDUM

SUBJECT INFO

File No.: 536233 Parcel No.: 093W09 00300
 Property Address: 10355 Liberty Rd S
 City: Salem County: State: OR ZipCode: 97306
 Owner:
 Client: Client Address:
 Appraiser Name: Inspection Date:

SKETCH

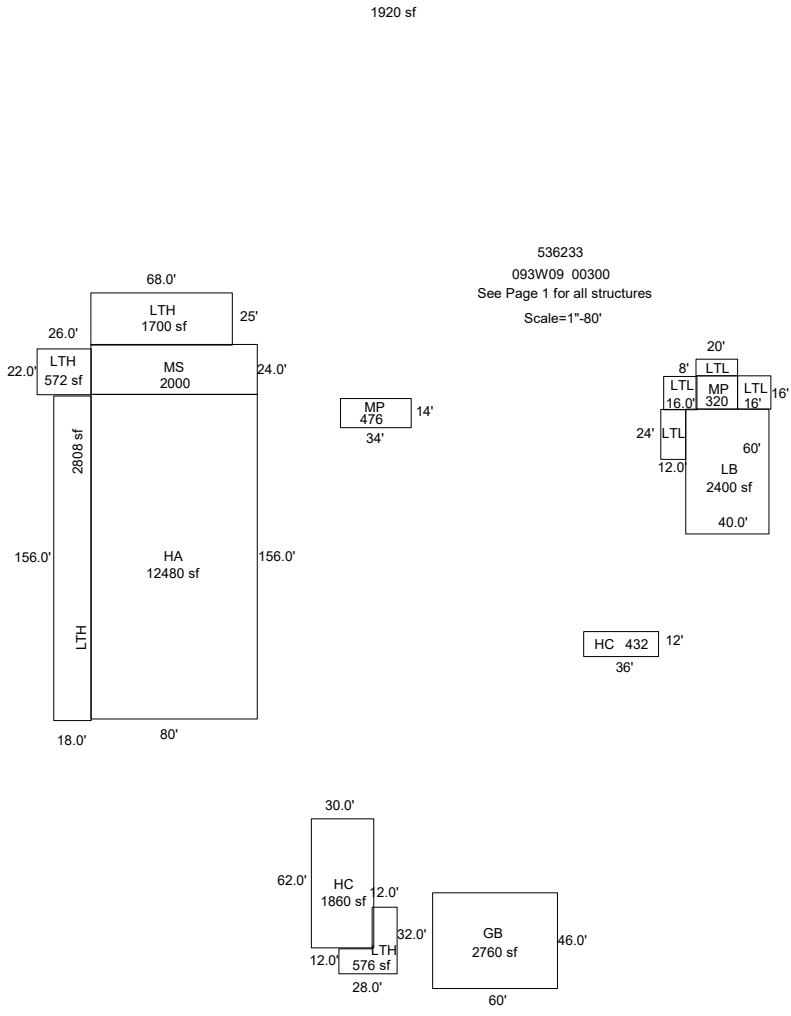

AREA CALCULATIONS SUMMARY

Code	Description	Factor	Net Size	Perimeter	Net Totals
GBA6	LTH	1	572	96	
	LTH	1	576	120	1148
OTH	HA	1	12480	472	
	LTH	1	1700	186	
	MS	1	1920	208	
	LTH	1	2808	348	
	MP	1	476	96	
	LB	1	2400	200	
	LTL	1	160	56	
	LTL	1	256	64	
	MP	1	320	72	
	LTL	1	288	72	
	HC	1	432	96	
	HC	1	1860	184	
	GB	1	2760	212	
	LTL	1	256	64	28116
	Net BUILDING	cnt	2	(rounded)	1,148

COMMENT TABLE 1

Apex by JA 11/17/09
 UPD BY WW 5.6.24

COMMENT TABLE 2

COMMENT TABLE 3

SKETCH/AREA TABLE ADDENDUM

SUBJECT INFO

File No.: 536233 Parcel No.: 093W09 00300
 Property Address: 10355 Liberty Rd S
 City: Salem County: State: OR ZipCode: 97306
 Owner:
 Client: Client Address:
 Appraiser Name: Inspection Date:

SKETCH

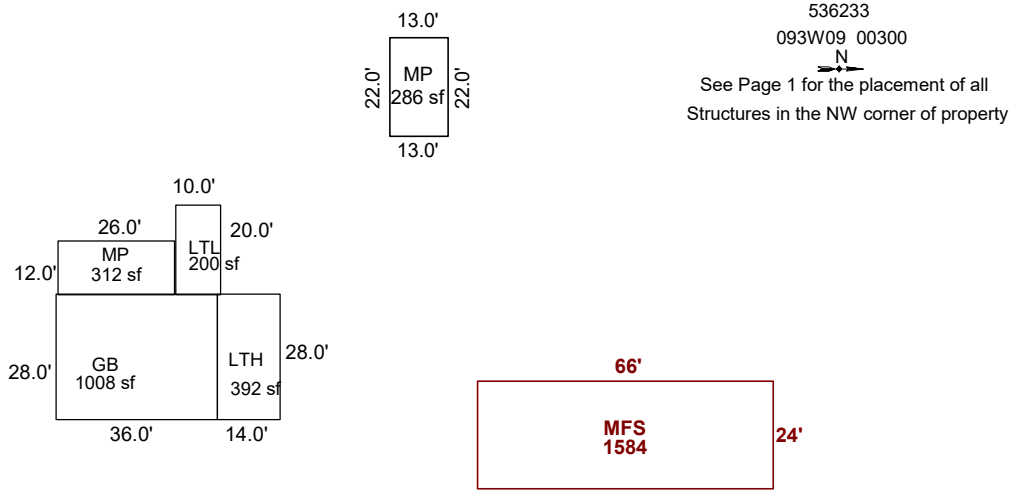

Buena Vista - Liberty Rd

Ankeny Hill Rd

Sketch by ApexSketch

AREA CALCULATIONS SUMMARY

Code	Description	Factor	Net Size	Perimeter	Net Totals
GBA3	MP	1	286	70	286
GLA1	MFS	1	1584	180	1584
OTH	GB	1	1008	128	
	LTH	1	392	84	
	LTH	1	200	60	
	MP	1	312	76	1912

COMMENT TABLE 1

Apex by JA 11/17/09
 UPD BY WW 5.6.24

COMMENT TABLE 2

COMMENT TABLE 3

Net LIVABLE	cnt	1	(rounded)		1,584
Net BUILDING	cnt	1	(rounded)		286

SKETCH/AREA TABLE ADDENDUM

SUBJECT INFO

File No.: 536233 Parcel No.: 093W09 00300
 Property Address: 10355 Liberty Rd S
 City: Salem County: State: OR ZipCode: 97306
 Owner:
 Client: Client Address:
 Appraiser Name: Inspection Date:

SKETCH

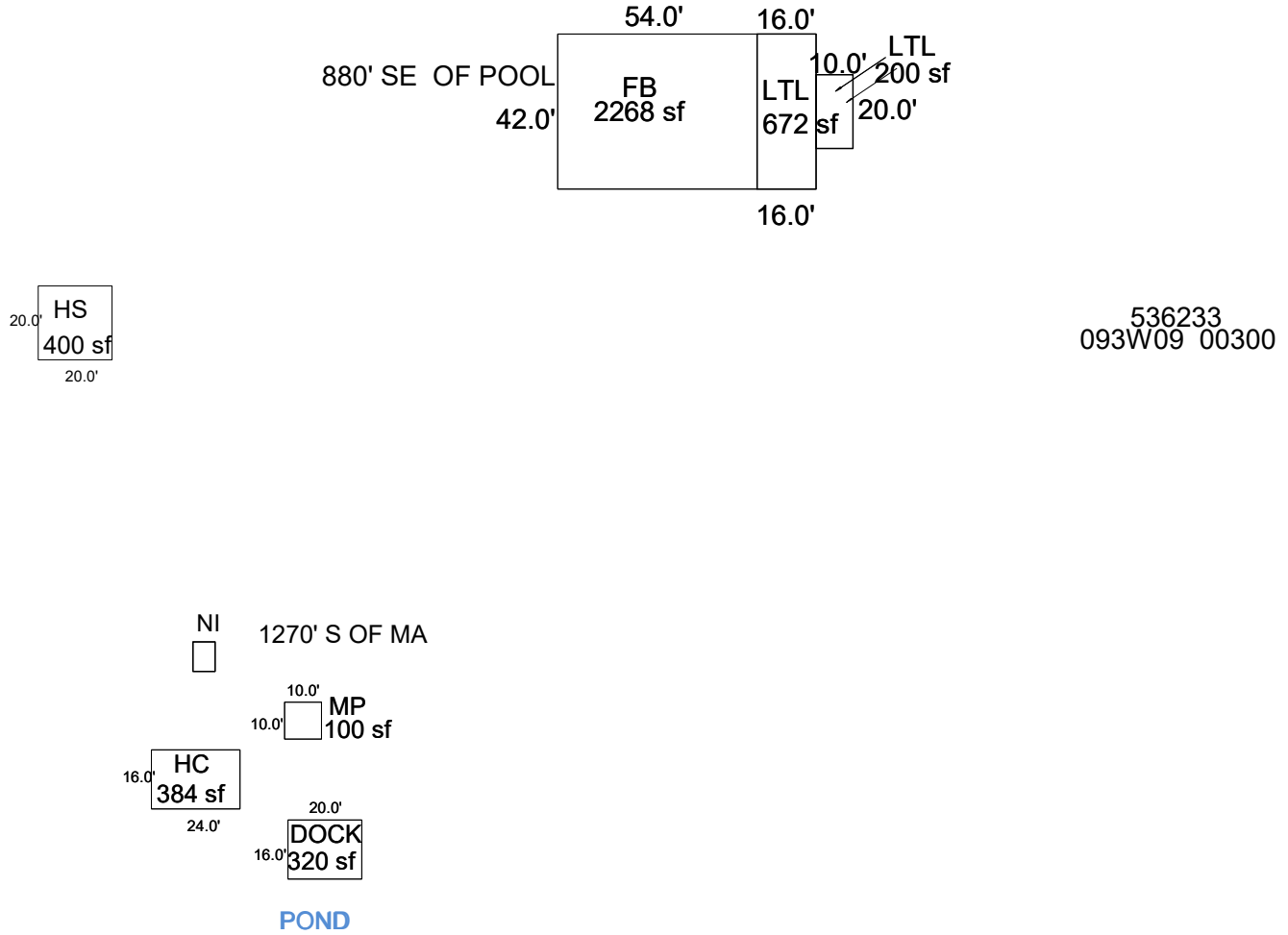

AREA CALCULATIONS SUMMARY

COMMENT TABLE 1

Code	Description	Factor	Net Size	Perimeter	Net Totals
GBA5	LTL	1	200	60	
	LTL	1	672	116	
	LTL	1	200	60	
	LTL	1	672	116	1744
OTH	DOCK	1	320	72	
	HC	1	384	80	
	MP	1	100	40	
	FB	1	2268	192	
	DOCK	1	320	72	
	HC	1	384	80	
	MP	1	100	40	
	FB	1	2268	192	
	HS	1	400	80	6544
	Net BUILDING	cnt	4 (rounded)		1,744

Apex by JA 11/17/09
 UPD BY WW 5.6.24

COMMENT TABLE 2

COMMENT TABLE 3