

Summary Lead Appr: Clerk: Lead Clerk: Appr: MDL Inlet 7/17/25 Print Date: 1/25/2024

Acct ID: 536686 MTL: 093W360000400 Date: 6/17/25 Appr: MDL Prop Class: 551 RMV Prop Class: 551

Situs: 14631 JEFFERSON HWY 99E SE JEFFERSON OR 97352 MaSaNh: 07 06 000 Unit: 56910 Year: 2024 2025

Last Date Appraised: 07/31/2008 Appraiser: MATT LORD Retag: Y (N) Tag info:

Owner: VICKI D TERHUNE RL T Roll Type: R

Cycle Tag Sales Verification Other: Inspection level: 1 2 (3) 4 LCB TTO INSP AV: 363578

RMV Land: 600560 RMV Imp: 297400 RMV Total: 897960 MAV: 212950 MSAV: 150628 SAV: 437992

Comment:

Notations 25-26 cycle

Table with 3 columns: RP/MS, Code, Description. Row 1: RP, ZONED, FARM EFU ZONED

OSDs

Table with 6 columns: Count, Code, Description, RMV, Code Area, Exception. Row 1: 1, SAA, SA OSD - AVERAGE, 45000, 14530, 0

Land

Site: 2 Code Area: 14530 Size: 1.00 Acres Use Code: 005 Zone: REST SAV Use: 011 Exception: 0
Class: Value Source: Farm Homesite Description: RMV: 4690 Exception: Y N
Adjustment(s): GSOIL, IRR Fire Patrol: Description:
Comments: Liability year - 2009 / 81400130

Site: 3 Code Area: 14530 Size: 90.00 Acres Use Code: 005 Zone: REST SAV Use: 011 Exception: 0
Class: 2BISS Value Source: Farm Use - EFU Description: TWO BENCH IRR SOUTH SPECIAL RMV: 485810 Exception: Y N
Adjustment(s): GSOIL, IRR Fire Patrol: Description:
Comments: Liability year - 1980 / 81400130 //05-06: PER #39, CHG OF SOIL CLASS FROM DRY TO IRR

Site: 4 Code Area: 14530 Size: 13.20 Acres Use Code: 005 Zone: REST SAV Use: 011 Exception: 0
Class: 4BISS Value Source: Farm Use - EFU Description: FOUR BENCH IRR SPECIAL SOUTH RMV: 65060 Exception: Y N
Adjustment(s): GSOIL, IRR Fire Patrol: Description:
Comments: Liability year - 1980 / 81400130 //05-06: PER #39, CHG OF SOIL CLASS FROM DRY TO IRR

Improvements - Residence / Manufactured Structures

Bldg: 1 Code Area: 14530 Stat Class: 144 Year Blt: 1932 Eff Year Blt: 1932 Sq.Ft: 2113 % Complete: 100
Desc: Multi Story above grade with basement Dimensions: RMV: 239730
Func Obsc: 100 Econ %: 100 Other %: 100 Exception: 0 Adjust: Adjust RMV: 0

Floors

Table with 10 columns: Type, Class, Display Group, Floor Size, Beds, Baths, Yr Blt, Eff Yr Blt, Inventory, Exception. Rows for First Floor, Attic, Basement.

Accessories

Table with 6 columns: Description, Class, Size SqFt, Eff Yr Blt, RMV, Quantity. Rows for ENCLOSED PORCH, YARD IMPROVEMENTS AVERAGE.

Bldg: 2 Code Area: 14530 Stat Class: 138 Year Blt: 1932 Eff Year Blt: 1932 Sq.Ft: 0 % Complete: 100
Desc: Res other improvements Dimensions: RMV: 17330
Func Obsc: 100 Econ %: 100 Other %: 100 Exception: 0 Adjust: Adjust RMV: 0

Floors

Table with 10 columns: Type, Class, Display Group, Floor Size, Beds, Baths, Yr Blt, Eff Yr Blt, Inventory, Exception. Row for Garage Detached.

Accessories

Table with 6 columns: Description, Class, Size SqFt, Eff Yr Blt, RMV, Quantity. Row: No accessory data available

Improvements - Accessory Buildings

Bldg: 3 Code Area: 14530 Stat Class: 341 Year Blt: 1960 Eff Year Blt: 1960 Sq.Ft: 480 % Complete: 100
Desc: Multi Purpose Shed (MP) Dimensions: 40x12 RMV: 2150
Func Obsc: 100 Econ %: 100 Other %: 100 Exception: 0 Adjust: Adjust RMV: 0

Floors

Type	Class	Display Group	Floor Size	Beds	Baths	Yr Blt	Eff Yr Blt	Inventory	
Multi-Purpose Bldg	5	Finished	480	0	0	1960	1960	FAIR	Exception: Y N

Accessories

Description	Class	Size SqFt	Eff Yr Blt	RMV	Quantity
No accessory data available					

Bldg: 4	Code Area: 14530	Stat Class: 341	Year Blt: 1960	Eff Year Blt: 1960	Sq.Ft: 218	% Complete: 100
Desc: Multi Purpose Shed (MP)			Dimensions: 18x12			RMV: 1140
Func Obsc: 100	Econ %: 100	Other %: 100	Exception: 0	Adjust:	Adjust RMV: 0	

Floors

Type	Class	Display Group	Floor Size	Beds	Baths	Yr Blt	Eff Yr Blt	Inventory	
Multi-Purpose Bldg	5	Finished	218	0	0	1960	1960	FAIR	Exception: Y N

Accessories

Description	Class	Size SqFt	Eff Yr Blt	RMV	Quantity
No accessory data available					

Bldg: 5	Code Area: 14530	Stat Class: 354	Year Blt: 1964	Eff Year Blt: 1964	Sq.Ft: 1184	% Complete: 100
Desc: Lean-to Light (LTL)			Dimensions: 74x16			RMV: 1280
Func Obsc: 100	Econ %: 100	Other %: 100	Exception: 0	Adjust:	Adjust RMV: 0	

Floors

Type	Class	Display Group	Floor Size	Beds	Baths	Yr Blt	Eff Yr Blt	Inventory	
Lean-to Light Duty	4	Finished	1184	0	0	1964	1964	FAIR	Exception: Y N

Accessories

Description	Class	Size SqFt	Eff Yr Blt	RMV	Quantity
No accessory data available					

Bldg: 6	Code Area: 14530	Stat Class: 313	Year Blt: 1974	Eff Year Blt: 1974	Sq.Ft: 2800	% Complete: 100
Desc: Free Stall Barn (SB) <i>GB</i>			Dimensions: 100x28			RMV: 12880
Func Obsc: 100	Econ %: 100	Other %: 100	Exception: 0	Adjust:	Adjust RMV: 0	

Floors

Type	Class	Display Group	Floor Size	Beds	Baths	Yr Blt	Eff Yr Blt	Inventory	
Free Stall Barn	5	Finished	2800	0	0	1974	1974	FAIR	Exception: Y N

Accessories

Description	Class	Size SqFt	Eff Yr Blt	RMV	Quantity
No accessory data available					

Bldg: 7	Code Area: 14530	Stat Class: 353	Year Blt: 1970	Eff Year Blt: 1970	Sq.Ft: 3364	% Complete: 100
Desc: Machine Shed (MS)			Dimensions: 58x58			RMV: 5380
Func Obsc: 100	Econ %: 100	Other %: 100	Exception: 0	Adjust:	Adjust RMV: 0	

Floors

Type	Class	Display Group	Floor Size	Beds	Baths	Yr Blt	Eff Yr Blt	Inventory	
Machine Shed	4	Finished	3364	0	0	1970	1970	<i>Fair</i>	Exception: Y N

Accessories

Description	Class	Size SqFt	Eff Yr Blt	RMV	Quantity
No accessory data available					

Bldg: 8	Code Area: 14530	Stat Class: 355	Year Blt: 1974	Eff Year Blt: 1974	Sq.Ft: 4025	% Complete: 100
Desc: Lean-to Heavy (LTH)			Dimensions: 115x35			RMV: 6520
Func Obsc: 100	Econ %: 100	Other %: 100	Exception: 0	Adjust:	Adjust RMV: 0	

Floors

Type	Class	Display Group	Floor Size	Beds	Baths	Yr Blt	Eff Yr Blt	Inventory	
Lean-to Heavy Duty	4	Finished	4025	0	0	1974	1974	FAIR	Exception: Y N

Accessories

Description	Class	Size SqFt	Eff Yr Blt	RMV	Quantity
No accessory data available					

Bldg: 9	Code Area: 14530	Stat Class: 312	Year Blt: 1964	Eff Year Blt: 1964	Sq.Ft: 3404	% Complete: 100
Desc: Loft Barn (LB)			Dimensions: 74x46			RMV: 10290
Func Obsc: 50	Econ %: 100	Other %: 100	Exception: 0	Adjust:	Adjust RMV: 0	

Floors

Type	Class	Display Group	Floor Size	Beds	Baths	Yr Blt	Eff Yr Blt	Inventory	
Loft Barn	5	Finished	3404	0	0	1964	1964	FAIR	Exception: Y N

Accessories

Description	Class	Size SqFt	Eff Yr Blt	RMV	Quantity
No accessory data available					

Bldg: 10 Code Area: 14530 Stat Class: 341 Year Blt: 1964 Eff Year Blt: 1964 Sq.Ft: 140 % Complete: 100
 Desc: Multi Purpose Shed (MP) Dimensions: 14x10 RMV: 700
 Func Obsc: 100 Econ %: 100 Other %: 100 Exception: 0 Adjust: Adjust RMV: 0

Floors

Type	Class	Display Group	Floor Size	Beds	Baths	Yr Blt	Eff Yr Blt	Inventory	
Multi-Purpose Bldg	5	Finished	140	0	0	1964	1964		Exception: Y N

Accessories

Description	Class	Size SqFt	Eff Yr Blt	RMV	Quantity
No accessory data available					

SKETCH/AREA TABLE ADDENDUM

SUBJECT INFO

File No.: 536686 Parcel No.: 093W 36 00400
 Property Address: 14631 Jefferson Hwy 99E se
 City: Jefferson County: State: OR ZipCode: 97352
 Owner:
 Client: Client Address:
 Appraiser Name: Inspection Date:

SKETCH

536686
093W 36 00400

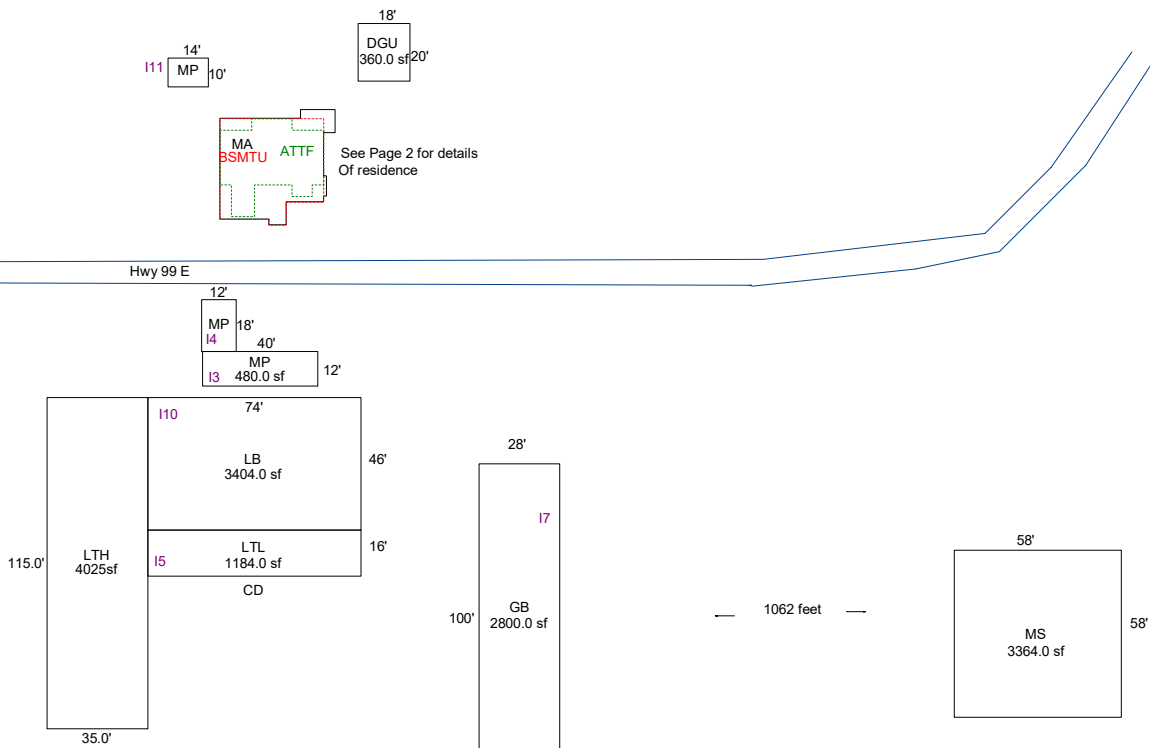

Sketch by ApexSketch

AREA CALCULATIONS SUMMARY						COMMENT TABLE 1	
Code	Description	Factor	Net Size	Perimeter	Net Totals		
GBA1	MP	1.0	140.0	48.0		Apex 3/15/2011 UPDATED BY CLOBERG 09/23/25	
	LB	1.0	3404.0	240.0			
	MP	1.0	480.0	104.0			
	MP	1.0	216.0	60.0			
	LTL	1.0	1184.0	180.0			
	GB	1.0	2800.0	256.0			
	LTH	1.0	4025.0	300.0	15613.0		
GLA1	MA	1.0	1257.0	162.0	1257.0	COMMENT TABLE 2 MDL 06/17/25	
GLA2	ATTF	1.0	856.0	148.0	856.0		
BSMT	BSMTU	1.0	1194.0	146.0	1194.0		
GAR	DGU	1.0	360.0	76.0	360.0		
	Net LIVABLE	cnt	0	(rounded)	2,113		
	Net BUILDING	cnt	8	(rounded)	15,613		



R36686
093W 36 00400
N

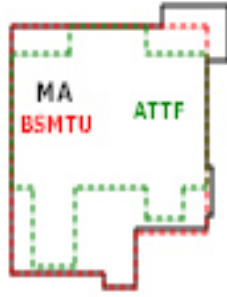

See Page 2 for details
Of residence

Hwy 99 E

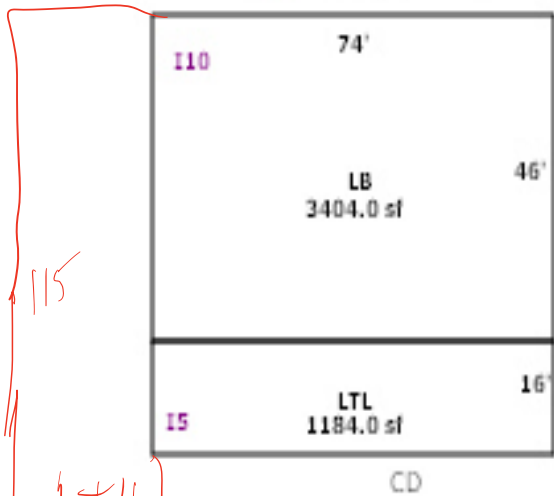
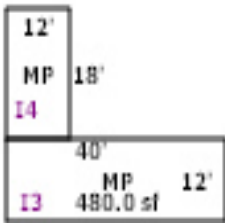

115
LTH
35

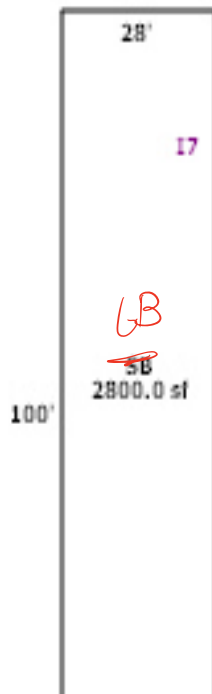

1062 feet

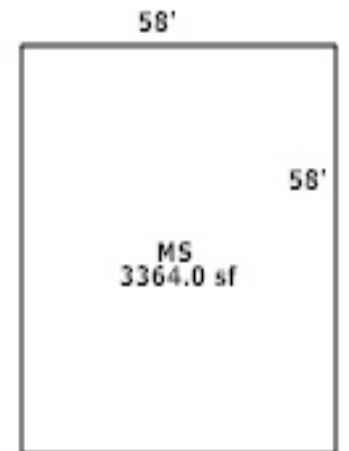

R36686
093W 36 00400
2 of 2

