

Acct ID: 536734 MTL: 094W130001300 Date: 6/17/25 Appr: MDL Prop Class: 451 RMV Prop Class: 451
 Situs: 3903 BUENA VISTA RD S JEFFERSON OR 97352 MaSaNh: 07 06 000 Unit: 70263 Year: ~~2024~~ 2025
 Last Date Appraised: 08/16/2018 Appraiser: MATT LORD Retag: Y N Tag info: _____
 Owner: VINCENT, ROBERT KEEVER Roll Type: R
 Cycle Tag Sales Verification Other: _____ Inspection level: 1 2 3 4 LCB TTO INSP AV: 231000
 RMV Land: 220900 RMV Imp: 294230 RMV Total: 515130 MAV: 231000 MSAV: 0 SAV: 0
 Comment: _____

Notations 25-26 cycle
 No notation data available.

OSDs

Count	Code	Description	RMV	Code Area	Exception
1	MKTA	OSD - AVERAGE	45000	14530	0

Land

Site: 1 Code Area: 14530 Size: 0.77 Acres Use Code: 005 Zone: REST SAV Use: _____ Exception: 0
 Class: 2BDS Value Source: Rural Restrictive Description: TWO BENCH DRY SOUTH SPECIAL RMV: 175900 Exception: Y N
 S
 Adjustment(s): GSOIL Fire Patrol: _____ Description: _____
 Comments: 08-09: MAP ROOM CORRECTION OF ACREAGE FROM 1 TO .77// 2003-04 REAPPRAISAL.

Improvements - Residence / Manufactured Structures

Bldg: 1 Code Area: 14530 Stat Class: 132 + Year Blt: 1910 Eff Year Blt: 1980 Sq.Ft: 2184 % Complete: 100
 Desc: Multi Story above grade Dimensions: _____ RMV: 273230
 Func Obsc: 100 Econ %: 100 Other %: 100 Exception: 0 Adjust: _____ Adjust RMV: 0

Floors

Type	Class	Display Group	Floor Size	Beds	Baths	Yr Blt	Eff Yr Blt	Inventory	Exception
First Floor	3 +	Finished	1480	0	FB-2	1910	1980	HVAC, FP - 1, ROOF, KIT, BATH - 2	Y N
Second Floor	3 +	Finished	704	3	0	1910	1980	HVAC	Y N
Garage Detached	4	Finished	864	0	0	2004	2004	ROOF	Y N

Accessories Move to own level

Description	Class	Size SqFt	Eff Yr Blt	RMV	Quantity
No accessory data available					

Bldg: 2 Code Area: 14530 Stat Class: 107 Year Blt: _____ Eff Year Blt: _____ Sq.Ft: 0 % Complete: 100
 Desc: Yard Improvements Dimensions: _____ RMV: 21000
 Func Obsc: 100 Econ %: 100 Other %: 100 Exception: 0 Adjust: _____ Adjust RMV: 0

Floors

Type	Class	Display Group	Floor Size	Beds	Baths	Yr Blt	Eff Yr Blt	Inventory	Exception
No floor data available									

Accessories

Description	Class	Size SqFt	Eff Yr Blt	RMV	Quantity	Exception
YARD IMPROVEMENTS GOOD	4	0	0	21000	1	Y N

Improvements - Accessory Buildings

No improvement data available for all other stat class types.

SKETCH/AREA TABLE ADDENDUM

SUBJECT INFO

File No.: 536734 Parcel No.: 094W13 01300
 Property Address: 3903 BUENA VISTA RD S
 City: JEFFERSON County: State: OR ZipCode: 97352
 Owner:
 Client: Client Address:
 Appraiser Name: Inspection Date:

SKETCH

536734
094W13 01300
SCALE=1:20

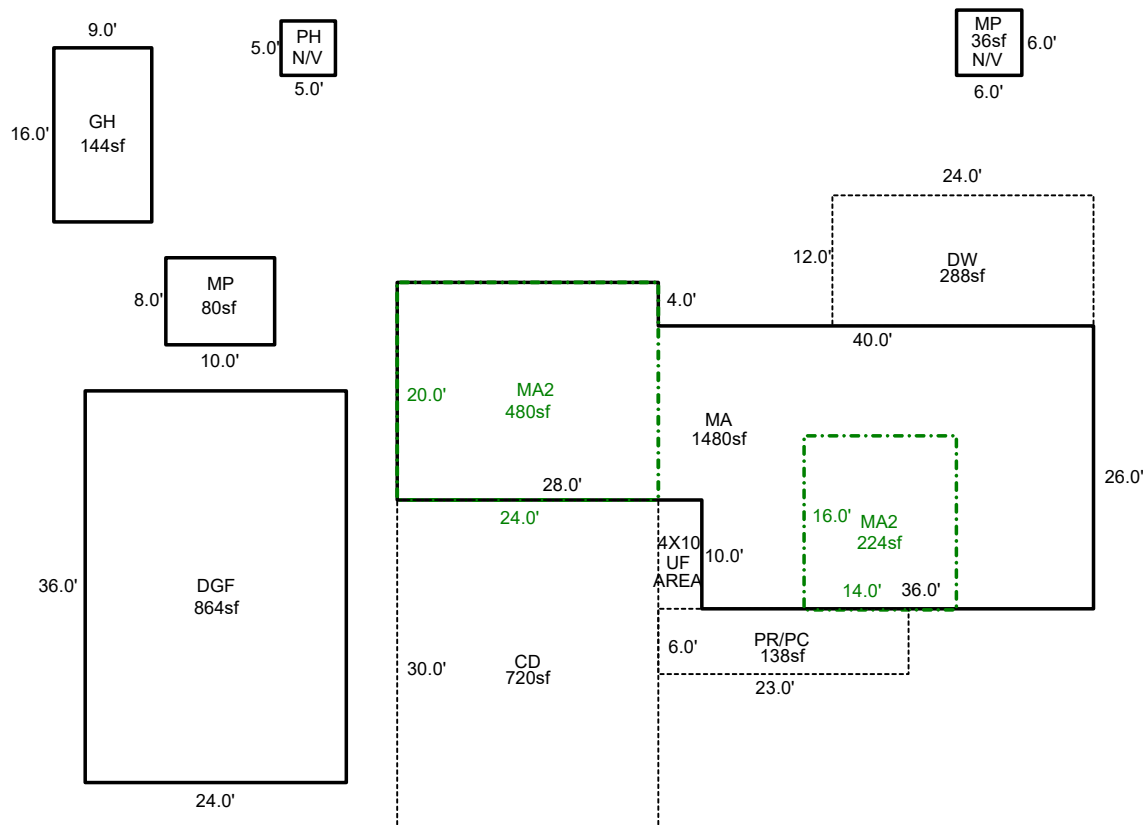

Sketch by ApexSketch

AREA CALCULATIONS SUMMARY						COMMENT TABLE 1	
Code	Description	Factor	Net Size	Perimeter	Net Totals		
GBA1	MP	1.0	36.0	24.0		APEXED BY NRC 04/23/2009 UPDATED BY JRONDEMA 8/17/18 UPDATED BY CLOBERG 08/21/25	
	GH	1.0	144.0	50.0			
	MP	1.0	80.0	36.0	260.0		
GLA1	MA	1.0	1480.0	188.0	1480.0		
GLA2	MA2	1.0	480.0	88.0			
	MA2	1.0	224.0	60.0	704.0		
GAR P/P	DGF	1.0	864.0	120.0	864.0		
	CD	1.0	720.0	108.0			
	PR/PC	1.0	138.0	58.0			
	DW	1.0	288.0	72.0	1146.0	COMMENT TABLE 2	COMMENT TABLE 3
						MDL 06/17/25	CYCLE L3
	Net LIVABLE	cnt	0 (rounded)		2,184		
	Net BUILDING	cnt	3 (rounded)		260		

R36734
094W13 01300
SCALE=1:20

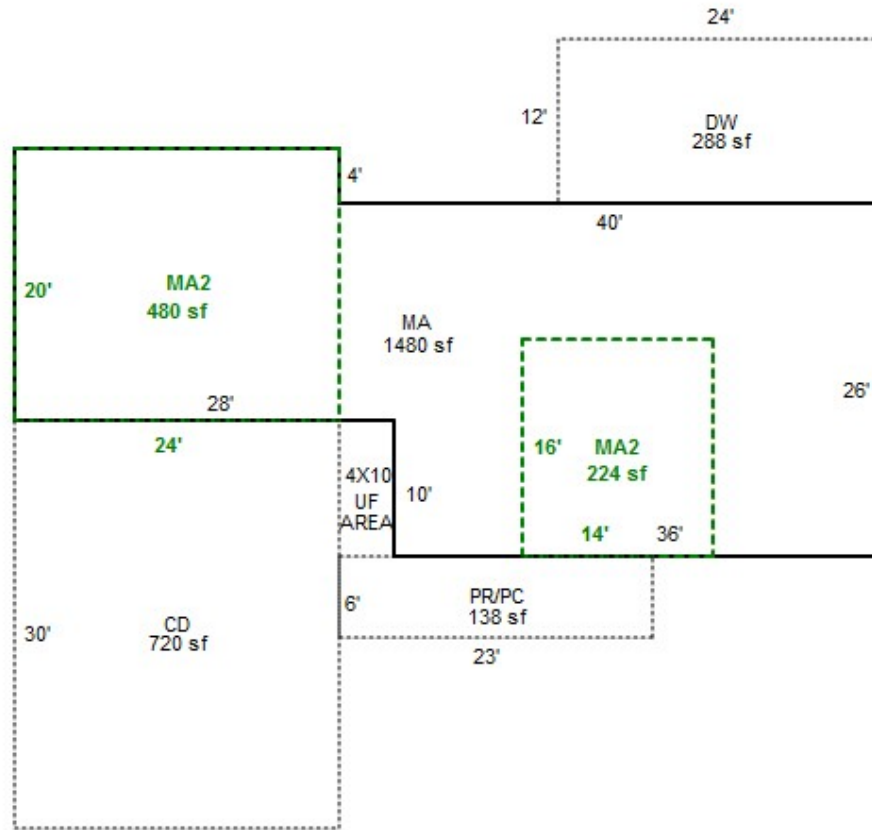
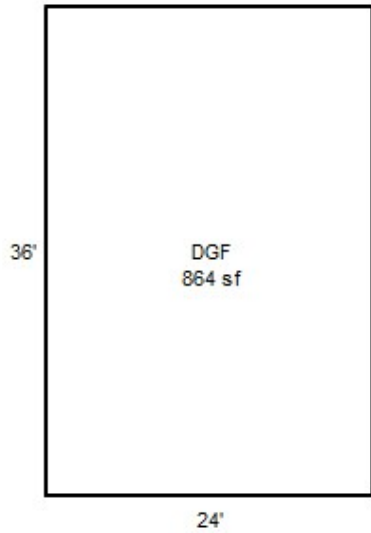
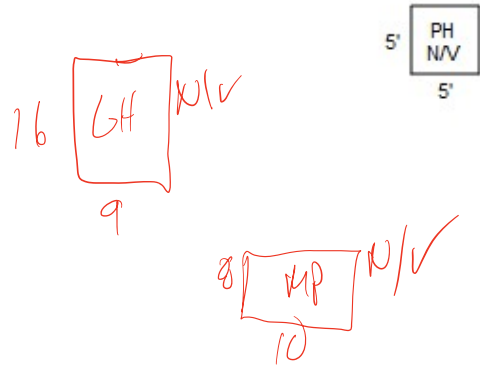

094W13 01300

R36734

SCALE 1/25

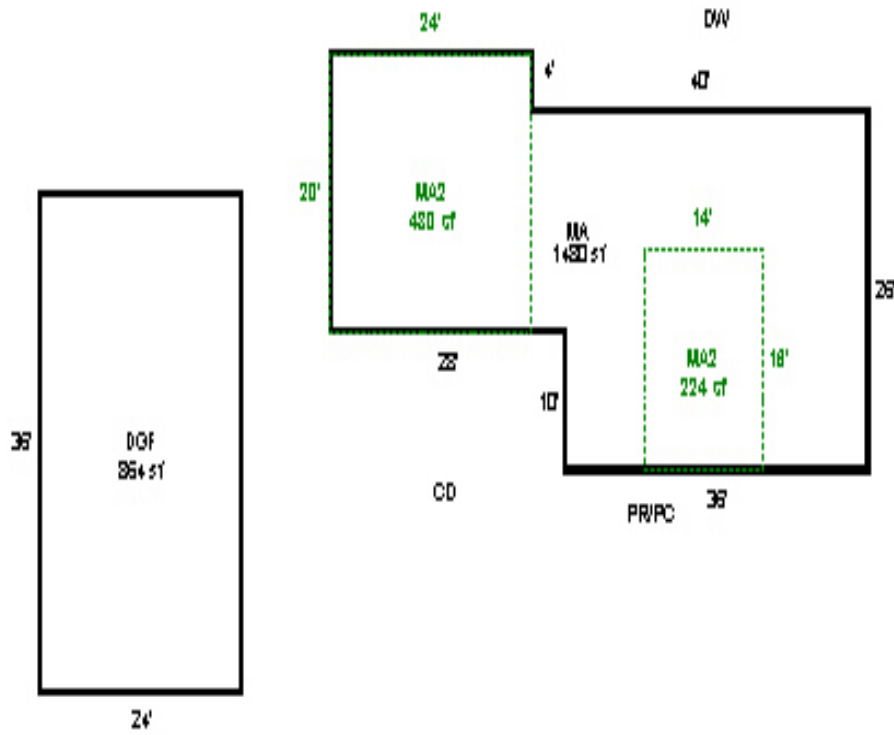

BUENA VISTA RD S



R36734 DGF back
8/16/2018



R36734 DGF
8/16/2018



R36734 MA Back R
8/16/2018



R36734 MA
8/16/2018



R36734 PH NV
8/16/2018



