

SKETCH/AREA TABLE ADDENDUM

SUBJECT INFO

File No.: 331172 Parcel No.: 072W05BA19300
 Property Address: 4927 MIDLAND CT NE
 City: SALEM County: State: OR ZipCode: 97305
 Owner:
 Client: Client Address:
 Appraiser Name: Inspection Date:

SKETCH

331172
072W05BA19300

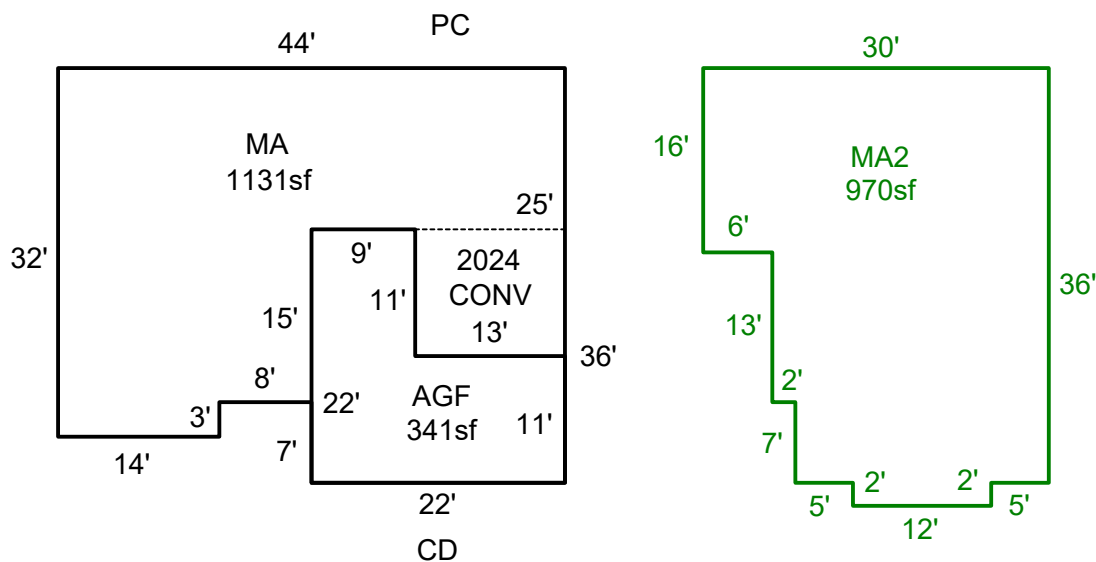

Sketch by ApexSketch

AREA CALCULATIONS SUMMARY						COMMENT TABLE 1	
Code	Description	Factor	Net Size	Perimeter	Net Totals		
GLA1	MA	1.0	1131.0	166.0	1131.0	DRAWN BY TB 11/03/08 Updated by AE 9.6.24 Updated by AE 10.13.25	
GLA2	MA2	1.0	970.0	136.0	970.0		
GAR	AGF	1.0	341.0	88.0	341.0		
Net LIVABLE		cnt	2 (rounded)	2,101		COMMENT TABLE 2	COMMENT TABLE 3
						5/4/18 #72 NV-Cycle	