

# SKETCH/AREA TABLE ADDENDUM

## SUBJECT INFO

File No.: 320499 Parcel No.: 081W35BC01800  
 Property Address: 1150 NE ROSEWOOD ST  
 City: SUBLIMITY County: State: OR ZipCode: 97385  
 Owner:  
 Client: Client Address:  
 Appraiser Name: Inspection Date:

## SKETCH

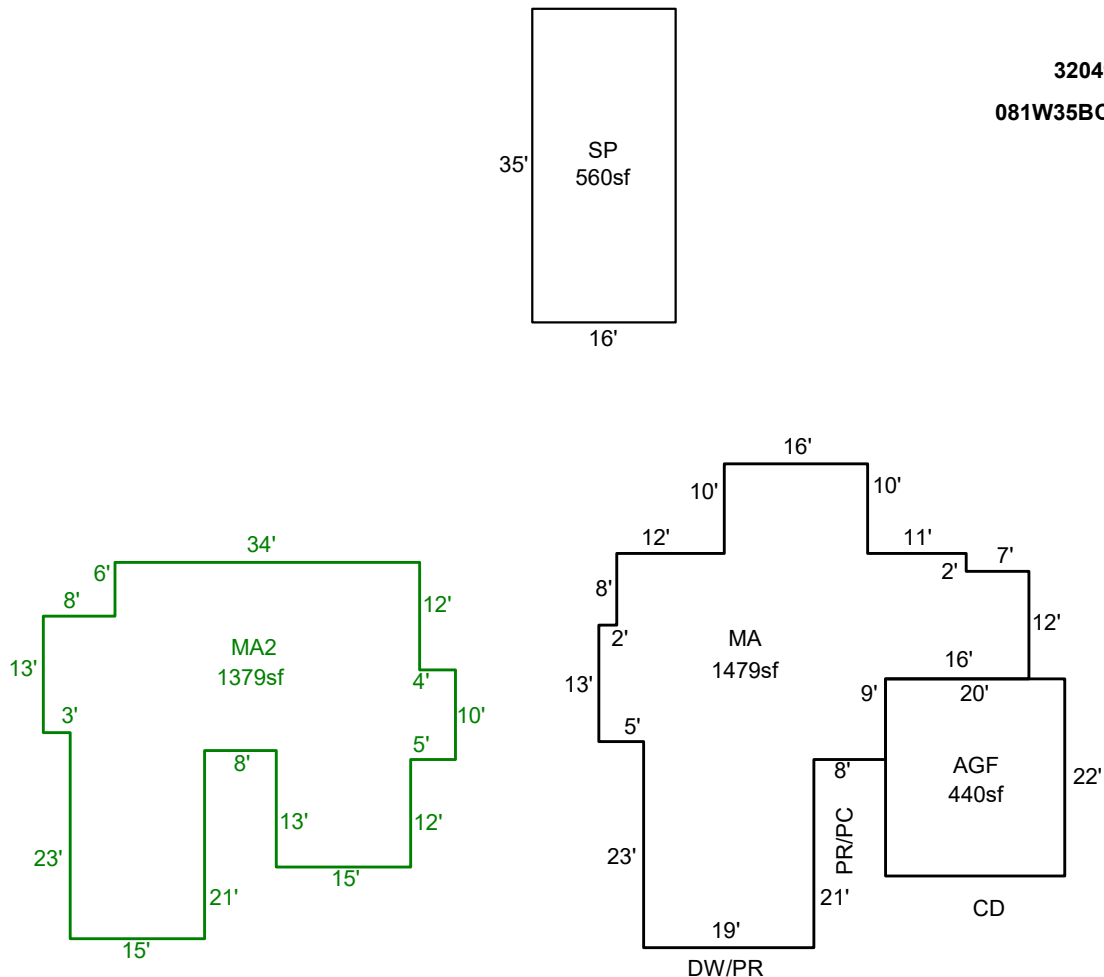

Sketch by ApexSketch

### AREA CALCULATIONS SUMMARY

Code	Description	Factor	Net Size	Perimeter	Net Totals
GLA1	MA	1.0	1479.0	204.0	1479.0
GLA2	MA2	1.0	1379.0	202.0	1379.0
GARAGE	AGF	1.0	440.0	84.0	440.0
OTH	SP	1.0	560.0	102.0	560.0

### COMMENT TABLE 1

DRAWN 08/02/10  
 UPDATED BY LK 10.24.25

### COMMENT TABLE 2

10.10.25 TAG GM

### COMMENT TABLE 3

Net LIVABLE                      cnt                      1      (rounded)                      2,858