

Acct ID: 524552 MTL: 072W35C001700 Date: 10-14-25 Appr: CLIVE Prop Class: 551 RMV Prop Class: 451
 Situs: 1350 74TH AVE SE SALEM OR 97317 MaSaNh: 01 06 000 Unit: 68171 IMPR 10-14-25 Year: 2025

Last Date Appraised: 05/19/2016 Appraiser: CLINT LUKE Tag: Y N Tag info: 2026 - NEW CONSTRUCTION (Addition)
 Owner: REYNOLDS, VALERIE & REYNOLDS, ROBIN Last Sales Date: 11/01/1994 Roll Type: R
 Cycle Tag Sales Verification Other: _____ Inspection level: 1 2 3 4 LCB TTO INSP AV: 300237
 RMV Land: 468560 RMV Imp: 421280 RMV Total: 889840 MAV: 268470 MSAV: 31767 SAV: 65909

Comment: 25-001902 ENCLOSED PERMIT INSURANCE AS OF 10-7-25

Notations

RP/MS	Code	Description
RP	ZONED	FARM EFU ZONED

OSDs

Count	Code	Description	RMV	Code Area	Exception
1	SAA	SA OSD - AVERAGE	50000	92410	0

Land

Site: 2	Code Area: 92410	Size: 1.00 Acres	Use Code: 005	Zone: REST	SAV Use: 011	Exception: 0
Class:	Value Source: Farm Homesite	Description:			RMV: 45900	Exception: Y N
Adjustment(s):	GSOIL	Fire Patrol:		Description:		
Comments: Liability year - 2009 / 2400210 /06-07: INCREASE HOMESITE TO ONE ACRE, ADD EXCEPTION VALUE, NO PAT LIAB WILL BE COLLECTED.						
Site: 3	Code Area: 92410	Size: 7.38 Acres	Use Code: 005	Zone: REST	SAV Use: 011	Exception: 0
Class: 2HD	Value Source: Farm Use - EFU	Description: TWO HILL DRY			RMV: 372660	Exception: Y N
Adjustment(s):	GSOIL	Fire Patrol:		Description:		
Comments: Liability year - 1983 / 2400210						

Improvements - Residence / Manufactured Structures

Bldg: 1	Code Area: 92410	Stat Class: 142	Year Blt: 1997	Eff Year Blt: 1997	Sq.Ft: 2129	% Complete: 100.00
Desc: Multi Story above grade			Dimensions:		RMV: 394890	
Func Obsc: 100	Econ %: 100	Other %: 100	Exception: 0	Adjust:	Adjust RMV: 0	

Floors

Type	Class	Display Group	Floor Size	Beds	Baths	Yr Blt	Eff Yr Blt	Inventory	Exception
First Floor	4	Finished	1817	3	FB-2/ HB-1	1997	1997	BTH - 1, KIT+ HVAC+ ROOF, BATH - 2	Y N
Attic	4	Low Cost	312	0	0	1997	1997	HVAC	Y N
Garage Attached	4	Finished	702	0	0	1997	1997	ROOF	Y N

Accessories

Description	Class	Size SqFt	Eff Yr Blt	RMV	Quantity	Exception
YARD IMPROVEMENTS AVERAGE <u>GOOD</u>	4	1	1997	27927	1	Y N

Bldg: 5	Code Area: 92410	Stat Class: 108	Year Blt: 2004	Eff Year Blt: 2004	Sq.Ft: 0	% Complete: 100.00
Desc: Residential Other Improvements			Dimensions:		RMV: 12030	
Func Obsc: 100	Econ %: 100	Other %: 100	Exception: 0	Adjust:	Adjust RMV: 0	

Floors

Type	Class	Display Group	Floor Size	Beds	Baths	Yr Blt	Eff Yr Blt	Inventory	Exception
No floor data available									

Accessories

Description	Class	Size SqFt	Eff Yr Blt	RMV	Quantity	Exception
ASPHALT DRIVEWAY	1	5043	2004	11346	1	Y N

Improvements - Accessory Buildings

Bldg: 2	Code Area: 92410	Stat Class: 351	Year Blt: 1985	Eff Year Blt: 1985	Sq.Ft: 2592	% Complete: 100.00
Desc: General Purpose Building (GB)			Dimensions: 72x36		RMV: 11390	
Func Obsc: 100	Econ %: 100	Other %: 100	Exception: 0	Adjust:	Adjust RMV: 0	

Floors

Type	Class	Display Group	Floor Size	Beds	Baths	Yr Blt	Eff Yr Blt	Inventory	Exception
General Purpose Bldg	5	Finished	2592	0	0	1985	1985	FAIR	Y N

Accessories

Description	Class	Size SqFt	Eff Yr Blt	RMV	Quantity	Exception
No accessory data available						

Bldg: 3 Code Area: 92410 Stat Class: 353 Year Blt: 1985 Eff Year Blt: 1985 Sq.Ft: 288 ⁵¹² % Complete: 100.00
 Desc: Machine Shed (MS) Dimensions: 22x26 RMV: 740
 Func Obsc: 100 Econ %: 100 Other %: 100 Exception: 0 Adjust: ^{22x26} Adjust RMV: 0

Floors

Type	Class	Display Group	Floor Size	Beds	Baths	Yr Blt	Eff Yr Blt	Inventory	Exception: Y N
Machine Shed	4	Finished	288	0	0	1985	1985	50% FAIR	

Accessories

Description	Class	Size SqFt	Eff Yr Blt	RMV	Quantity
No accessory data available					

Bldg: 4 Code Area: 92410 Stat Class: 341 Year Blt: 1996 Eff Year Blt: 1996 Sq.Ft: 288 ⁵²⁴ % Complete: 100.00
 Desc: Multi Purpose Shed (MS) ^{MS} Dimensions: 12x24 ³² RMV: 2230
 Func Obsc: 100 Econ %: 100 Other %: 100 Exception: 0 Adjust: ^{+10x14} Adjust RMV: 0

Floors

Type	Class	Display Group	Floor Size	Beds	Baths	Yr Blt	Eff Yr Blt	Inventory	Exception: Y N
Multi Purpose Bldg	5	Finished	288	0	0	1996	1996	60% ANE	

Accessories

Description	Class	Size SqFt	Eff Yr Blt	RMV	Quantity
No accessory data available					

Permits

Permit Number	Permit ID	Origin	Category	Type	Estimate Value	% Complete	Roll Type	Description
25-001902	83436	MARION COUNTY	NEW CONSTRUCTION	ADDITION	19000	0	R	Enclosing a covered porch to add approx. 170ft^2 of livable space under an existing roof line.

SKETCH/AREA TABLE ADDENDUM

SUBJECT INFO

File No.: 524552 Parcel No.: 072W 35C 01700
 Property Address: 1350 74th Ave SE
 City: Salem County: State: OR ZipCode: 97317
 Owner:
 Client: Client Address:
 Appraiser Name: Inspection Date:

SKETCH

524552
072W 35C 01700

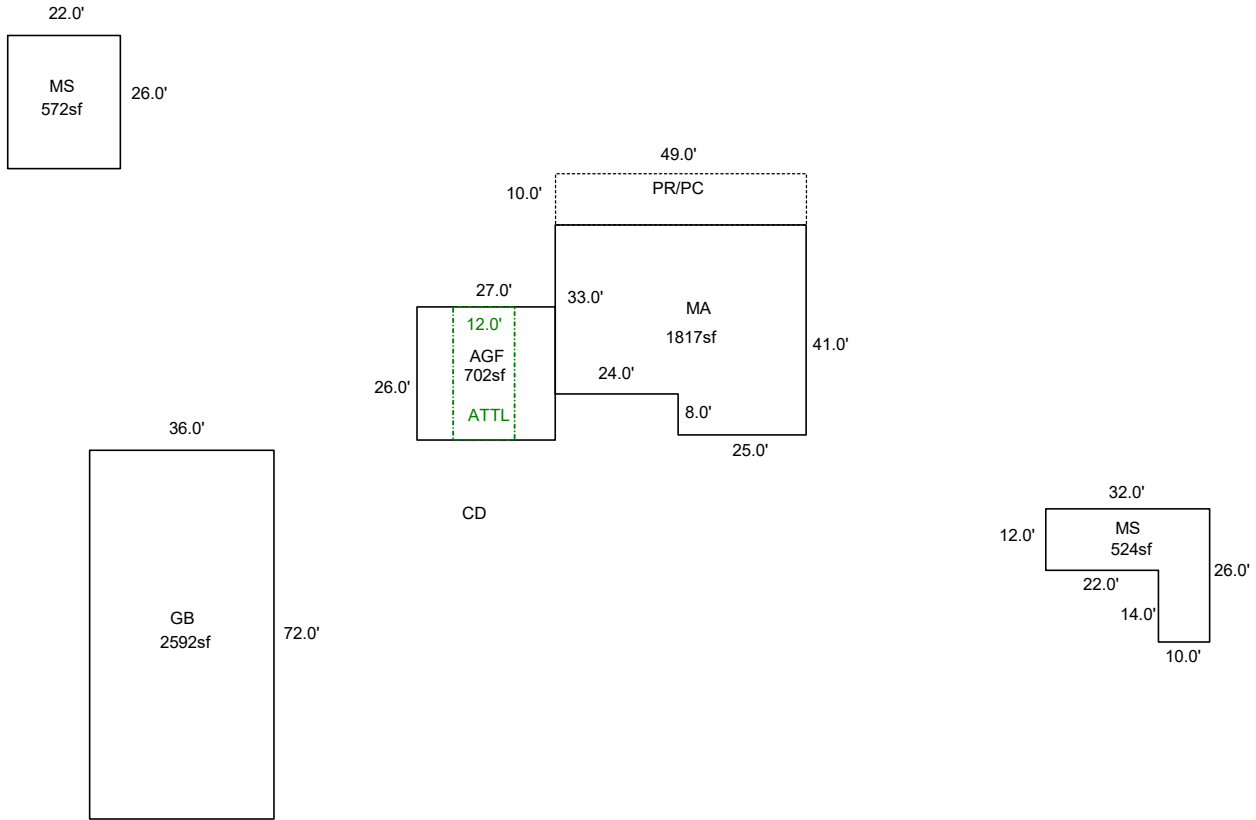

Sketch by ApexSketch

AREA CALCULATIONS SUMMARY

Code	Description	Factor	Net Size	Perimeter	Net Totals
GBA1	GB	1.0	2592.0	216.0	
	MS	1.0	572.0	96.0	
	MS	1.0	524.0	116.0	3688.0
GLA1	MA	1.0	1817.0	180.0	1817.0
GLA2	ATTL	1.0	312.0	76.0	312.0
GAR	AGF	1.0	702.0	106.0	702.0
P/P	PR/PC	1.0	490.0	118.0	490.0

COMMENT TABLE 1

Apex 5/27/2011 Jane
 UPDATED BY CLOBERG 05/07/25 25-001902 MA ADDN
 UPDATED BY CLOBERG 10/16/25

COMMENT TABLE 2

CLUKE 10/14/25

COMMENT TABLE 3

TAGS L4

Net LIVABLE	cnt	0	(rounded)		2,129
Net BUILDING	cnt	3	(rounded)		3,688