

Summary

Lead Appr: WW 11/18 Clerk: Lead Clerk: Appr: Print Date: 9/26/2025

Acct ID: 529260 MTL: 082W02C001200 Date: 11-4-25 Appr: [Signature] Prop Class: 401 RMV Prop Class: 401
Situs: 2428 74TH AVE SE SALEM OR 97317 MaSaNh: 01 06 004 Unit: 54238 Year: 2025

Last Date Appraised: 12/12/2024 Appraiser: CLINT LUKE Tag: Y N Tag info: 2026 - Tags/Permit (Completion) [Signature]

Owner: KIPSCH, KEVIN J Last Sales Date: 11/05/2004 Roll Type: R

Cycle: Tag Sales Verification Other: Inspection level: 1 2 3 4 LCB TTO INSP AV: 226220

RMV Land: 273630 RMV Imp: 317910 RMV Total: 591540 MAV: 226220 MSAV: 0 SAV: 0

Comment: 25-26 L2 12/12/24 CLUKE
24-25: L2 10.26.23 GRH
23-24: L2 01.20.23 MLH//22-23: L2 09.21.21 CL
LEVEL 2 1.14.21 CL10

NO CHANGE

20-004095 EXPIRED 7-27-24
LAST INSP 1/4/21

OSDs

Count	Code	Description	RMV	Code Area	Exception
1	MKTA	OSD - AVERAGE	50000	92410	0

Land

Site: 1 Code Area: 92410 Size: 1.00 Acres Use Code: 004 Zone: NREST SAV Use: Exception: 0
Class: 2BDSS Value Source: Rural at MKT Description: TWO BENCH DRY SOUTH SPECIAL RMV: 223630 Exception: Y N
Adjustment(s): GSOIL Fire Patrol: Description:
Comments: 02-03: REAPPRAISAL //04-05: LAND ADJUSTMENT PROJECT FOR RECALCULATION BY #31

Improvements - Residence / Manufactured Structures

Bldg: 1 Code Area: 92410 Stat Class: 131 + Year Blt: 2014 Eff Year Blt: 2014 Sq.Ft: 2034 % Complete: 100.00
Desc: One Story Only Dimensions: RMV: 278970
Func Obsc: 100 Econ %: 100 Other %: 100 Exception: 0 Adjust: Adjust RMV: 0

Floors

Type	Class	Display Group	Floor Size	Beds	Baths	Yr Blt	Eff Yr Blt	Inventory	Exception
First Floor	3 +	Finished	900	3	FB-2	2014	2014	HVAC, ROOF, KIT-, BATH - 2	Y N
First Floor	78%	3 +	Finished	1134	0	0	2014	2014	Y N
Garage Attached	50%	3 +	Finished	910	0	0	2021	2021	ROOF Y N

Accessories

Description	Class	Size SqFt	Eff Yr Blt	RMV	Quantity
YARD IMPROVEMENTS FAIR	3	0	2014	10165	1

Improvements - Accessory Buildings

Bldg: 2 Code Area: 92410 Stat Class: 341 Year Blt: 1970 Eff Year Blt: 1970 Sq.Ft: 182 % Complete: 100.00
Desc: Multi Purpose Shed (MP) Dimensions: 14x13 RMV: 990
Func Obsc: 100 Econ %: 100 Other %: 100 Exception: 0 Adjust: Adjust RMV: 0

Floors

Type	Class	Display Group	Floor Size	Beds	Baths	Yr Blt	Eff Yr Blt	Inventory	Exception
Multi-Purpose Bldg	5	Finished	182	0	0	1970	1970	FAIR	Y N

Accessories

Description	Class	Size SqFt	Eff Yr Blt	RMV	Quantity
No accessory data available					

Bldg: 3 Code Area: 92410 Stat Class: 351 Year Blt: 2007 Eff Year Blt: 2007 Sq.Ft: 2880 % Complete: 100.00
Desc: General Purpose Building (GB) Dimensions: 72x40 RMV: 37950
Func Obsc: 100 Econ %: 100 Other %: 100 Exception: 0 Adjust: Adjust RMV: 0

Floors

Type	Class	Display Group	Floor Size	Beds	Baths	Yr Blt	Eff Yr Blt	Inventory	Exception
General Purpose Bldg	5	Finished	2880	0	0	2007	2007	FAIR	Y N

Accessories

Description	Class	Size SqFt	Eff Yr Blt	RMV	Quantity
No accessory data available					

HC 5 20x40 FAIR 1/0
I ADDED IT AS A HC IN 2021 APPA ON 10/26/23 CHANGED TO KCP F'm
CHANGING BACK TO HC



11/4/25

Percent Complete Form

Account # 529260

AGF 50%

Additions

New Homes

		No Basement		Basement	
% Item	% Sum	% Item	% Sum	% Item	% Sum
3%		3%		3%	
2%	0%	2%	0%	4%	0%
3%		3%		10%	
35%	45%	14%	20%	16%	35%
8%	50%	7%	30%	7%	40%
7%	60%	7%	35%	7%	45%
7%	65%	7%	45%	6%	55%
5%	70%	5%	50%	5%	60%
4%	75%	4%	55%	3%	65%
3%	80%	3%	60%	2%	65%
2%		2%		1%	
2%		2%		1%	
3%		3%		2%	
5%	85%	5%	65%	4%	70%
2%	90%	2%	70%	2%	75%
2%		2%		2%	
		6%	75%	5%	80%
2%		3%	80%	2%	85%
2%	95%	4%	85%	3%	85%
3%		7%	90%	6%	90%
2%	100%	7%	95%	6%	95%
		2%	100%	2%	100%
		1%	100%	1%	100%

781

APPR GRH Date 10/26/23 YR For 2024 % COMP 78, 50
 APPR _____ Date _____ YR For _____ % COMP _____
 APPR Devine Date 11-4-25 YR For 25-26 % COMP NC
 APPR _____ Date _____ YR For _____ % COMP _____

Percent Complete Form

Account # _____

Gut & Remodels

Interior Trim Carpentry	7%	90%
Floor Coverings & Countertops	7%	85%
Plumbing Fixtures	4%	80%
Electrical Fixtures	3%	80%
Cabinets	6%	75%
Drywall (Finished)	5%	70%
Insulation	3%	65%

APPR _____ Date _____ YR For _____ % COMP _____
 APPR _____ Date _____ YR For _____ % COMP _____
 APPR _____ Date _____ YR For _____ % COMP _____
 APPR _____ Date _____ YR For _____ % COMP _____

Outbuilding Type: _____

	% Item	% Sum
Excavation/Foundation	10%	40%
Floor - Concrete/Wood	30%	
Walls - Framing	10%	65%
Walls - Covering/Siding	15%	
Roof - Framing/Trusses	15%	
Roof - Sheathing	5%	95%
Roof - Cover	10%	
Doors & Windows	5%	100%

APPR _____ Date _____ YR For _____ % COMP _____
 APPR _____ Date _____ YR For _____ % COMP _____
 APPR _____ Date _____ YR For _____ % COMP _____
 APPR _____ Date _____ YR For _____ % COMP _____

SKETCH/AREA TABLE ADDENDUM

SUBJECT INFO

File No.: 529260 Parcel No.: 082W02C 01200
 Property Address: 2428 74TH AV SE
 City: SALEM County: MARION State: OR ZipCode: 97317
 Owner:
 Client: Client Address:
 Appraiser Name: Inspection Date:

SKETCH

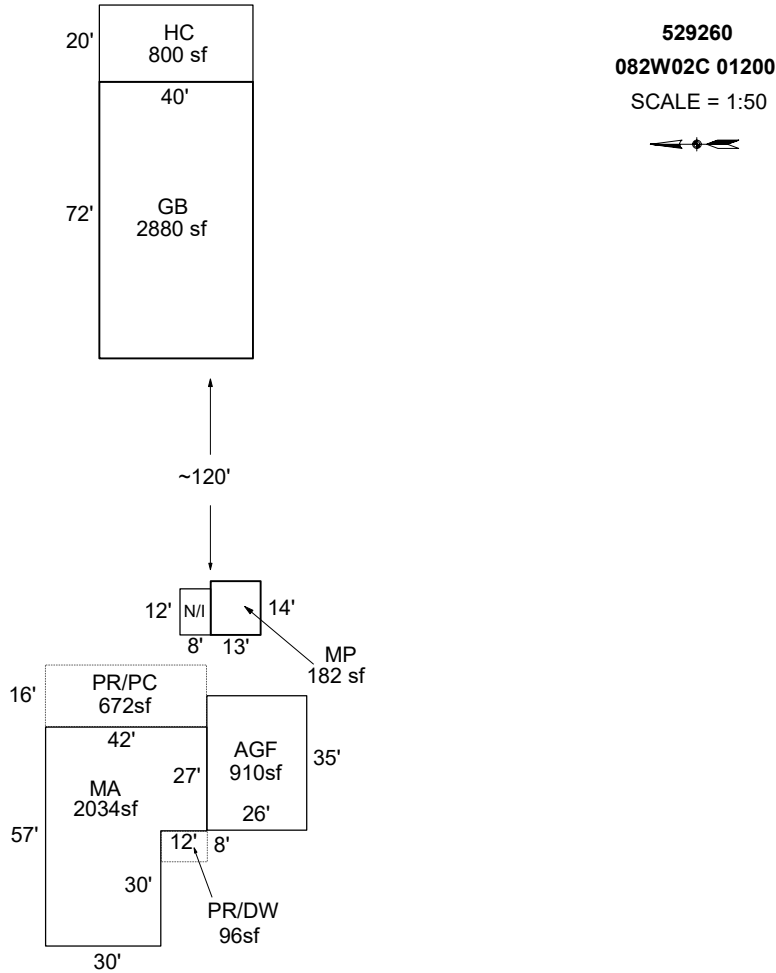

Sketch by ApexSketch

AREA CALCULATIONS SUMMARY

Code	Description	Factor	Net Size	Perimeter	Net Totals
GBA1	MP	1.0	182.0	54.0	
	GB	1.0	2880.0	224.0	3062.0
GLA1	MA	1.0	2034.0	198.0	2034.0
GAR	AGF	1.0	910.0	122.0	910.0
P/P	PR/DW	1.0	96.0	40.0	
	PR/PC	1.0	672.0	116.0	768.0
	Net LIVABLE	cnt	0 (rounded)		2,034
	Net BUILDING	cnt	2 (rounded)		3,062

COMMENT TABLE 1

APEX BY CE 11/5/08
 UPDATED BY SRAGSDALE 1/15/14
 UPDATED BY JRONDEMA 4/28/15
 UPDATED BY JRONDEMA 1/26/18
 UPD BY PHU 12.15.20: 555-20-004095
 UPDATED BY CJURAN 03/13/2023
 UPDATED BY CJURAN 02/29/2024
 UPDATED BY CLOBERG 11/17/25

COMMENT TABLE 2

1/24/18 SR #94 TAGS
 MLH 01/20/2023
 GRH 10/26/2023
 CLUKE 11/04/25

COMMENT TABLE 3

TAGS L2
 TAGS L2
 TAGS L2