

Summary Lead Appr: ww 10/31 Clerk: _____ Lead Clerk: _____ Appr: GRH Print Date: 9/26/2025

Acct ID: 536121 MTL: 093W02B000300 Date: 10/21/25 Appr: GRH Prop Class: 451 RMV Prop Class: 451
 Situs: 9003 JACKSON HILL RD SE SALEM OR 97306 MaSaNh: 06 06 000 Unit: 44981 Year: 2025

Last Date Appraised: 09/10/2024 Appraiser: GERARDO RAMIREZ HERNANDEZ Tag: Y N Tag info:

Owner: CONNIE M LEMCO LT Last Sales Date: 07/23/2021 Roll Type: R
 Cycle Tag Sales Verification Other: _____ Inspection level: 1 2 3 4 LCB TTO INSP AV: 298420
 RMV Land: 284160 RMV Imp: 363890 RMV Total: 648050 MAV: 298420 MSAV: 0 SAV: 0
 Comment: 25-26: L3 9.10.24 WW

OSDs

Solar panels complete

Count	Code	Description	RMV	Code Area	Exception
1	MKTE	OSD - EXCELLENT	70000	92590	0

Land

Site: 1 Code Area: 92590 Size: 1.28 Acres Use Code: 005 Zone: REST SAV Use: Exception: 0
 Class: 2HD Value Source: Rural Restrictive Description: TWO HILL DRY RMV: 214160 Exception: Y N
 Adjustment(s): GSOIL Fire Patrol: Description:
 Comments: 00-01; REAPPRAISAL

Improvements - Residence / Manufactured Structures

Bldg: 1 Code Area: 92590 Stat Class: 142 Year Blt: 1949 Eff Year Blt: 1960 Sq.Ft: 2494 % Complete: 100.00
 Desc: Multi Story above grade Dimensions: RMV: 361040
 Func Obsc: 100 Econ %: 100 Other %: 100 Exception: 0 Adjust: Adjust RMV: 0

Floors

Type	Class	Display Group	Floor Size	Beds	Baths	Yr Blt	Eff Yr Blt	Inventory	Exception
First Floor	4	Finished	1768	1	FB-2	1949	1960	KIT-, ROOF, HVAC, BATH - 2	Y N
Attic	4	Finished	726	2	0	1949	1949	HVAC	Y N
Garage Detached	4	Unfinished	576	0	0	1949	1960	ROOF	Y N
Carport Attached	4	Unfinished	288	0	0	1949	1960	ROOF	Y N

Accessories

Description	Class	Size SqFt	Eff Yr Blt	RMV	Quantity	Exception
ASPHALT DRIVEWAY	4	2224	1980	5204	1	Y N
YARD IMPROVEMENTS GOOD	4	0	1960	29960	1	Y N

Improvements - Accessory Buildings

Bldg: 2 Code Area: 92590 Stat Class: 341 Year Blt: 2000 Eff Year Blt: 2000 Sq.Ft: 253 % Complete: 100.00
 Desc: Multi Purpose Shed (MP) Dimensions: 23x11 RMV: 2850
 Func Obsc: 100 Econ %: 100 Other %: 100 Exception: 0 Adjust: Adjust RMV: 0

Floors

Type	Class	Display Group	Floor Size	Beds	Baths	Yr Blt	Eff Yr Blt	Inventory	Exception
Multi-Purpose Bldg	4	Finished	253	0	0	2000	2000	FAIR	Y N

Accessories

Description	Class	Size SqFt	Eff Yr Blt	RMV	Quantity
No accessory data available					

Permits

Permit Number	Permit ID	Origin	Category	Type	Estimate Value	% Complete	Roll Type	Description
25-004109	83513	MARION COUNTY	TAGS/PERMITS	ALT ENERGY SYSTEM	18963	0	R	SOLAR ARRAY 15.2kW ON RES ROOF @ \$18,963

ACCOUNT # 536121

DATE: 10/21/25

RMV CLASS 451

PROP CLASS 451

MTL _____

APPR GPH

TAG Y (N)

COMMENTS: _____

RESIDENCE / MANUFACTURED STRUCTURES

ACCESSORY IMPROVEMENTS / OUTBUILDINGS

STAT _____ QLTY + - FLOOR _____
 AREA _____ EFF AREA _____ BED _____
 ROOF + HVAC +
 BATH PKG: _____ BATH _____ BATH + _____ 1/2 BTH
 FIREPLACE: _____
 KITCHEN - +
 YR BLT _____ EFF YR _____ ECON _____
 % COMP _____ % GOOD _____ FUNC _____
 EXCEPT Y N LUMP SUM: _____

MISC: _____
 YI CLASS _____ F G A E
 SKIRT + LIN FT _____
 COMMENT: _____

STAT _____ QLTY + - FLOOR _____
 AREA _____ EFF AREA _____ BED _____
 ROOF + HVAC +
 BATH PKG: _____ BATH _____ BATH + _____ 1/2 BTH
 FIREPLACE: _____
 KITCHEN - +
 YR BLT _____ EFF YR _____ ECON _____
 % COMP _____ % GOOD _____ FUNC _____
 EXCEPT Y N LUMP SUM: _____

MISC: _____
 YI CLASS _____ F G A E
 SKIRT + LIN FT _____
 COMMENT: _____

STAT _____ QLTY + - FLOOR _____
 AREA _____ EFF AREA _____ BED _____
 ROOF + HVAC +
 BATH PKG: _____ BATH _____ BATH + _____ 1/2 BTH
 FIREPLACE: _____
 KITCHEN - +
 YR BLT _____ EFF YR _____ ECON _____
 % COMP _____ % GOOD _____ FUNC _____
 EXCEPT Y N LUMP SUM: _____

MISC: _____
 YI CLASS _____ F G A E
 SKIRT + LIN FT _____
 COMMENT: _____

TYPE Solar
 STAT / CLASS 905
 SIZE _____
 FAIR 20K
 AVERAGE
 GOOD
 EXCELLENT

BATH _____
 YR BLT 2025
 EFF YR 2025
 % COMP 100
 EXCEPT Y (N)
 MISC: _____

COMMENT: _____

TYPE _____
 STAT / CLASS _____
 SIZE _____
 FAIR
 AVERAGE
 GOOD
 EXCELLENT

BATH _____
 YR BLT _____
 EFF YR _____
 % COMP _____
 EXCEPT Y N
 MISC: _____

COMMENT: _____

TYPE _____
 STAT / CLASS _____
 SIZE _____
 FAIR
 AVERAGE
 GOOD
 EXCELLENT

BATH _____
 YR BLT _____
 EFF YR _____
 % COMP _____
 EXCEPT Y N
 MISC: _____

COMMENT: _____

TYPE _____
 STAT / CLASS _____
 SIZE _____
 FAIR
 AVERAGE
 GOOD
 EXCELLENT

BATH _____
 YR BLT _____
 EFF YR _____
 % COMP _____
 EXCEPT Y N
 MISC: _____

COMMENT: _____



SKETCH/AREA TABLE ADDENDUM

SUBJECT INFO

File No.: 536121 Parcel No.: 093W02B 00300
 Property Address: 9003 JACKSON HILL RD SE
 City: SALEM County: MARION State: OR ZipCode: 97306
 Owner:
 Client: Client Address:
 Appraiser Name: Inspection Date:

SKETCH

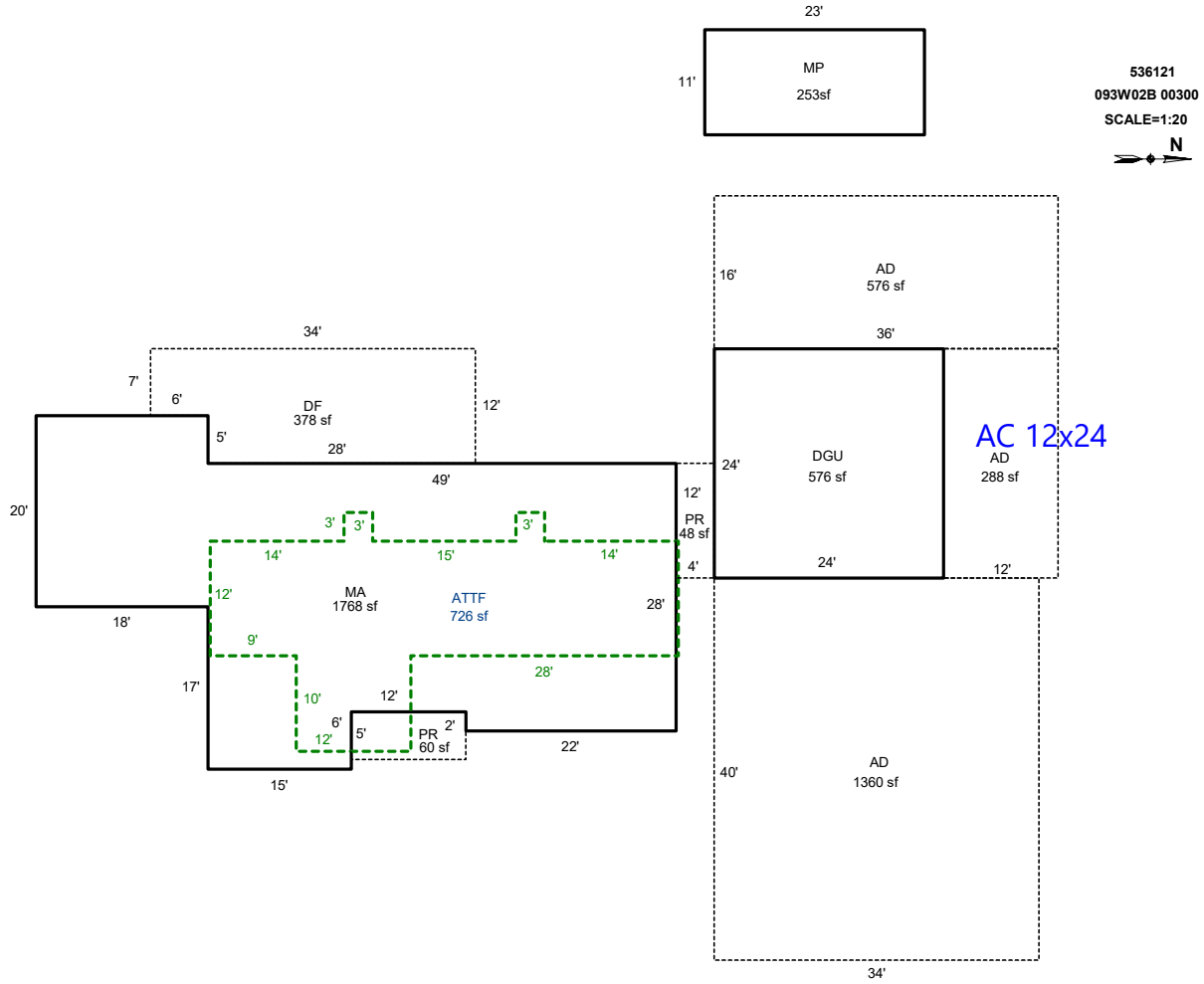

AREA CALCULATIONS SUMMARY

Code	Description	Factor	Net Size	Perimeter	Net Totals
GBA3	MP	1	253	68	253
GLA1	MA	1	1768	212	1768
GLA2	ATTF	1	726	154	726
GAR	DGU	1	576	96	576
P/P	PR	1	48	32	
	AD	1	1360	148	
	AD	1	576	104	
	AD	1	288	72	
	PR	1	60	34	
	DF	1	378	92	2710
	Net LIVABLE	cnt	2 (rounded)		2,494
	Net BUILDING	cnt	1 (rounded)		253

COMMENT TABLE 1

DRAWN BY JRONDEMA 6/25/18
 UPD BY WW 9.19.24

COMMENT TABLE 2

WW 9.10.24
GR4 10/21/25

COMMENT TABLE 3

CYCLE L3
TAGS L2