

SKETCH/AREA TABLE ADDENDUM

SUBJECT INFO

File No.: 329661 Parcel No.: 072W06AC12500
 Property Address: 4360 RACCOON AV NE
 City: SALEM County: State: OR ZipCode: 97305
 Owner:
 Client: Client Address:
 Appraiser Name: Inspection Date:

SKETCH

329661
072W06AC12500

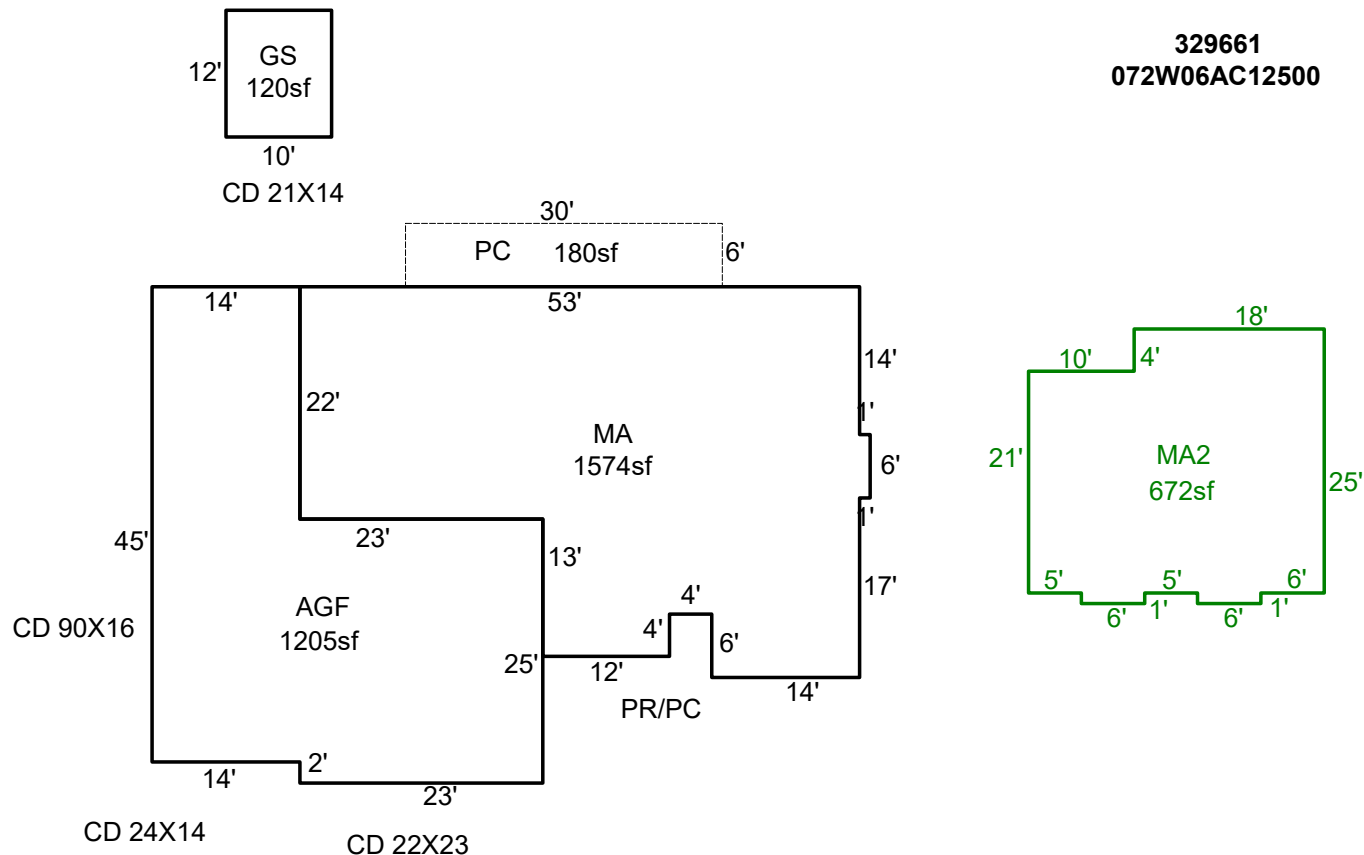

Sketch by ApexSketch

AREA CALCULATIONS SUMMARY

Code	Description	Factor	Net Size	Perimeter	Net Totals
GBA	GS	1.0	120.0	44.0	120.0
GLA1	MA	1.0	1574.0	190.0	1574.0
GLA2	MA2	1.0	672.0	110.0	672.0
GAR	AGF	1.0	1205.0	168.0	1205.0
P/P	PC	1.0	180.0	72.0	180.0

COMMENT TABLE 1

DRAWN BY TB 09/17/09
 UPDATED BY LK 12.2.25

COMMENT TABLE 2

11.18.25 CYCLE GM

COMMENT TABLE 3

Net LIVABLE cnt 1 (rounded) 2,246
 Net BUILDING cnt 1 (rounded) 120