

SKETCH/AREA TABLE ADDENDUM

SUBJECT INFO

File No.: 611562 Parcel No.: 083W11BA10200
 Property Address: 1720 Strong Rd SE
 City: Salem County: Marion State: OR ZipCode: 97302
 Owner:
 Client: Client Address:
 Appraiser Name: Inspection Date:

SKETCH

611562
083W11BA10200

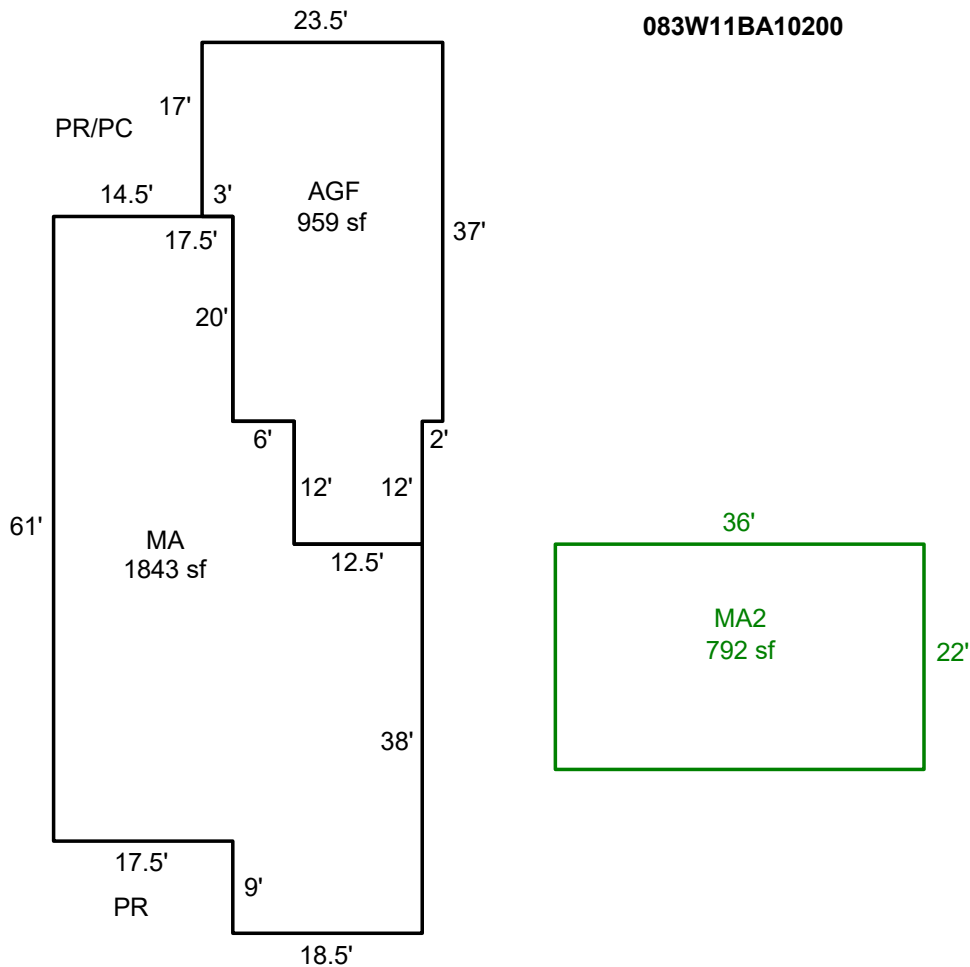

Sketch by ApexSketch

AREA CALCULATIONS SUMMARY						COMMENT TABLE 1		
Code	Description	Factor	Net Size	Perimeter	Net Totals			
GLA	MA	1.0	1842.5	212.0	1842.5	Drawn by AE 12.12.25		
GLA2	MA2	1.0	792.0	116.0	792.0			
GAR	AGF	1.0	959.5	145.0	959.5			
Net LIVABLE						cnt	2 (rounded)	2,635
						COMMENT TABLE 2	COMMENT TABLE 3	