

Summary

Lead Appr: WW 12/3

Clerk: _____

Lead Clerk: _____

Appr: MDL Juyat

Print Date:

12/2/2025

Acct ID: 535533

MTL: 092W24C000900

Date: 11/20/25

Appr: MDL

Prop Class: 559

RMV Prop Class: 509

Situs: 12803 BRICK RD SE TURNER OR 97392

MaSaNh: 07 06 000

Unit: 45849

Year: 2026

Last Date Appraised: 12/12/2024

Appraiser: MATT LORD

Tag: Y N

Tag info: 2026 - Tags/Permit (Completion)

Owner: KLINE FAM RLT

Last Sales Date: 02/27/2009

Roll Type: R

Cycle Tag Sales Verification Other: _____

Inspection level: 1 2 3 4 LCB TTO INSP

AV: 187417

RMV Land: 670410

RMV Imp: 214390

RMV Total: 884800

MAV: 117350

MSAV: 70067

SAV: 156472

Comment: 25-26: L2 MDL 12/12/24 TAG
MS tag, 100% #CL#10, pull tag 9-28-21//

Notations 26-27: LTH 100%

RP/MS	Code	Description
MS	ZONED	FARM EFU ZONED
MS	ZONED	FARM EFU ZONED
MS	ZONED	FARM EFU ZONED
RP	ZONED	FARM EFU ZONED

OSDs

Count	Code	Description	RMV	Code Area	Exception
2	SAF	SA OSD - FAIR	45000	05545	0

Land

Site: 3 Code Area: 05545 Size: 1.00 Acres Use Code: 005 Zone: REST SAV Use: 011 Exception: 0
 Class: 4BISS Value Source: Farm Homesite Description: FOUR BENCH IRR SPECIAL SOUTH RMV: 16990 Exception: Y N
 Adjustment(s): GSOIL, IRR Fire Patrol: Description:
 Comments: Liability year - 2009

25-26: Updated land class

Site: 4 Code Area: 05545 Size: 26.68 Acres Use Code: 005 Zone: REST SAV Use: 011 Exception: 0
 Class: 2BISS Value Source: Farm Use - EFU Description: TWO BENCH IRR SOUTH SPECIAL RMV: 521190 Exception: Y N
 Adjustment(s): GSOIL, IRR Fire Patrol: Description:
 Comments: Liability year - 1980 / 550040

Site: 5 Code Area: 05545 Size: 1.00 Acres Use Code: 005 Zone: REST SAV Use: 011 Exception: 0
 Class: 2BISS Value Source: Farm Homesite Description: TWO BENCH IRR SOUTH SPECIAL RMV: 18690 Exception: Y N
 Adjustment(s): GSOIL, IRR Fire Patrol: Description:
 Comments: Liability year - 2009 / 550040

Site: 6 Code Area: 05545 Size: 1.32 Acres Use Code: 005 Zone: REST SAV Use: 011 Exception: 0
 Class: 4BISS Value Source: Farm Use - EFU Description: FOUR BENCH IRR SPECIAL SOUTH RMV: 23540 Exception: Y N
 Adjustment(s): GSOIL, IRR Fire Patrol: Description:
 Comments: Liability year - 1980 / 550040

Improvements - Residence / Manufactured Structures

Bldg: 3 Code Area: 05545 Stat Class: 128 Year Blt: 1989 Eff Year Blt: 1977 Sq.Ft: 0 % Complete: 100.00
 Desc: Res other improvements Dimensions: RMV: 22790
 Func Obsc: 100 Econ %: 100 Other %: 100 Exception: 0 Adjust: Adjust RMV: 0

Floors

Type	Class	Display Group	Floor Size	Beds	Baths	Yr Blt	Eff Yr Blt	Inventory	Exception
Garage Attached	2	Unfinished	384	0	0	1989	1977	ROOF	Y N

Accessories

Description	Class	Size SqFt	Eff Yr Blt	RMV	Quantity
YARD IMPROVEMENTS FAIR	3	1	1977	6878	1

Bldg: 5 Code Area: 05545 Stat Class: 457 + Year Blt: 1985 Eff Year Blt: 1985 Sq.Ft: 1296 % Complete: 100.00
 Desc: MANUF STRUCT, CLASS 5, 26' THROUGH 28' WIDE DOUBLE Dimensions: 48x27, RMV: 41200
 Func Obsc: 100 Econ %: 100 Other %: 100 Exception: 0 Adjust: Adjust RMV: 0 Subtype: R

Floors

Type	Class	Display Group	Floor Size	Beds	Baths	Yr Blt	Eff Yr Blt	Inventory	Exception
First Floor	5 +	Finished	1296	3	FB-2	1985	1985	SKRT+, ROOF+, HVAC+, KIT-	Y N

Accessories

Description	Class	Size SqFt	Eff Yr Blt	RMV	Quantity
No accessory data available					

Improvements - Accessory Buildings

Bldg: 1 Code Area: 05545 Stat Class: 341 Year Blt: 1971 Eff Year Blt: 1971 Sq.Ft: 240 % Complete: 100.00

Desc: Multi Purpose Shed (MP)

Dimensions: 20x12 RMV: 1200

Func Obsc: 100

Econ %: 100

Other %: 100

Exception: 0

Adjust:

Adjust RMV: 0

Floors

Type Class Display Group Floor Size Beds Baths Yr Blt Eff Yr Blt Inventory

Multi-Purpose Bldg 4 Finished 240 0 0 1971 1971 FAIR Exception: Y N

Accessories

Description Class Size SqFt Eff Yr Blt RMV Quantity

No accessory data available

Bldg: 2 Code Area: 05545 Stat Class: 341 Year Blt: 1971 Eff Year Blt: 1971 Sq.Ft: 240 % Complete: 100.00

Desc: Multi Purpose Shed (MP)

Dimensions: 20x12 RMV: 1200

Func Obsc: 100

Econ %: 100

Other %: 100

Exception: 0

Adjust:

Adjust RMV: 0

Floors

Type Class Display Group Floor Size Beds Baths Yr Blt Eff Yr Blt Inventory

Multi-Purpose Bldg 4 Finished 240 0 0 1971 1971 FAIR Exception: Y N

Accessories

Description Class Size SqFt Eff Yr Blt RMV Quantity

No accessory data available

Bldg: 4 Code Area: 05545 Stat Class: 351 Year Blt: 2009 Eff Year Blt: 2009 Sq.Ft: 2400 % Complete: 100.00

Desc: General Purpose Building (GB)

Dimensions: 40x60 RMV: 143800

Func Obsc: 100

Econ %: 100

Other %: 100

Exception: 0

Adjust:

Adjust RMV: 0

Floors

Type Class Display Group Floor Size Beds Baths Yr Blt Eff Yr Blt Inventory

General Purpose Bldg 6 Finished 2400 0 0 2009 2009 AVG Exception: Y N

GP Building Attic 6 Finished 2400 0 0 2009 2009 BATH - 1 Exception: Y N

Accessories

Description Class Size SqFt Eff Yr Blt RMV Quantity

No accessory data available

Bldg: 8 Code Area: 05545 Stat Class: 355 Year Blt: 2024 Eff Year Blt: 2024 Sq.Ft: 680 % Complete: 85.00

Desc: Lean-to Heavy (LTH)

Dimensions: 20x34 RMV: 4200

Func Obsc: 100

Econ %: 100

Other %: 100

Exception: 0

Adjust:

Adjust RMV: 0

100

Floors

Type Class Display Group Floor Size Beds Baths Yr Blt Eff Yr Blt Inventory

Lean-to Heavy Duty 6 Finished 680 0 0 2024 2024 Exception: Y N

Accessories

Description Class Size SqFt Eff Yr Blt RMV Quantity

No accessory data available

Farm Notes

2025FARM

2/5/25: Inspected by CWO L4 during tags, farm use ok - grass seed

SKETCH/AREA TABLE ADDENDUM

SUBJECT INFO

File No.: 535533 Parcel No.: 092W24C 00900
 Property Address: 12793-12803 BRICK RD SE
 City: Salem County: Marion State: OR ZipCode: 97392
 Owner:
 Client: Client Address:
 Appraiser Name: Inspection Date:

SKETCH

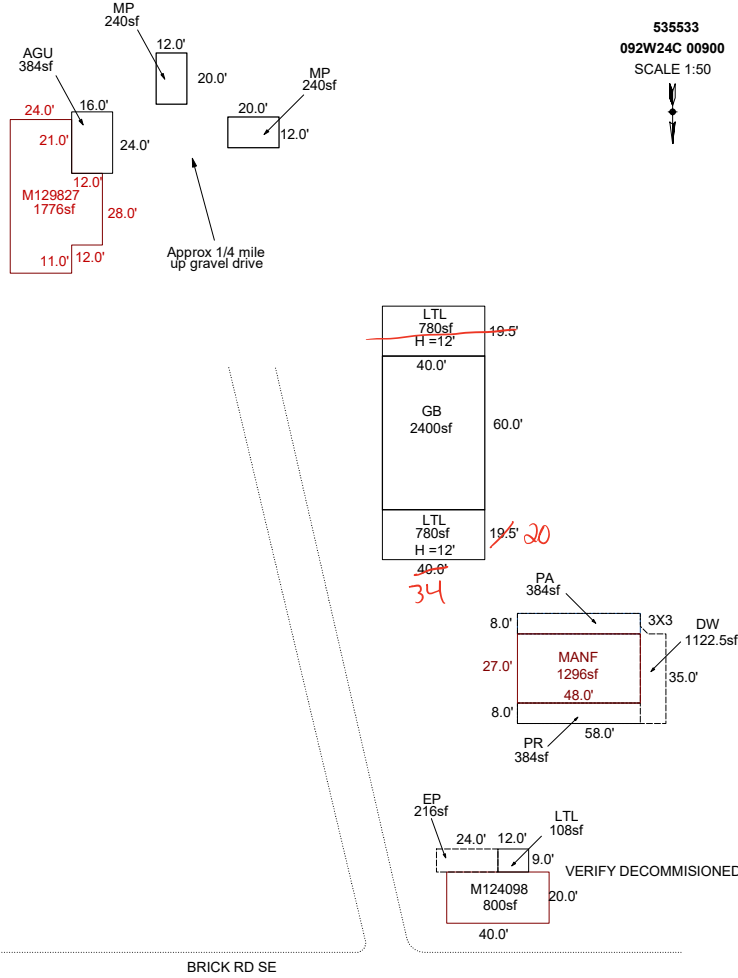

Sketch by ApexSketch

AREA CALCULATIONS SUMMARY

Code	Description	Factor	Net Size	Perimeter	Net Totals
GBA1	GB	1.0	2400.0	200.0	
	MP	1.0	240.0	64.0	
	MP	1.0	240.0	64.0	
	LTL	1.0	780.0	119.0	
	LTL	1.0	780.0	119.0	4440.0
GLA	MANF	1.0	1296.0	150.0	1296.0
GAR	AGU	1.0	384.0	80.0	384.0
OTH	M129827	1.0	1776.0	192.0	
	M124098	1.0	800.0	120.0	2576.0
P/P	EP	1.0	216.0	66.0	
	PA	1.0	384.0	112.0	
	DW	1.0	1122.5	296.2	
	PR	1.0	384.0	112.0	2106.5
	Net LIVABLE	cnt	1 (rounded)		1,296
	Net BUILDING	cnt	5 (rounded)		4,440

COMMENT TABLE 1

APEX BY CJURAN 04/26/2021 555-20-008345
 UPDATED BY CLOBERG 09/13/24 24-005334 LTL GB

COMMENT TABLE 2

COMMENT TABLE 3

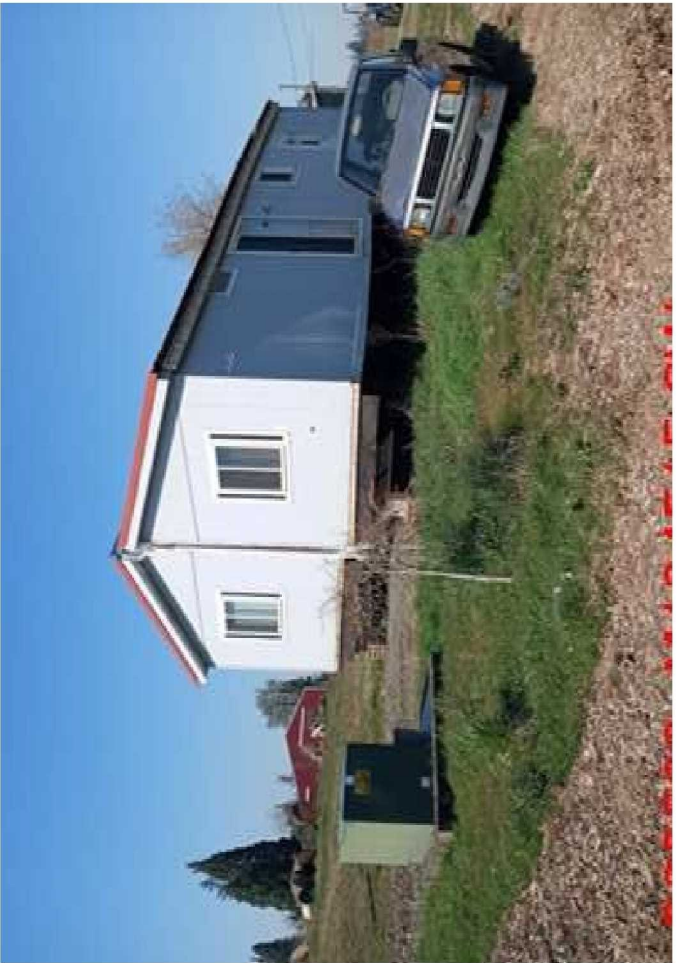



**535533 Manuf MA Front E Side
2021-09-28 L2**



**535533 Manuf 124098
2021-09-28 L2**



**535533 40x60 DGOF-DG2F
2021-09-28 L2**



092W24C 00900

R35533

551 01D A99E

00550040

00550040

GLIDEWELL FARMS INC

30 Acres

1/30/02

BUILDING DIAGRAM AND OUTBUILDINGS

ACCT. NO. 61818-000

MAP NO. 24-9-2W

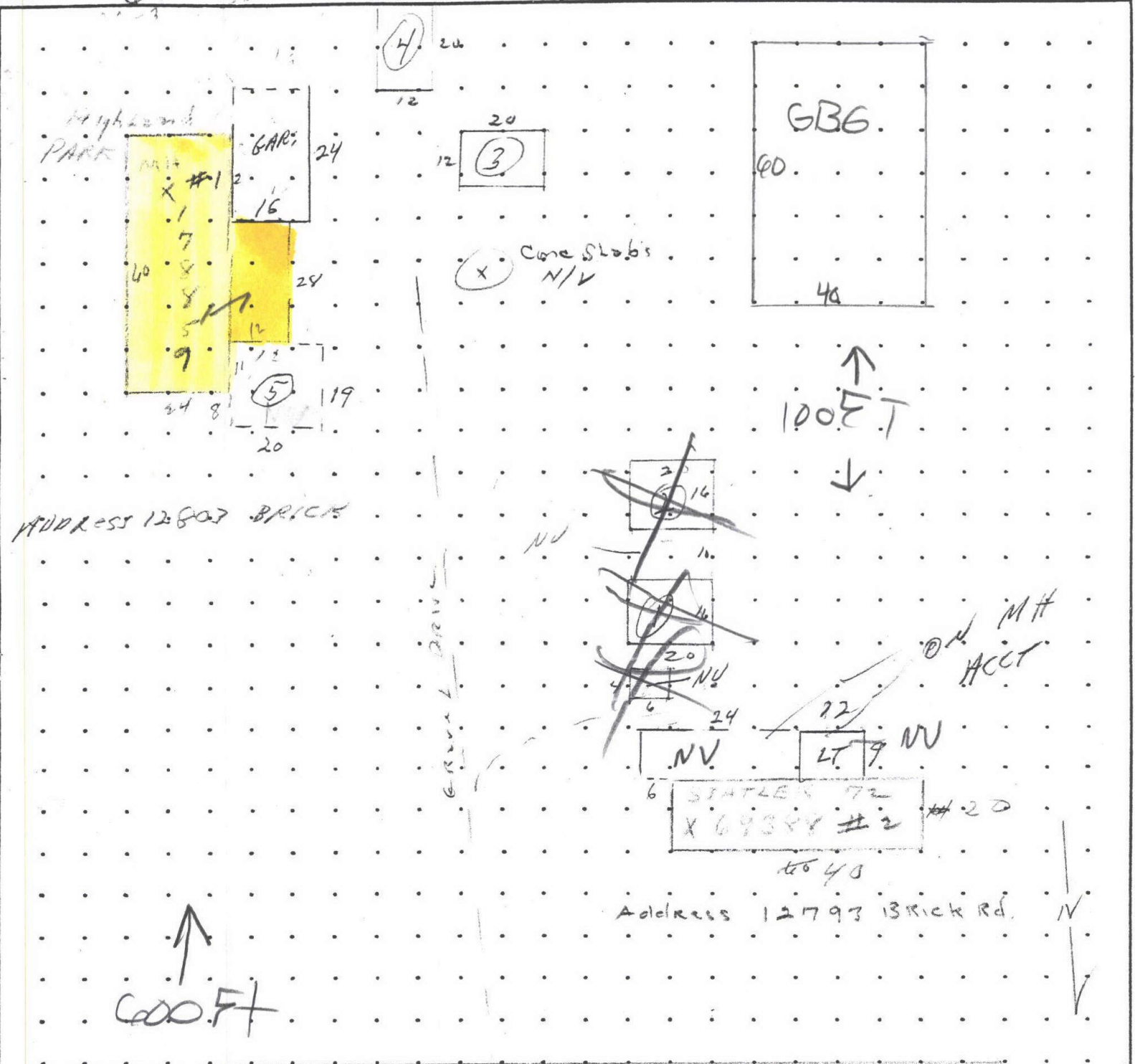

MEASUREMENT VERIFIED	
DATE	BY
1-9-84	53 JC
10-23-91	Ref #83
6-13-02	82

REMARKS: Two M H S In Both FARM Related

R 35533 BUILDING DIAGRAM AND OUTBUILDINGS

ACCT. NO. 61818-000

MAP NO. 24-9-2W

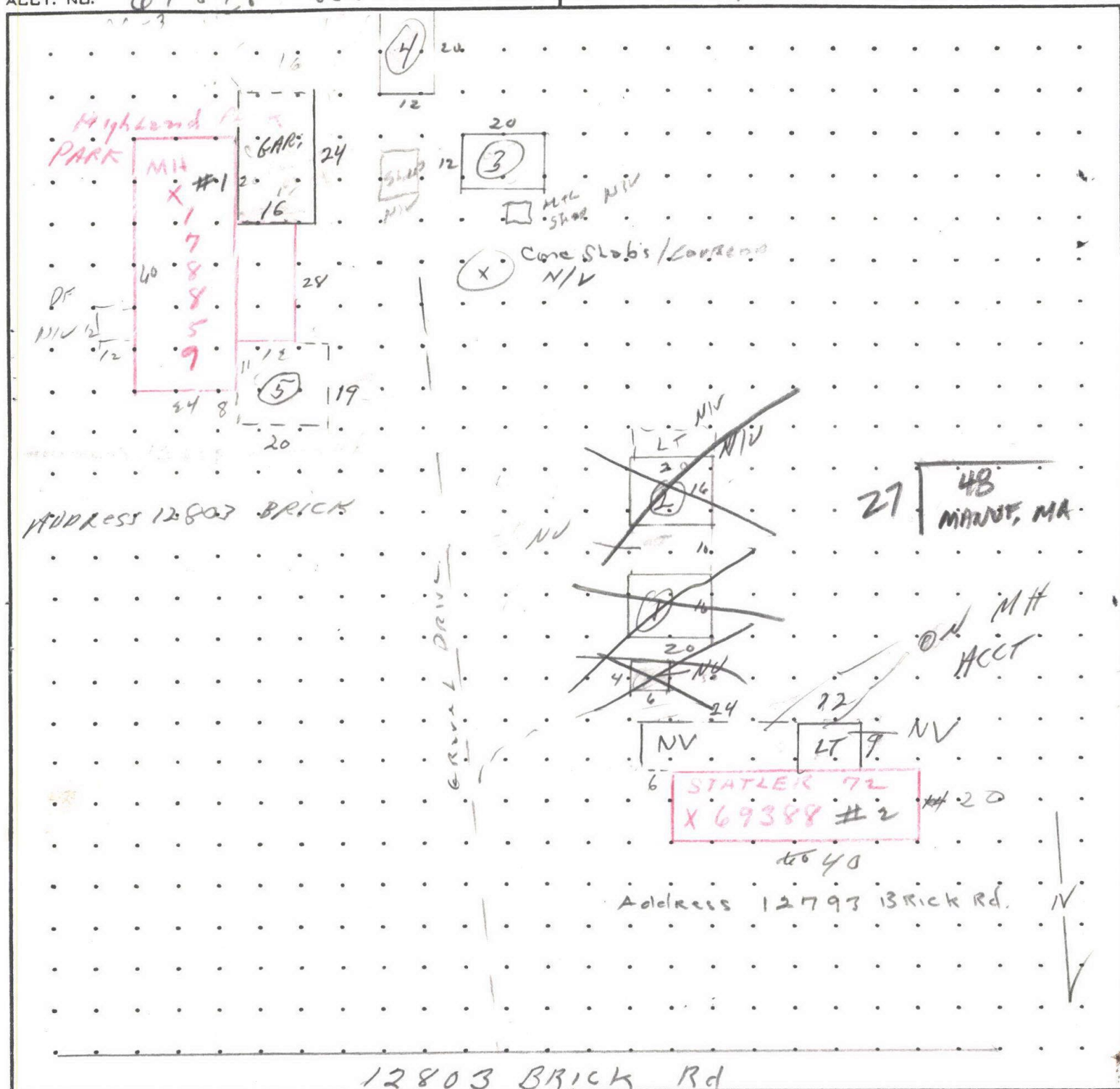

12803 BRICK Rd

MEASUREMENT VERIFIED

REMARKS:

Two M/H sites Both FARM Related.

DATE

BY

1-9-84

SS JC

10-23-91

Ref #83

SKETCH/AREA TABLE ADDENDUM

SUBJECT INFO

File No.: R35533 Parcel No.: 092W24C 00900
 Property Address: 12793-12803 BRICK RD SE
 City: TURNER County: State: OR ZipCode: 97392
 Owner: Client: Client Address:
 Appraiser Name: Inspection Date:

SKETCH

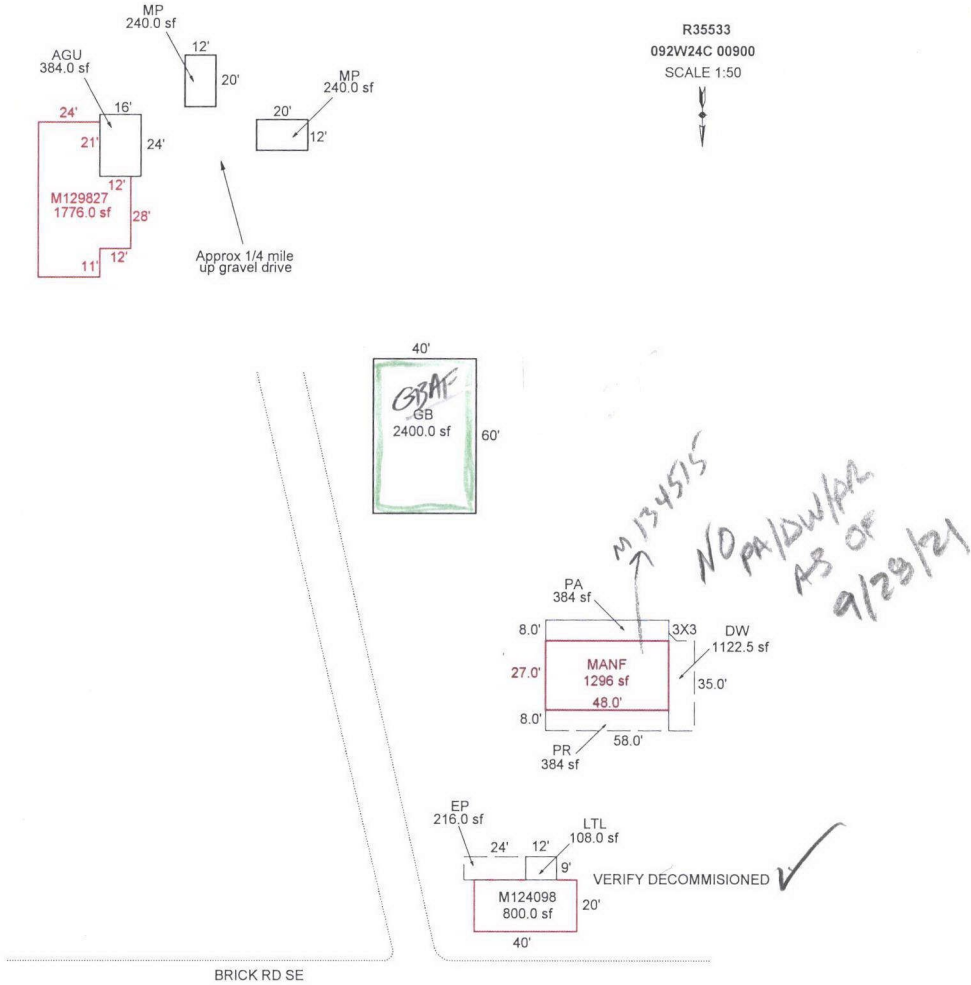

Sketch by Apex Sketch

AREA CALCULATIONS SUMMARY

COMMENT TABLE 1

Code	Description	Factor	Net Size	Perimeter	Net Totals
GBA1	GB	1.0	2400.0	200.0	
	MP	1.0	240.0	64.0	
	MP	1.0	240.0	64.0	2880.0
GLA	MANF	1.0	1296.0	150.0	1296.0
GAR	AGU	1.0	384.0	80.0	384.0
OTH	M129827	1.0	1776.0	192.0	
	M124098	1.0	800.0	120.0	2576.0
P/P	EP	1.0	216.0	66.0	
	PA	1.0	384.0	112.0	
	DW	1.0	1122.5	296.2	
	PR	1.0	384.0	112.0	2106.5
	Net LIVABLE	cnt	1 (rounded)		1,296
	Net BUILDING	cnt	3 (rounded)		2,880

APEX BY CJURAN 04/26/2021 555-20-008345

COMMENT TABLE 2

COMMENT TABLE 3

SKETCH/AREA TABLE ADDENDUM

Parcel No 092W24C 00900

File No R35533

Property Address 12793-12803 BRICK RD SE

City TURNER

State OR

Zip 97392

Owner

Client

Appraiser Name

SUBJECT

IMPROVEMENTS SKETCH

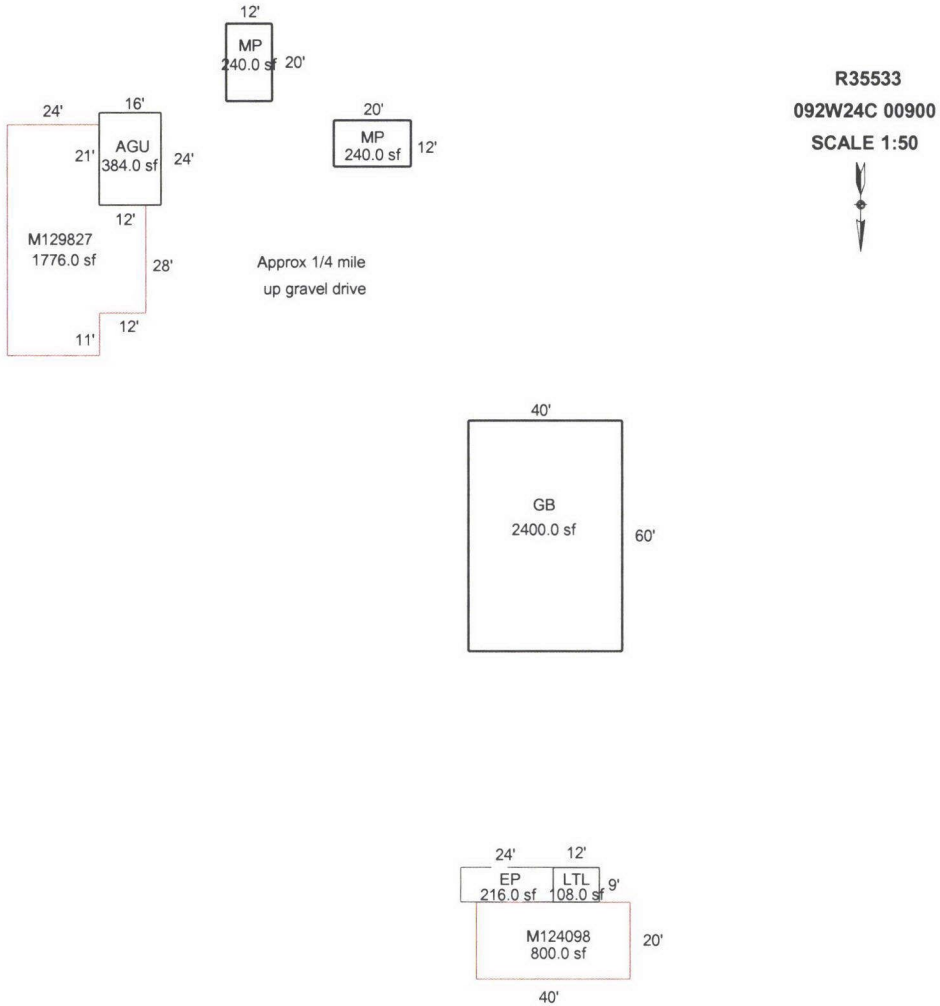

Scale: 1 = 50

AREA CALCULATIONS

AREA CALCULATIONS SUMMARY

Code	Description	Factor	Net Size	Perimeter	Net Totals
GBA1	GB	1.00	2400.0	200.0	
	MP	1.00	240.0	64.0	
	MP	1.00	240.0	64.0	2880.0
GAR	AGU	1.00	384.0	80.0	384.0
P/P	EP	1.00	216.0	66.0	216.0
OTH	M129827	1.00	1776.0	192.0	
	M124098	1.00	800.0	120.0	2576.0
Net BUILDING Area (rounded w/ factors)					2880

Comment Table 1

APEX BY CE 12/30/09
Akpex updated 12/10/10 to delete MP (320sf) Jane

Comment Table 2

Comment Table 3

R35533 092W24C 00900

Prop Class: 559 Prop Code: A99E Fran: 10

Appr #: 10 Date: 9-28-2021

Situs Address

TTO LCB Insp: 1 2 3 4 Cycle Tags Farm Forest

Owner KLINE,SHIRLEY L &

Pictom Sales Verif Other: _____

RMV Land: 437,660

RMV Imps: 106,370

RMV Total: 544,030

M50 Total: 153,980

For: 2022-2023

Notes: Please name NOTED CHANGES, ADDED M/6 12/098 MANUF.
pm TAG

Seg: 3.1 AGU ATTACHED GARAGE

Method: R05 Roof Cover: COMP Int Comp: Adj: RLCM2

Class: 2 Roof Style:

Area: 384 Eff 384 Flooring: DIRT

Dimens: 24 x 16 Plumbing: Electrical: Qty: _____

Found: Heat/AC: Bedrooms: % Comp: _____

Ex Wall: Fireplace: Year: 1989 Eff: 1977 Adj: _____

AddFactor1: AddFactor2: AddFactor3: RMV: 15,280

Exc Code: _____ Comment/Adj: _____ L/S: _____

Accessory Improvements

Seg: 3.2 YI3F ATTACHED GARAGE

Method: R05 Roof Cover: Int Comp: Adj:

Class: Roof Style:

Area: 1 Eff: 1 Flooring: Electrical: % Comp: _____

Dimens: x Plumbing: Bedrooms: Adj: _____

Found: Heat/AC: Year: Eff: RMV: 5,250

Ex Wall: Fireplace: AddFactor3:

AddFactor1: AddFactor2:

Exc Code: _____ Comment/Adj: _____ L/S: _____

Out Buildings

Seg: 1.1 MP MULTI/MISC PURPOSE BUILDING

Method: F09 Roof Cover: METAL Int Comp: Adj: FLCMCP

Class: 4 Roof Style:

Area: 240 Eff: 240 Flooring: CONC

Dimens: 20 x 12 Plumbing: Electrical: % Comp: _____

Found: CONC Heat/AC: Bedrooms: Func: _____

Ex. Wall PLYWD;8FT Fireplace: Year: Eff: 1971 Value: 870

AddFactor1: AddFactor2: AddFactor3:

Exc Code: _____ Comment/Adj: _____ L/S: _____

Seg: 2.1 MP MULTI/MISC PURPOSE BUILDING

Method: F09 Roof Cover: METAL Int Comp: Adj: FLCMCP

Class: 4 Roof Style:

Area: 240 Eff: 240 Flooring: CONC

Dimens: 20 x 12 Plumbing: Electrical: % Comp: _____

Found: CONC Heat/AC: Bedrooms: Func: _____

Ex. Wall 8FT;PLYWD Fireplace: Year: Eff: 1971 Value: 870

AddFactor1: AddFactor2: AddFactor3:

Exc Code: _____ Comment/Adj: _____ L/S: _____

Seg: 4.1 GB GENERAL PURPOSE BLDG

Method: F09 Roof Cover: BKENAM Int Comp: Adj: FLCMMP

Class: 6 Roof Style: GABLE

Area: 2400 Eff: 2400 Flooring: CONC

Dimens: 40 x 60 Plumbing: Electrical: 220V % Comp: _____

Found: FRAME Heat/AC: Bedrooms: Func: _____

Ex. Wall 20FT Fireplace: Year: 2009 Eff: 2009 Value: 40,820

AddFactor1: AddFactor2: AddFactor3:

Exc Code: 1/0 Comment/Adj: _____ L/S: _____

Seg: 4.2 GBAU GENERAL PURPOSE BLDG

Method: F09 Roof Cover: Int Comp: Adj: FLCM

Class: 6 Roof Style:

Area: 2400 Eff: 2400 Flooring: Plumbing: BTH 1 Electrical: 110 % Comp: _____

Dimens: 40 x 60 Heat/AC: Bedrooms: Func: _____

Found: Fireplace: Year: 2009 Eff: 2009 Value: 43,280

Ex. Wall AddFactor2: AddFactor3:

AddFactor1: 1/0 Comment/Adj: FIRM kitchen L/S: _____

Notes: Tags Cycle Sales Verification Other:
GB, GBAU 100% complete. Delete MP(seg.1) - gone. Pull tag

RMV Land: 341,000	RMV Imp: 72,360	RMV Total: 413,360	M50 Total: 98,260		
Seg.Type AGU	Seg. # 4.1	Method: R05	Class 2	Area 384	Eff Area 384
Length 24	Width 16	Roof Cover COMP	Plumbing	Heat	
Fireplace	Inter. Comp:			Bedrooms	
Year Built 1989	Eff. Year Built 1977	Cond. P F A G E			
Adj Codes RLCM2	Qty ___	% Comp ___	Func ___	Econ ___	RMV: 8,690
Lump Sum ___	Except Code/Year ___	Comments ___			

Accessory Improvements

Seg.Type YI3F	Seg. # 4.2	Method: R05	Class	Area 1	Eff Area 1
Length	Width	Cond. P F A G E % Comp ___ Econ ___ RMV: 3,000			
Year Built	Eff. Year Built:	Comments ___			
Lump Sum ___	Except Code/Year ___	Comments ___			

Out Buildings

Seg.Type MP	Seg. # 1.1	Method: F09	Class 4	Area 320	Eff Area 320
Length 20	Width 16	Foundation CONC	Ex. Wall PLYWD;8FT	Roof Cover METAL	
Roof Style	Floor CONC		Plumbing	Heat	
Heat	Int. Comp.		Elect.	Yr. Blt.	Eff. Yr. Blt: 1966
Cond. P F A G E	Adj. Codes FLCM	% Comp ___	Func ___	Econ ___	RMV: 950
Lump Sum ___	Except Code/Year ___	Comments <u>gone</u>			

Seg.Type MP	Seg. # 2.1	Method: F09	Class 4	Area 240	Eff Area 240
Length 20	Width 12	Foundation CONC	Ex. Wall PLYWD;8FT	Roof Cover METAL	
Roof Style	Floor CONC		Plumbing	Heat	
Heat	Int. Comp.		Elect.	Yr. Blt.	Eff. Yr. Blt: 1971
Cond. P F A G E	Adj. Codes FLCM	% Comp ___	Func ___	Econ ___	RMV: 920
Lump Sum ___	Except Code/Year ___	Comments ___			

Seg.Type MP	Seg. # 3.1	Method: F09	Class 4	Area 240	Eff Area 240
Length 20	Width 12	Foundation CONC	Ex. Wall 8FT;PLYWD	Roof Cover METAL	
Roof Style	Floor CONC		Plumbing	Heat	
Heat	Int. Comp.		Elect.	Yr. Blt.	Eff. Yr. Blt: 1971
Cond. P F A G E	Adj. Codes FLCM	% Comp ___	Func ___	Econ ___	RMV: 920
Lump Sum ___	Except Code/Year ___	Comments ___			

Seg.Type GB	Seg. # 5.1	Method: F09	Class 6	Area 2400	Eff Area 2400
Length 40	Width 60	Foundation FRAME	Ex. Wall 20FT	Roof Cover BKENAM	
Roof Style GABLE	Floor DIRT		Plumbing	Heat	
Heat	Int. Comp. <u>CONC</u>		Elect. <u>220V</u>	Yr. Blt. 2009	Eff. Yr. Blt: 2009
Cond. P F <u>A</u> G E	Adj. Codes FLCM;COMPL	% Comp <u>100</u>	Func ___	Econ ___	RMV: 23,550
Lump Sum ___	Except Code/Year <u>M/M</u>	Comments ___			

Seg.Type GBAU	Seg. # 5.2	Method: F09	Class 6	Area 2400	Eff Area 2400
Length 40	Width 60	Foundation	Ex. Wall	Roof Cover	
Roof Style	Floor		Plumbing	Heat	
Heat	Int. Comp.		Elect.	Yr. Blt. 2009	Eff. Yr. Blt: 2009
Cond. P F <u>A</u> G E	Adj. Codes FLCM;COMPL	% Comp <u>100</u>	Func ___	Econ ___	RMV: 34,330
Lump Sum ___	Except Code/Year <u>M/M</u>	Comments ___			

- - Improvement Maintenance BEFORE EXCEPTION - -

Property ID: R35533 092W24C 00900 Imp 4 Of 4 * Changed *
 Owners Name: KLINE FAM TR & Nbhd:EN.RUR
 Living Area/Value : 0 / \$0

- | | | | |
|-----------------|-------------------------------|-----------------|----------------|
| 1. Type Imp | : F | 7. Appr Method | : C Cost Value |
| 2. Description | : GENERAL PURPOSE BLDG | 8. Cost Value | : \$57,880 |
| 3. Bldg Type | : | 9. Income Value | : \$0 |
| 4. Cmplx/Bldg | : | 10. Trend Adj% | : |
| 5. M/S Zip Code | : | RMV Imprv | : \$57,880 |
| 6. Comment | : 10-11: PER #36 ADD GB @ 80% | | |

- - Improvement Segments - -

Seg ID	Type - Description.....	Class	Area	Mthd	RMV Total
S1	GB - GENERAL PURPOSE BUIL	6	2400	F09	\$23,550
S2	GBAU - GENERAL PURPOSE BU	6	2400	F09	\$34,330
Totals:			0		\$57,880

T-Trend	CM-Comment	S*-Add Seg	(.) More
---------	------------	------------	----------







12/18/09

R35533

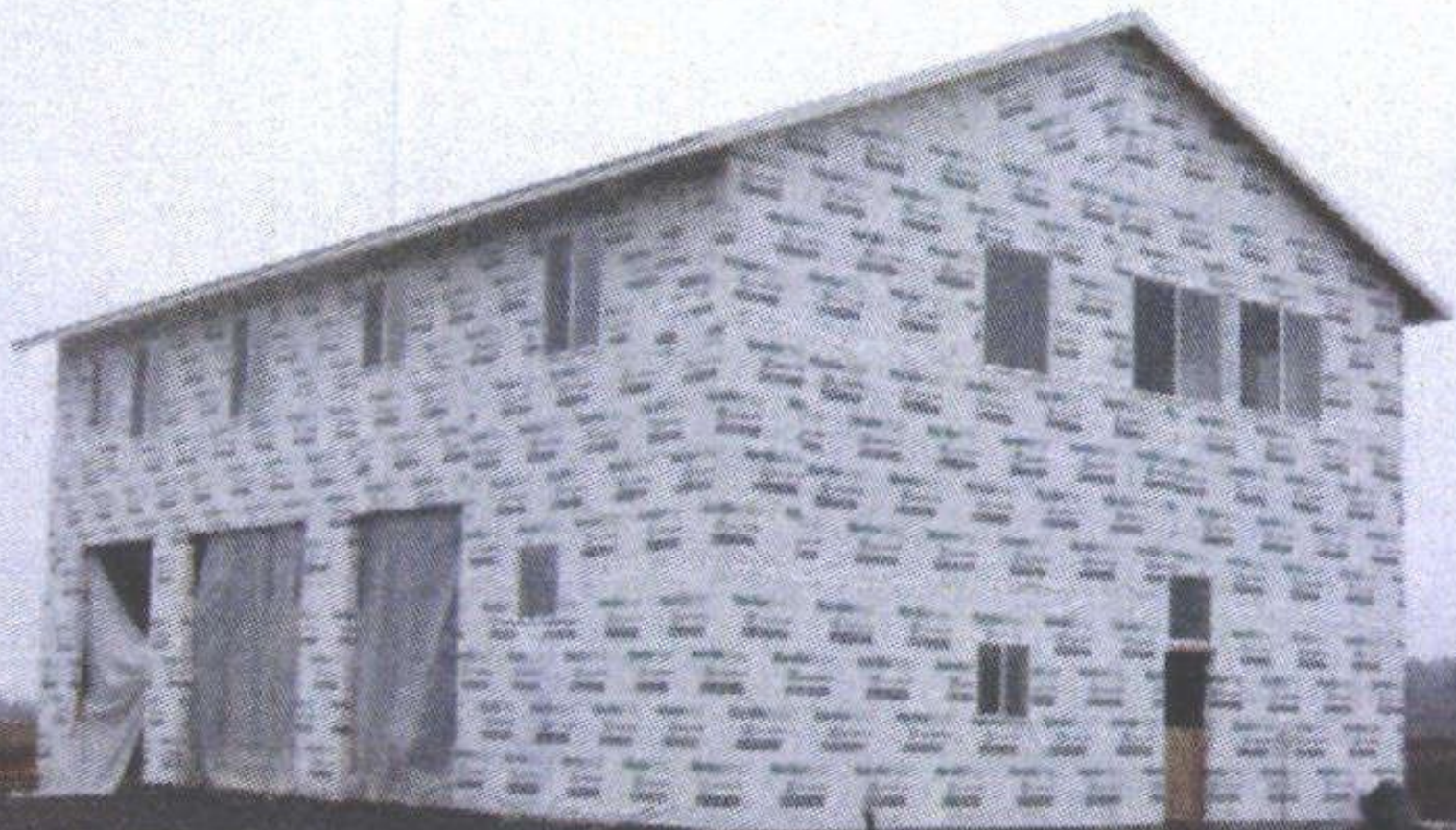

12/1/10

R 355 33



TOTAL



M129827

12/18/09

Acct ID: 535533 MTL: 092W24C000900 Date: **12/12/24** Appr: **MDL** Prop Class: 559 RMV Prop Class: 559
 Situs: 12803 BRICK RD SE TURNER OR 97392 MaSaNh: 07 06 000 Unit: 45849 Year: **2024**
 Last Date Appraised: 09/28/2021 Appraiser: MATT LORD Retag: **N** Tag info: 2025 - NEW CONSTRUCTION (Outbuilding)
 Owner: KLINE FAM RLK Roll Type: R
 Cycle: **Tag** Sales Verification Other: _____ Inspection level: 1 **2** 3 4 LCB TTO INSP AV: 177681
 RMV Land: 474270 RMV Imp: 197470 RMV Total: 671740 MAV: 110630 MSAV: 67051 SAV: 153740
 Comment: MS tag, 100% #CL#10, pull tag 9-28-21// **24-005334 ADD TWO LTH to shop**

Notations **LTH's**
25-26" 85% complete

RP/MS	Code	Description
MS	ZONED	FARM EFU ZONED
MS	ZONED	FARM EFU ZONED
MS	ZONED	FARM EFU ZONED
RP	ZONED	FARM EFU ZONED

OSDs Chris 2/5/25

Count	Code	Description	RMV	Code Area	Exception
2	SAF	SA OSD - FAIR	35000	05545	0

1.0 HS 2BISS
26.68 Farm 2BISS
1.0 HS 4BISS
1.32 Farm 4BISS

Land ✓

Site: 3	Code Area: 05545	Size: 1.00 Acres	Use Code: 005	Zone: REST	SAV Use: 011	Exception: 0
Class:	Value Source: Farm Homesite	Description:			RMV: 11820	Exception: Y N
Adjustment(s):	GSOIL, IRR		Fire Patrol:		Description:	
Comments:	Liability year - 2009 / 550040					
Site: 4	Code Area: 05545	Size: 28.00 Acres	Use Code: 005	Zone: REST	SAV Use: 011	Exception: 0
Class: 2BISS	Value Source: Farm Use - EFU	Description: TWO BENCH IRR SOUTH SPECIAL			RMV: 380630	Exception: Y N
Adjustment(s):	GSOIL, IRR		Fire Patrol:		Description:	
Comments:	Liability year - 1980 / 550040					
Site: 5	Code Area: 05545	Size: 1.00 Acres	Use Code: 005	Zone: REST	SAV Use: 011	Exception: 0
Class:	Value Source: Farm Homesite	Description:			RMV: 11820	Exception: Y N
Adjustment(s):	GSOIL, IRR		Fire Patrol:		Description:	
Comments:	Liability year - 2009 / 550040					

Improvements - Residence / Manufactured Structures

Bldg: 3	Code Area: 05545	Stat Class: 128	Year Blt: 1989	Eff Year Blt: 1977	Sq.Ft: 0	% Complete: 100
Desc:	Res other improvements				Dimensions:	RMV: 27380
Func Obsc: 100	Econ %: 100	Other %: 100	Exception: 0	Adjust:	Adjust RMV: 0	

Floors

Type	Class	Display Group	Floor Size	Beds	Baths	Yr Blt	Eff Yr Blt	Inventory
Garage Attached	2	Unfinished	384	0	0	1989	1977	ROOF

Accessories

Description	Class	Size SqFt	Eff Yr Blt	RMV	Quantity
YARD IMPROVEMENTS FAIR	3	1	1977	7161	1

Bldg: 5	Code Area: 05545	Stat Class: 457 +	Year Blt: 1985	Eff Year Blt: 1985	Sq.Ft: 1296	% Complete: 100
Desc:	MANUF STRUCT, CLASS 5, 26' THROUGH 28' WIDE DOUBLE				Dimensions: 48x27,	RMV: 29950
Func Obsc: 100	Econ %: 100	Other %: 100	Exception: 0	Adjust:	Adjust RMV: 0	

Floors

Type	Class	Display Group	Floor Size	Beds	Baths	Yr Blt	Eff Yr Blt	Inventory
First Floor	5 +	Finished	1296	3	FB-2	1985	1985	KIT-, HVAC+, ROOF+, SKRT+

Accessories

Description	Class	Size SqFt	Eff Yr Blt	RMV	Quantity
No accessory data available					

Improvements - Accessory Buildings

Bldg: 1	Code Area: 05545	Stat Class: 341	Year Blt: 1971	Eff Year Blt: 1971	Sq.Ft: 240	% Complete: 100
Desc:	Multi Purpose Shed (MP)				Dimensions: 20x12	RMV: 1090
Func Obsc: 100	Econ %: 100	Other %: 100	Exception: 0	Adjust:	Adjust RMV: 0	

Floors

Type	Class	Display Group	Floor Size	Beds	Baths	Yr Blt	Eff Yr Blt	Inventory	
Multi-Purpose Bldg	4	Finished	240	0	0	1971	1971	FAIR	Exception: Y N

Accessories

Description	Class	Size SqFt	Eff Yr Blt	RMV	Quantity
No accessory data available					

Bldg: 2 Code Area: 05545 Stat Class: 341 Year Blt: 1971 Eff Year Blt: 1971 Sq.Ft: 240 % Complete: 100
 Desc: Multi Purpose Shed (MP) Dimensions: 20x12 RMV: 1090
 Func Obsc: 100 Econ %: 100 Other %: 100 Exception: 0 Adjust: Adjust RMV: 0

Floors

Type	Class	Display Group	Floor Size	Beds	Baths	Yr Blt	Eff Yr Blt	Inventory	
Multi-Purpose Bldg	4	Finished	240	0	0	1971	1971	FAIR	Exception: Y N

Accessories

Description	Class	Size SqFt	Eff Yr Blt	RMV	Quantity
No accessory data available					

Bldg: 4 Code Area: 05545 Stat Class: 351 Year Blt: 2009 Eff Year Blt: 2009 Sq.Ft: 2400 % Complete: 100
 Desc: General Purpose Building (GB) Dimensions: 40x60 RMV: 137960
 Func Obsc: 100 Econ %: 100 Other %: 100 Exception: 0 Adjust: Adjust RMV: 0

Floors

Type	Class	Display Group	Floor Size	Beds	Baths	Yr Blt	Eff Yr Blt	Inventory	
General Purpose Bldg	6	Finished	2400	0	0	2009	2009	AVB	Exception: Y N
GP Building Attic	6	Finished	2400	0	0	2009	2009	BATH - 1, AVG	Exception: Y N

Accessories

Description	Class	Size SqFt	Eff Yr Blt	RMV	Quantity
No accessory data available					

$$\begin{array}{r} \text{LTH} \\ \hline 19.5 \times 40 \\ 780 \text{ SF} \\ 2024 \text{ YR} \\ 6 \\ 85\% \text{ comp} \end{array}$$

$$\begin{array}{r} \text{LTH} \\ \hline 19.5 \times 36 \\ 702 \\ 2024 \\ 6 \\ 85\% \text{ comp} \end{array}$$

SKETCH/AREA TABLE ADDENDUM

SUBJECT INFO

File No.: 535533 Parcel No.: 092W24C 00900
 Property Address: 12793-12803 BRICK RD SE
 City: Salem County: Marion State: OR ZipCode: 97392
 Owner:
 Client: Client Address:
 Appraiser Name: Inspection Date:

SKETCH

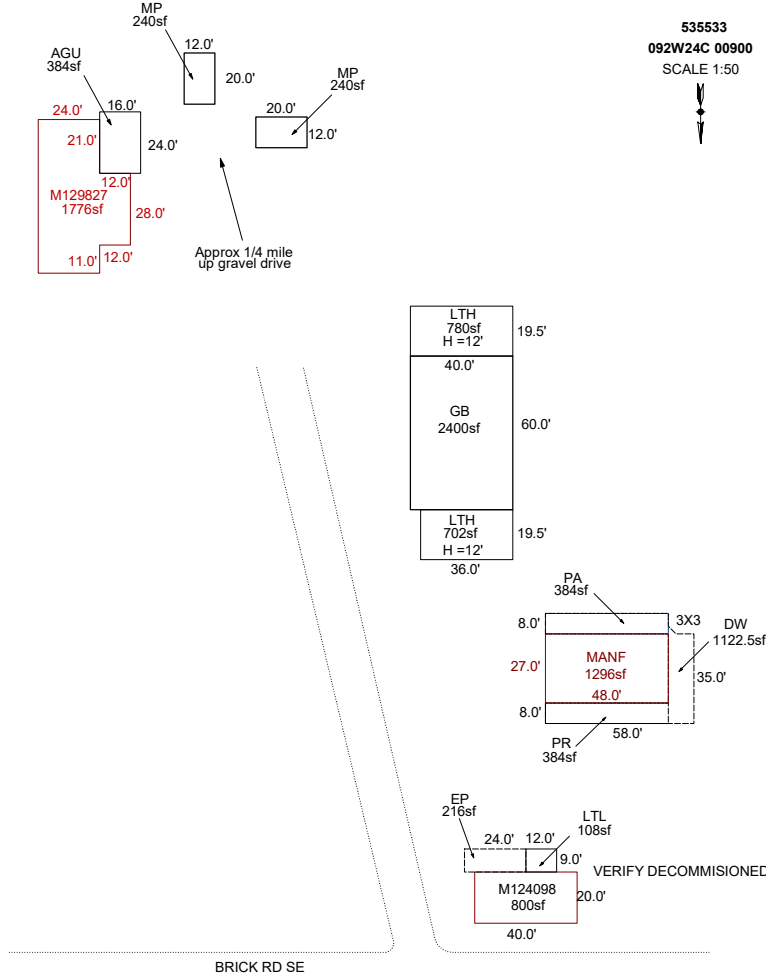

Sketch by ApexSketch

AREA CALCULATIONS SUMMARY

Code	Description	Factor	Net Size	Perimeter	Net Totals
GBA1	GB	1.0	2400.0	200.0	
	MP	1.0	240.0	64.0	
	MP	1.0	240.0	64.0	
	LTH	1.0	780.0	119.0	
	LTH	1.0	702.0	111.0	4362.0
GLA	MANF	1.0	1296.0	150.0	1296.0
GAR	AGU	1.0	384.0	80.0	384.0
OTH	M129827	1.0	1776.0	192.0	
	M124098	1.0	800.0	120.0	2576.0
P/P	EP	1.0	216.0	66.0	
	PA	1.0	384.0	112.0	
	DW	1.0	1122.5	296.2	
	PR	1.0	384.0	112.0	2106.5
		Net LIVABLE	cnt	1 (rounded)	
	Net BUILDING	cnt	5 (rounded)		4,362

COMMENT TABLE 1

APEX BY CJURAN 04/26/2021 555-20-008345
 UPDATED BY CLOBERG 09/13/24 24-005334 LTL GB
 UPDATED BY CLOBERG 01/30/25

COMMENT TABLE 2

MDL 12/12/24

COMMENT TABLE 3

TAGS L2

SKETCH/AREA TABLE ADDENDUM

SUBJECT INFO

File No.: 535533 Parcel No.: 092W24C 00900
 Property Address: 12793-12803 BRICK RD SE
 City: Salem County: Marion State: OR ZipCode: 97392
 Owner:
 Client: Client Address:
 Appraiser Name: Inspection Date:

SKETCH

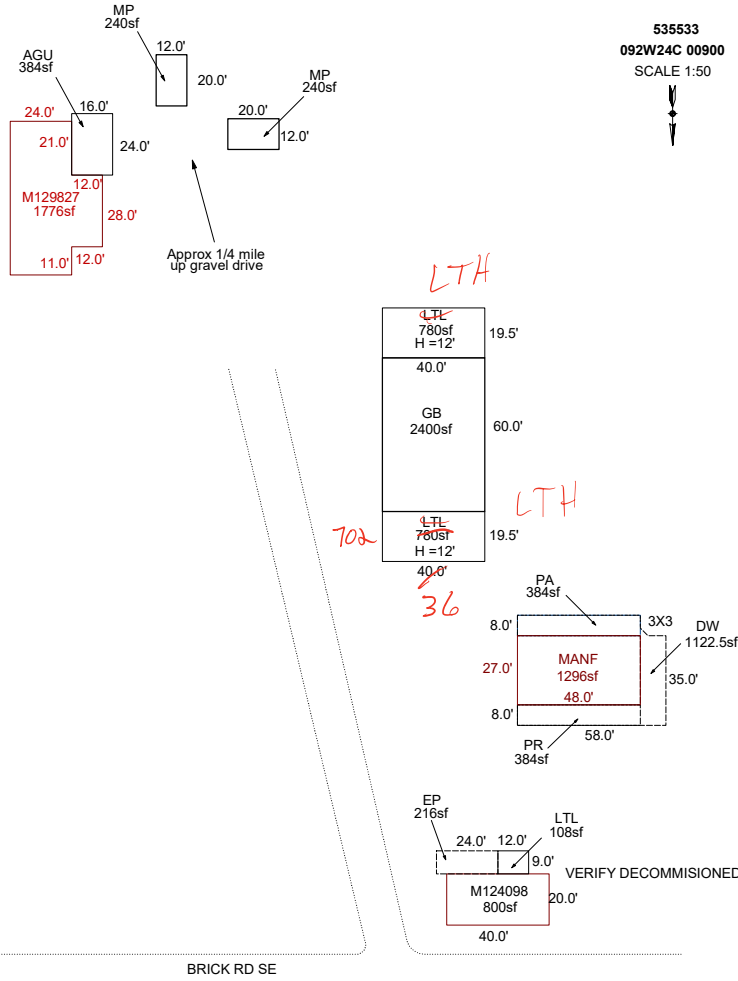

AREA CALCULATIONS SUMMARY

Code	Description	Factor	Net Size	Perimeter	Net Totals
GBA1	GB	1.0	2400.0	200.0	
	MP	1.0	240.0	64.0	
	MP	1.0	240.0	64.0	
	LTL	1.0	780.0	119.0	
	LTL	1.0	780.0	119.0	4440.0
GLA	MANF	1.0	1296.0	150.0	1296.0
GAR	AGU	1.0	384.0	80.0	384.0
OTH	M129827	1.0	1776.0	192.0	
	M124098	1.0	800.0	120.0	2576.0
P/P	EP	1.0	216.0	66.0	
	PA	1.0	384.0	112.0	
	DW	1.0	1122.5	296.2	
	PR	1.0	384.0	112.0	2106.5
	Net LIVABLE	cnt	1 (rounded)		1,296
	Net BUILDING	cnt	5 (rounded)		4,440

COMMENT TABLE 1

APEX BY CJURAN 04/26/2021 555-20-008345
 UPDATED BY CLOBERG 09/13/24 24-005334 LTL GB

COMMENT TABLE 2

COMMENT TABLE 3

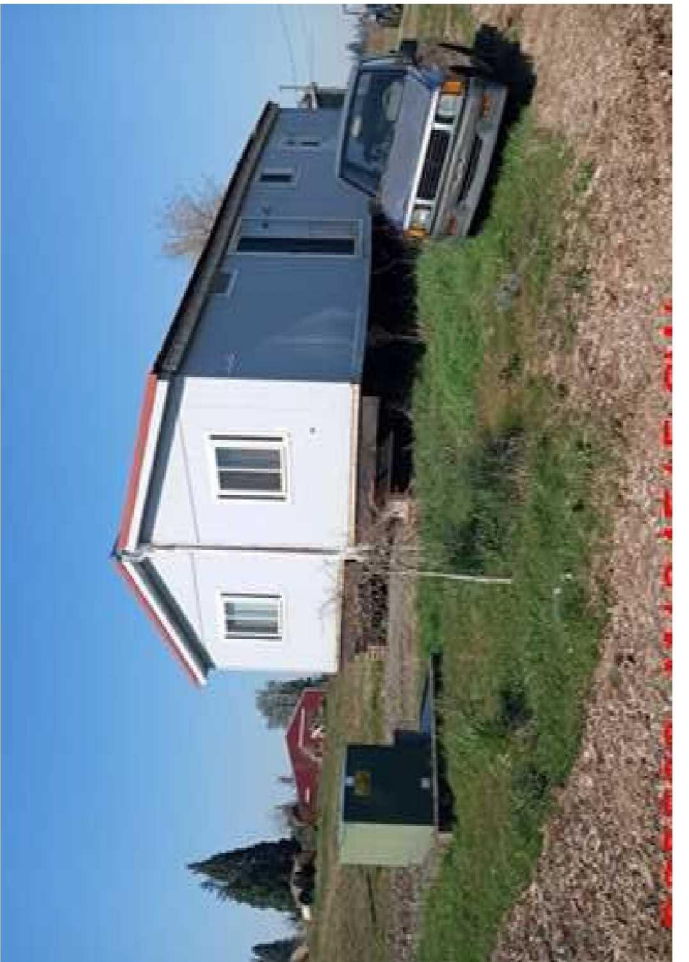



**535533 Manuf MA Front E Side
2021-09-28 L2**



**535533 Manuf 124098
2021-09-28 L2**



**535533 40x60 DGOF-DG2F
2021-09-28 L2**

Assessor Monthly Issued Permit Report

For 8/1/2024 to 8/31/2024

PERMIT#: 555-24-005334-STR STATUS: Permit Issued
 PERMIT TYPE: Residential APPLIED: 7/11/2024
 SUB-TYPE: Structural ISSUED: 8/28/2024
 CATEGORY: Comprehensive EXPIRES: 2/24/2025

OFFICE: MC

PARCEL#: 092W24C000900 M134515 535533

ACRES: 30

SUBDIV:

LOT/BLOCK: /

ADDRESS: 12793 BRICK RD SE TURNER, OR 97392

RELATIONSHIP	NAME	ADDRESS	PHONE
APPLICANT	KLINE, RICHARD W	PO BOX 324 MONMOUTH, OR 97361	503-917-9061
OWNER	KLINE, RICHARD W	PO BOX 324 MONMOUTH, OR 97361	
OWNER (PROPERTY)	SEE PROPERTY OWNER INFORMATION	OR	
SITE CONTACT	KLINE, RICHARD W	PO BOX 324 MONMOUTH, OR 97361	503-917-9061

CONST CAT: Detached Accessory Structure

WORK TYPE: Addition

WORK DESC: ADD 2 LEAN-TO TO EXISTING SHOP

VALUATION: \$42,679.70

STORIES: 0

BATHS:

KITCHENS:

SQUARE FEET

HABITABLE:

EXISTING: 0

NEW: 0

TOTAL SQ. FT.: 0

OCCUPANCY	CONSTRUCTION TYPE	SQ FT or # OF SPACES
U Utility, misc. - half rate	VB	1330 Sq Ft