

Summary Lead Appr: W W Clerk: _____ Lead Clerk: _____ Appr: MDC Taped Print Date: 9/26/2025

Acct ID: 536642 MTL: 093W340000200 Date: 11/30/25 Appr: MDC Prop Class: 551 RMV Prop Class: 451
 Situs: 14174 ANANONDA LN SE JEFFERSON OR 97352 MaSaNh: 07 06 000 Unit: 149101 Year: 2025

Last Date Appraised: 04/07/2025 Appraiser: MATT LORD Tag: Y N Tag info: 2026 - Tags/Permit (Addition)
 Owner: SMITH, TAYLOR Last Sales Date: 05/16/2024 Roll Type: R
 Cycle Tag Sales Verification Other: _____ Inspection level: 1 2 3 4 LCB TTO INSP AV: 197374
 RMV Land: 397750 RMV Imp: 286150 RMV Total: 683900 MAV: 181420 MSAV: 15954 SAV: 82392
 Comment: 25-26: L3 MDL 4.7.25 CYCLE 24-009732 GATED / NO ACRES left change

Notations 26-27: 438 Soft Enlarge Garage; Master Bath, work in lot C 100% complete

RP/MS	Code	Description
RP	ZONED	FARM EFU ZONED

CWO 12/29/15 Send inquiry letter unable to determine farm use

OSDs

Count	Code	Description	RMV	Code Area	Exception
1	SAA	SA OSD - AVERAGE	50000	14530	0

Land

Site	Code Area	Size	Use Code	Zone	SAV Use	Exception
Site: 2	Code Area: 14530	Size: 1.00 Acres	Use Code: 005	Zone: REST	SAV Use: 011	Exception: 0
Class: 2BDSS		Value Source: Farm Homesite		Description: TWO BENCH DRY SOUTH SPECIAL	RMV: 57280	Exception: Y N
Adjustment(s): GSOIL, IRR		Fire Patrol:		Description:		
Comments: Liability year - 2009 / //09-10: GW39 changed land type per Excel analysis// 81400130						
Site: 3	Code Area: 14530	Size: 0.15 Acres	Use Code: 005	Zone: REST	SAV Use: 011	Exception: 0
Class: 2BISS		Value Source: Farm Use - EFU		Description: TWO BENCH IRR SOUTH SPECIAL	RMV: 8980	Exception: Y N
Adjustment(s): GSOIL, IRR		Fire Patrol:		Description:		
Comments: Liability year - 2024						
Site: 4	Code Area: 14530	Size: 1.35 Acres	Use Code: 005	Zone: REST	SAV Use: 011	Exception: 0
Class: 2BISS		Value Source: Farm Use - EFU		Description: TWO BENCH IRR SOUTH SPECIAL	RMV: 80860	Exception: Y N
Adjustment(s): GSOIL, IRR		Fire Patrol:		Description:		
Comments: Liability year - 1980 / 81400130						
Site: 5	Code Area: 14530	Size: 3.35 Acres	Use Code: 005	Zone: REST	SAV Use: 011	Exception: 0
Class: 2BISS		Value Source: Farm Use - EFU		Description: TWO BENCH IRR SOUTH SPECIAL	RMV: 200630	Exception: Y N
Adjustment(s): GSOIL, IRR		Fire Patrol:		Description:		
Comments: Liability year - 1980 / 81400130						

Improvements - Residence / Manufactured Structures

Bldg: 1 Code Area: 14530 Stat Class: 141 - Year Blt: 1977 Eff Year Blt: 1977 Sq.Ft: 1608 % Complete: 100.00
 Desc: One Story Only Dimensions: _____ RMV: 264950
 Func Obsc: 100 Econ %: 100 Other %: 100 Exception: 0 Adjust: Adjust RMV: 0

Floors

Type	Class	Display Group	Floor Size	Beds	Baths	Yr Blt	Eff Yr Blt	Inventory	Exception
First Floor	4 -	Finished	1608 <u>204</u>	3	<u>2</u> FB-1 HB-1	1977	<u>1977</u>	HVAC+, ROOF, FP - 1, KIT-, BTH - 1, BATH - 1	Exception: <u>Y</u> N
Garage Attached	4	Finished	462 <u>226</u>	0	0	1977	<u>1977</u>	ROOF	Exception: <u>Y</u> N

Accessories

Description	Class	Size SqFt	Eff Yr Blt	RMV	Quantity
YARD IMPROVEMENTS AVERAGE	4	1	1977	24717	1

Exception: Y N

Improvements - Accessory Buildings

Bldg: 2 Code Area: 14530 Stat Class: 341 Year Blt: 1980 Eff Year Blt: 1980 Sq.Ft: 480 600 % Complete: 100.00
 Desc: Multi Purpose Shed (MP) GB Dimensions: 30x15 20 RMV: 5900
 Func Obsc: 100 Econ %: 100 Other %: 100 Exception: 0 Adjust: Adjust RMV: 0

Floors

Type	Class	Display Group	Floor Size	Beds	Baths	Yr Blt	Eff Yr Blt	Inventory	Exception
Multi-Purpose Bldg <u>GB</u>	6	Finished	480	0	HB-1	1980	1980	EXCLT, BTH - 1	Exception: Y N

Accessories

Description	Class	Size SqFt	Eff Yr Blt	RMV	Quantity
No accessory data available					

Bldg: 3 Code Area: 14530 Stat Class: 351 Year Blt: 1980 Eff Year Blt: 1980 Sq.Ft: 1920 % Complete: 100.00
 Desc: General Purpose Building (GB) Dimensions: 48x40 RMV: 8000
 Func Obsc: 100 Econ %: 100 Other %: 100 Exception: 0 Adjust: Adjust RMV: 0

Floors									
Type	Class	Display Group	Floor Size	Beds	Baths	Yr Blt	Eff Yr Blt	Inventory	
General Purpose Bldg	5	Finished	1920	0	0	1980	1980	FAIR	
Exception: Y N									

Accessories

Description	Class	Size SqFt	Eff Yr Blt	RMV	Quantity
No accessory data available					

Bldg: 4 Code Area: 14530 Stat Class: 355 Year Blt: 1980 Eff Year Blt: 1980 Sq.Ft: 1428 % Complete: 100.00
 Desc: Lean-to Heavy (LTH) Dimensions: RMV: 1930
 Func Obsc: 100 Econ %: 100 Other %: 100 Exception: 0 Adjust: Adjust RMV: 0

Floors									
Type	Class	Display Group	Floor Size	Beds	Baths	Yr Blt	Eff Yr Blt	Inventory	
Lean-to Heavy Duty	4	Finished	1428	0	0	1980	1980		
Exception: Y N									

Accessories

Description	Class	Size SqFt	Eff Yr Blt	RMV	Quantity
No accessory data available					

Bldg: 5 Code Area: 14530 Stat Class: 353 Year Blt: 1983 Eff Year Blt: 1983 Sq.Ft: 882 % Complete: 100.00
 Desc: Machine Shed (MS) Dimensions: 63x14 RMV: 2930
 Func Obsc: 100 Econ %: 100 Other %: 100 Exception: 0 Adjust: Adjust RMV: 0

Floors									
Type	Class	Display Group	Floor Size	Beds	Baths	Yr Blt	Eff Yr Blt	Inventory	
Machine Shed	5	Finished	882	0	0	1983	1983	FAIR	
Exception: Y N									

Accessories

Description	Class	Size SqFt	Eff Yr Blt	RMV	Quantity
No accessory data available					

Bldg: 6 Code Area: 14530 Stat Class: 341 Year Blt: Eff Year Blt: Sq.Ft: 0 % Complete: 100.00
 Desc: Multi Purpose Shed (MP) Dimensions: 10x8 RMV: 0
 Func Obsc: 100 Econ %: 100 Other %: 100 Exception: 0 Adjust: Adjust RMV: 0

Floors									
Type	Class	Display Group	Floor Size	Beds	Baths	Yr Blt	Eff Yr Blt	Inventory	
Multi-Purpose Bldg	5	Finished	0	0	0	0	0		
Exception: Y N									

Accessories

Description	Class	Size SqFt	Eff Yr Blt	RMV	Quantity
No accessory data available					

Bldg: 7 Code Area: 14530 Stat Class: 341 Year Blt: 2002 Eff Year Blt: 2002 Sq.Ft: 160 % Complete: 100.00
 Desc: Multi Purpose Shed (MP) Dimensions: 10x16 RMV: 2440
 Func Obsc: 100 Econ %: 100 Other %: 100 Exception: 0 Adjust: Adjust RMV: 0

Floors									
Type	Class	Display Group	Floor Size	Beds	Baths	Yr Blt	Eff Yr Blt	Inventory	
Multi-Purpose Bldg	5	Finished	160	0	0	2002	2002	FAIR	
Exception: Y N									

Accessories

Description	Class	Size SqFt	Eff Yr Blt	RMV	Quantity
No accessory data available					

SKETCH/AREA TABLE ADDENDUM

SUBJECT INFO

File No.: 536642 Parcel No.: 093W34 00200
 Property Address: 14174 ANANONDA LN SE
 City: JEFFERSON County: MARION State: OR ZipCode: 97352
 Owner:
 Client: Client Address:
 Appraiser Name: Inspection Date:

SKETCH

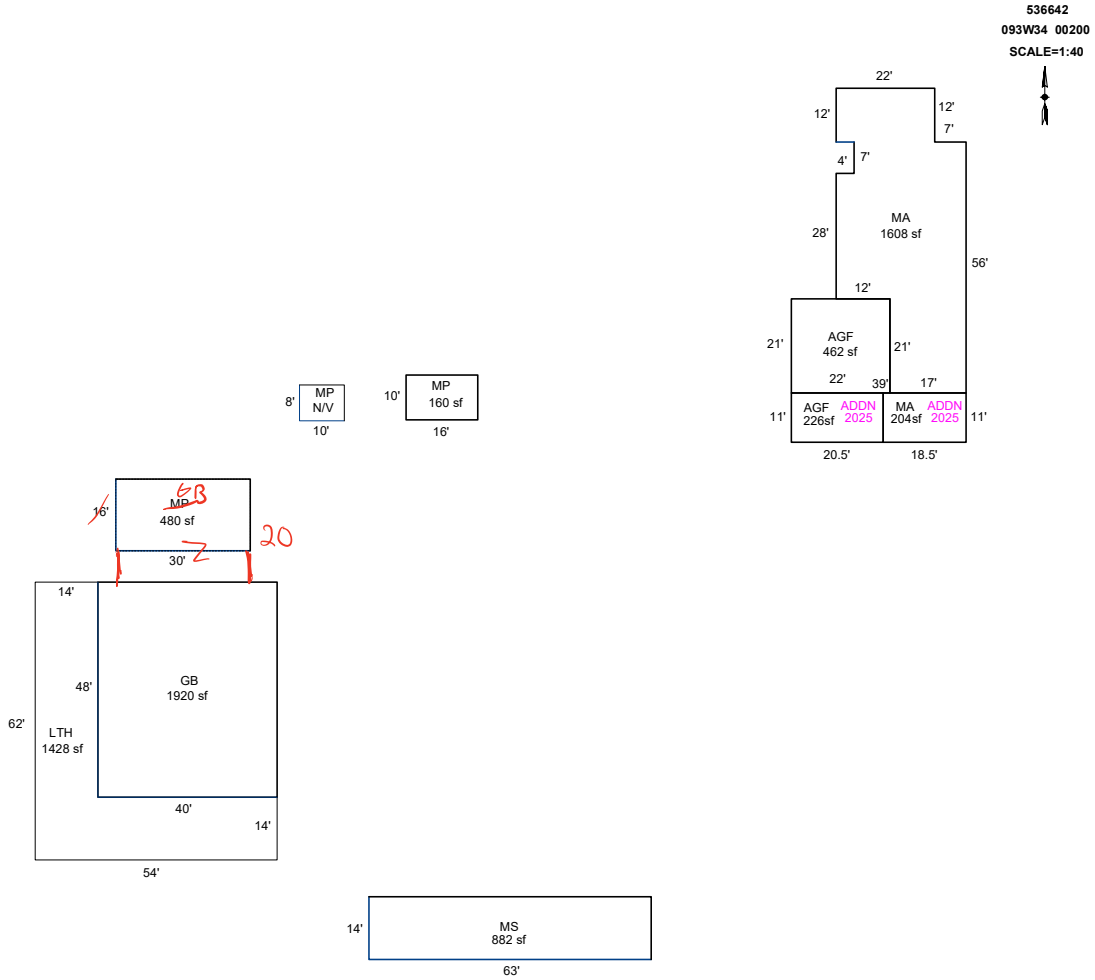

Sketch by ApexSketch

AREA CALCULATIONS SUMMARY

Code	Description	Factor	Net Size	Perimeter	Net Totals
GBA1	MP	1.0	480.0	92.0	
	GB	1.0	1920.0	176.0	
	LTH	1.0	1428.0	232.0	
	MP	1.0	160.0	52.0	
	MS	1.0	882.0	154.0	4870.0
GLA1	MA	1.0	1608.0	202.0	1608.0
GAR	AGF	1.0	462.0	86.0	
	AGF	1.0	225.5	63.0	687.5
MA	MA	1.0	203.5	59.0	203.5
	Net LIVABLE	cnt	1 (rounded)		1,812
	Net BUILDING	cnt	5 (rounded)		4,870

COMMENT TABLE 1

DRAWN BY JRONDEMA 6/27/18
 UPDATED BY CLOBERG 01/23/25 24-009732 ADDN
 UPDATED BY CLOBERG 07/16/25

COMMENT TABLE 2

MDL 04/07/25

COMMENT TABLE 3

CYCLE L3

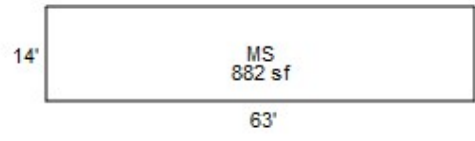
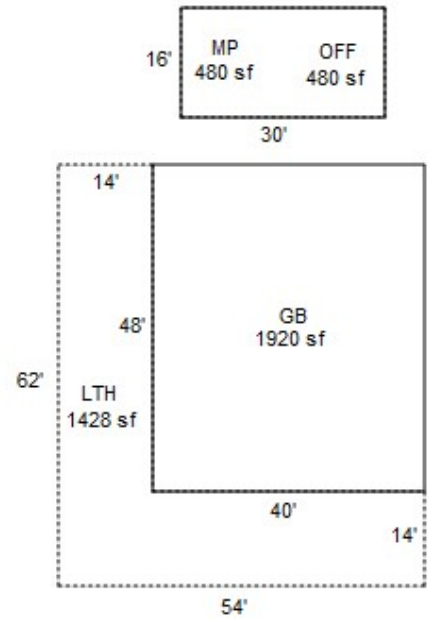
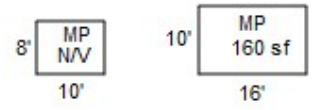
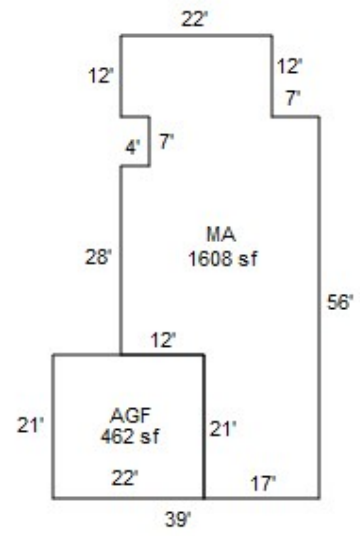

SKETCH/AREA TABLE ADDENDUM

SUBJECT INFO

File No.: 536642 Parcel No.: 093W34 00200
 Property Address: 14174 ANANONDA LN SE
 City: JEFFERSON County: MARION State: OR ZipCode: 97352
 Owner:
 Client: Client Address:
 Appraiser Name: Inspection Date:

SKETCH

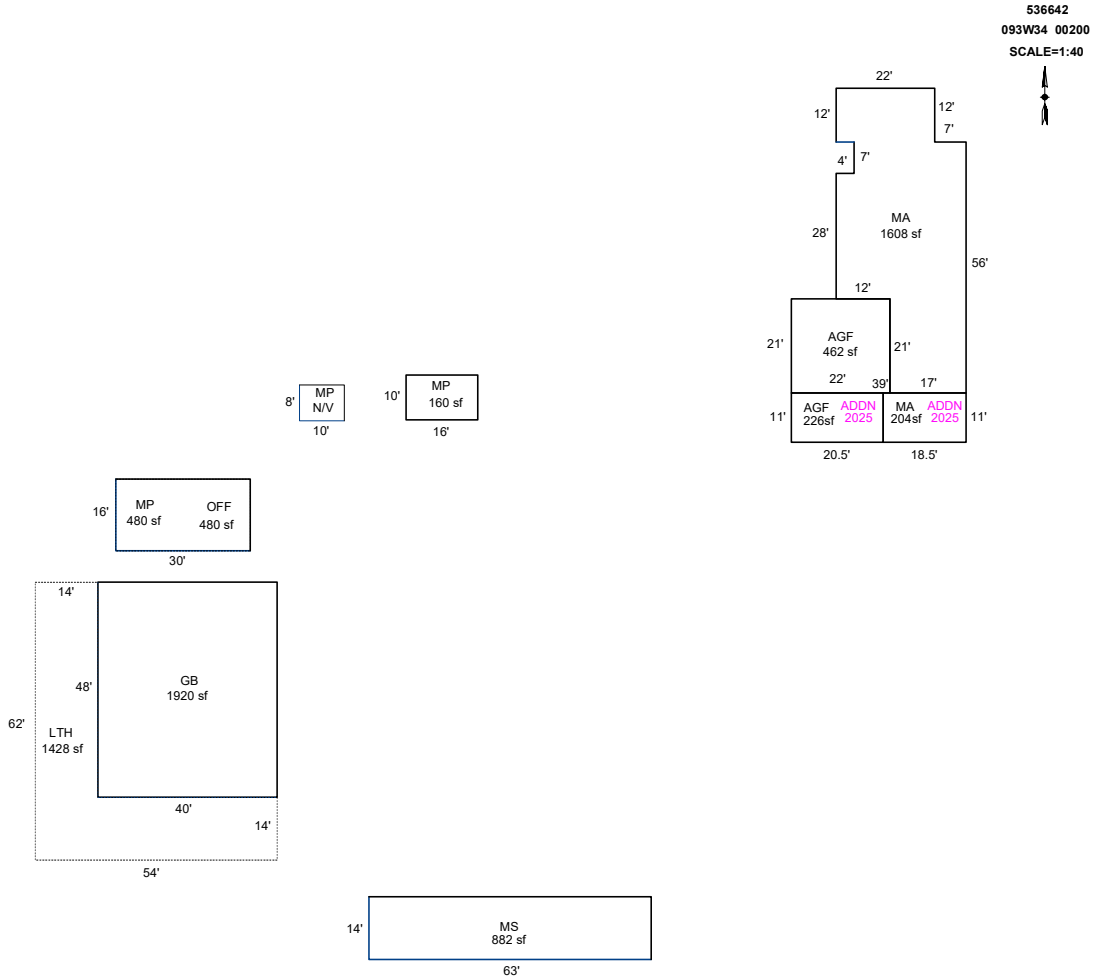

Sketch by ApexSketch

AREA CALCULATIONS SUMMARY

Code	Description	Factor	Net Size	Perimeter	Net Totals
GBA1	MP	1.0	480.0	92.0	
	GB	1.0	1920.0	176.0	
	LTH	1.0	1428.0	232.0	
	MP	1.0	160.0	52.0	
	MS	1.0	882.0	154.0	4870.0
GLA1	MA	1.0	1608.0	202.0	1608.0
GAR	AGF	1.0	462.0	86.0	
	AGF	1.0	225.5	63.0	687.5
MA	MA	1.0	203.5	59.0	203.5
	Net LIVABLE	cnt	1 (rounded)		1,812
	Net BUILDING	cnt	5 (rounded)		4,870

COMMENT TABLE 1

DRAWN BY JRONDEMA 6/27/18
 UPDATED BY CLOBERG 01/23/25 24-009732 ADDN

COMMENT TABLE 2

COMMENT TABLE 3









093W34 00200

R36642

551 02F A94

81400130

ANTRIM, JAMES F

4.35 Acres

ACRES 4.35, ANNEXATION NO 83-14

14174 ANANONDA LN SE

SKETCH/AREA TABLE ADDENDUM

Parcel No 093W34 00200

File No R36642

Property Address 14174 ANANONDA LN SE

City JEFFERSON

County MARION

State OR

Zip 97352

Owner

Client

Appraiser Name

SUBJECT

IMPROVEMENTS SKETCH

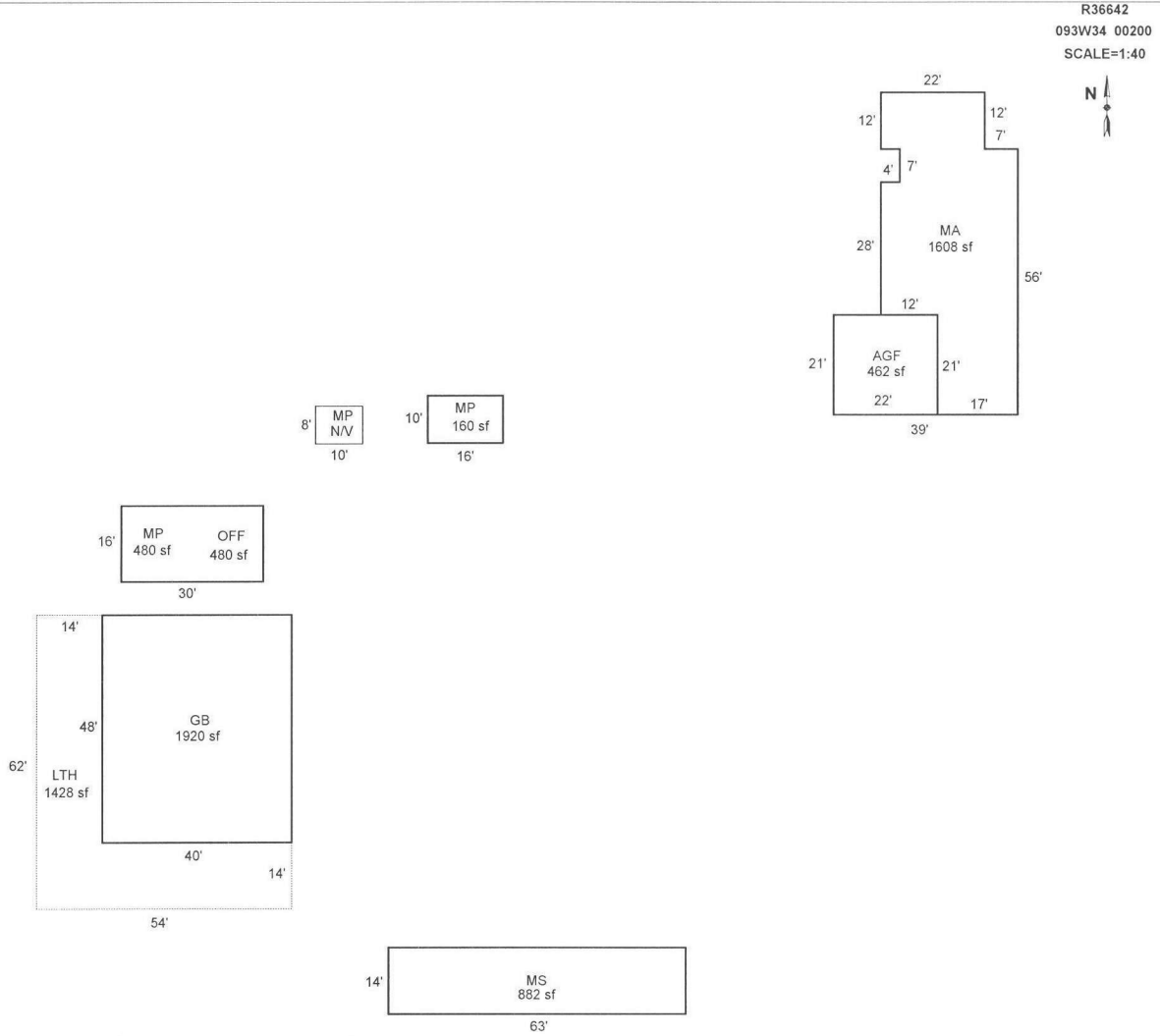

Scale: 1" = 40'

AREA CALCULATIONS

AREA CALCULATIONS SUMMARY

Code	Description	Factor	Net Size	Perimeter	Net Totals
GLA1	MA	1.00	1608	202	1608
GBA1	MP	1.00	480	92	
	GB	1.00	1920	176	
	LTH	1.00	1428	232	
	MP	1.00	160	52	
	MS	1.00	882	154	4870
GAR	AGF	1.00	462	86	462
Net LIVABLE Area		(rounded w/ factors)	1608		
Net BUILDING Area		(rounded w/ factors)	4870		

Comment Table 1

DRAWN BY JRONDEMA 6/27/18

Comment Table 2

Comment Table 3

R36642 093W34 00200 Prop Class: 551 Prop Code: A94 Fran: 73 Appr #: _____ Date: _____

Situs Address 14174 ANANONDA LN SE TTO LCB Insp Cycle Tags Farm Forest Sales Verif

Owner PROVIDENCE HOLDINGS-JEFFERSON LLC Pictom Other: _____

RMV Land: 65,720 RMV Imps: 177,460 RMV Total: 243,180 M50 Total: 159,370 For: 2017-2018

Notes: _____

Seg: 5.1 MS MACHINE SHED

Method: F09 Roof Cover: METAL Int Comp: Adj: FLCM

Class: 5 Roof Style: GABLE

Area: 882 Eff: 882 Flooring: DIRT

Dimens: 63 x 14 Plumbing: Electrical: % Comp: _____

Found: POST Heat/AC: Bedrooms: Func: _____

Ex. Wall BKENAM;10FT Fireplace: Year: Eff: 1983 Value: 2,780

Exc Code: _____ Comment/Adj: _____ L/S: _____

Seg: 6.1 MP MULTI/MISC PURPOSE BUILDING

Method: F;N Roof Cover: METAL Int Comp: Adj: FLCM

Class: 5 Roof Style: SHED

Area: 80 Eff: 80 Flooring: WOOD

Dimens: 10 x 8 Plumbing: Electrical: % Comp: _____

Found: FRAME Heat/AC: Bedrooms: Func: _____

Ex. Wall BKENAM;8FT Fireplace: Year: Eff: Value: 0

Exc Code: _____ Comment/Adj: _____ L/S: _____

Seg: 7.1 MP MP5

Method: F09 Roof Cover: METAL Int Comp: Adj: FLCM

Class: 5 Roof Style: SHED

Area: 160 Eff: 160 Flooring: WOOD

Dimens: 10 x 16 Plumbing: Electrical: % Comp: _____

Found: FRAME Heat/AC: Bedrooms: Func: _____

Ex. Wall PLYWD;10FT Fireplace: Year: 2002 Eff: 2002 Value: 2,160

Exc Code: _____ Comment/Adj: _____ L/S: _____

R36642 093W34 00200 Prop Class: 551 Prop Code: A94 Fran: 73 Appr #: 24 Date: 11-21-17

Situs Address 14174 ANANONDA LN SE TTO LCB Insp Cycle Tags Farm Forest Sales Verif
Owner PROVIDENCE HOLDINGS-JEFFERSON LLC Pictom Other:

RMV Land: 65,720 RMV Imps: 177,460 RMV Total: 243,180 M50 Total: 159,370 For: 2017-2018

Notes: N/C

Seg: 1.1 MA RESIDENTIAL
Method: R05 Roof Cover: ARCOMP Int Comp: RNG;DW Adj: RLCM4;R4-QLTY
Class: 4 Roof:
Area: 1608 Eff 1608 Flooring:
Dimens: x Plumbing: BATH1.5 Electrical: % Comp: _____
Found: Heat/AC: HP Bedrooms: 3 Func: _____
Ex Wall: Fireplace: HRTH-P Year: 1977 Eff: 1977 RMV: 114,410
Exc Code: Comment/Adj: L/S: _____

Seg: 1.2 AGF RESIDENTIAL
Method: R05 Roof Cover: ARCOMP Int Comp: Adj: RLCM4
Class: 4 Roof:
Area: 462 Eff 462 Flooring:
Dimens: 22 x 21 Plumbing: Electrical: % Comp: _____
Found: Heat/AC: Bedrooms: Func: _____
Ex Wall: Fireplace: Year: 1977 Eff: 1977 RMV: 24,730
Exc Code: Comment/Adj: L/S: _____

Accessory Improvements

Seg: 1.3 YI4A RESIDENTIAL
Method: R05 Roof Cover: Int Comp: Adj:
Class: Roof Style:
Area: 1 Eff: 1 Flooring:
Dimens: x Plumbing: Electrical: % Comp: _____
Found: Heat/AC: Bedrooms: Func: _____
Ex Wall: Fireplace: Year: Eff: RMV: 10,000
Exc Code: Comment/Adj: L/S: _____

Out Buildings

Seg: 2.1 MP MULTI/MISC PURPOSE BUILDING
Method: F09 Roof Cover: METAL Int Comp: Adj: FLCM
Class: 6 Roof Style: GABLE
Area: 480 Eff: 480 Flooring: CONC
Dimens: 30 x 16 Plumbing: Electrical: % Comp: _____
Found: CONC Heat/AC: Bedrooms: Func: _____
Ex. Wall PLYWD;8FT Fireplace: Year: Eff: 1980 Value: 3,180
Exc Code: Comment/Adj: L/S: _____

Seg: 2.2 OFF MULTI/MISC PURPOSE BUILDING
Method: F09 Roof Cover: Int Comp: Adj: FLCM
Class: Roof Style:
Area: 480 Eff: 480 Flooring:
Dimens: 16 x 30 Plumbing: BATH.5 Electrical: % Comp: _____
Found: Heat/AC: Bedrooms: Func: _____
Ex. Wall Fireplace: Year: Eff: 2007 Value: 10,890
Exc Code: Comment/Adj: L/S: _____

Seg: 3.1 GB GENERAL PURPOSE BUILDING
Method: F09 Roof Cover: METAL Int Comp: Adj: FLCM
Class: 5 Roof Style: GABLE
Area: 1920 Eff: 1920 Flooring: CONC
Dimens: 48 x 40 Plumbing: Electrical: % Comp: _____
Found: CONC Heat/AC: Bedrooms: Func: _____
Ex. Wall 14FT;METAL Fireplace: Year: Eff: 1980 Value: 7,340
Exc Code: Comment/Adj: L/S: _____

Seg: 4.1 LTH LEAN-TO
Method: F09 Roof Cover: METAL Int Comp: Adj: FLCM
Class: Roof Style: SHED
Area: 1428 Eff: 1428 Flooring: DIRT
Dimens: x Plumbing: Electrical: % Comp: _____
Found: POST Heat/AC: Bedrooms: Func: _____
Ex. Wall BKENAM;8FT Fireplace: Year: Eff: 1980 Value: 1,970
Exc Code: Comment/Adj: L/S: _____

468



9300 34 200

Marion County

OREGON

ASSESSOR'S OFFICE

September 18, 2006

VAN METER, RONALD E
9720 SE 362ND AV
BORING, OR 97009

RE: ACCOUNT NUMBER(S) - R36642, R36643

ASSESSOR
(503) 588-5144
(503) 588-7985 (FAX)

**BOARD OF
COMMISSIONERS**
Janet Carlson
Patti Milne
Sam Brentano
(503) 588-5212

**CHIEF
ADMINISTRATIVE
OFFICER**
John Lattimer
(503) 588-5212

WEBSITE
www.co.marion.or.us

Our records show that you recently purchased this property, and it is currently receiving special assessment under our Zoned Farmland deferral program. This program requires the land be used exclusively in a bona fide farm operation for the purpose of producing a profit in monies. The land must be used primarily for farming purposes.

Enclosed is a flyer describing the requirements of this deferral program for your reference. We are not taking any action and it is not necessary that you contact us at this time. This notice is merely being provided to you as a courtesy, so that you understand your obligations if you wish to retain special assessment under this deferral program.

If you have further questions about this Special Assessment program, feel free to contact our office at (503) 588-5049.

SINCERELY,

MARION COUNTY ASSESSOR'S OFFICE
SPECIAL ASSESSMENT SECTION

Specially Assessed Land Appraisal Card

Account: R36642

Map Tax Lot: 093W34 00200

Name: PROVIDENCE HOLDINGS-JEF1900 FRONT

Acres: 4.35

Franchise: 24

ST NE SALEM, OR 97301

Related Accounts:

LSU	Year	Mthd	Lsu Code	LSU Description	Acres	Schedule	RMV	SAV	MSAV	
Y99	LT		1001	FARM OSD	0.00	OSDA.RUR	40,000	4,000	4,000	R36642.1
Y09	HS		1021	FARM HOMESITE	1.00	008S	4,180	6,190	3,930	R36642.2
Y80	ASU		3220	TWO BENCH IRR	3.35	008SGI	21,540	9,370	3,900	R36642.3

Inspection Date: 5, 1, 18

Remarks: Farm use ok - Nursery stock

5/14/18
JEM

#24 AG

Specially Assessed Land Appraisal Card

Account: R36642

Map Tax Lot: 093W34 00200

Name: PROVIDENCE HOLDINGS-JEF1900 FRONT
ST NE SALEM, OR 97301

Acres: 4.35

Franchise: 24

Related Accounts:

Event Code	Date	Comment	R36642	R36642
2017FARM	4/14/2017	DEC 2017 - SENT NEW OWNER SALES COURTESY LETTER & FLYERS/CW/ 17-18: #73 ONSITE 4-5-17, FARM USE OK		
FARMSALE	2/15/2017	FEB 2017: THIS SPECIALLY ASSESSED PROPERTY CHANGED HANDS APPROX A YEAR AGO, PLEASE CHECK FOR CURRENT FARM/FOREST USE		
2016FARM	6/17/2016	JUNE 2016 - SENT NEW OWNER SALES COURTESY LETTER & FLYERS		



8-27-08

8x10

16x10



8-27-08

14x63





27 7'98

Summary Lead Appr: Clerk: Lead Clerk: Appr: MNL Input Print Date: 1/25/2024

Acct ID: 536642 MTL: 093W340000200 Date: 4/7/25 Appr: MNL Prop Class: 551 RMV Prop Class: 551
Situs: 14174 ANANONDA LN SE JEFFERSON OR 97352 MaSaNh: 07 06 000 Unit: 95105 Year: 2024

Last Date Appraised: 11/21/2017 Appraiser: MATT LORD Retag: Y (N) Tag info: Roll Type: R

Owner: PROVIDENCE HOLDINGS-JEFFERSON LLC
Cycle Tag Sales Verification Other: Inspection level: 1 2 3 4 LCB TTO INSP AV: 189365

RMV Land: 64510 RMV Imp: 248460 RMV Total: 312970 MAV: 176140 MSAV: 13465 SAV: 22594

Comment: Farming crops

Notations 25.06 cycle

RP/MS	Code	Description
RP	ZONED	FARM EFU ZONED

OSDs

Count	Code	Description	RMV	Code Area	Exception
1	SAA	SA OSD - AVERAGE	45000	14530	0

Land

Site: 2 Code Area: 14530 Size: 1.00 Acres Use Code: 005 Zone: REST SAV Use: 011 Exception: 0
Class: 2BDS Value Source: Farm Homesite Description: TWO BENCH DRY SOUTH SPECIAL RMV: 4330 Exception: Y N
Adjustment(s): GSOIL, IRR Fire Patrol: Description:
Comments: Liability year - 2009 // /09-10: GW39 changed land type per Excel analysis// 81400130

Site: 3 Code Area: 14530 Size: 3.35 Acres Use Code: 005 Zone: REST SAV Use: 011 Exception: 0
Class: 2BISS Value Source: Farm Use - EFU Description: TWO BENCH IRR SOUTH SPECIAL RMV: 15180 Exception: Y N
Adjustment(s): GSOIL, IRR Fire Patrol: Description:
Comments: Liability year - 1980 / 81400130

Improvements - Residence / Manufactured Structures

Bldg: 1 Code Area: 14530 Stat Class: 141 - Year Blt: 1977 Eff Year Blt: 1977 Sq.Ft: 1608 % Complete: 100
Desc: One Story Only Dimensions: RMV: 217490
Func Obsc: 100 Econ %: 100 Other %: 100 Exception: 0 Adjust: Adjust RMV: 0

Floors

Type	Class	Display Group	Floor Size	Beds	Baths	Yr Blt	Eff Yr Blt	Inventory	Exception
First Floor	4 -	Finished	1608	3	FB-1/ HB-1	1977	1977	BATH - 1, BTH - 1, KIT-, HVAC+, FP - 1, ROOF	Exception: Y N
Garage Attached	4	Finished	462	0	0	1977	1977	ROOF	Exception: Y N

Accessories

Description	Class	Size SqFt	Eff Yr Blt	RMV	Quantity	Exception
YARD IMPROVEMENTS AVERAGE	4	1	1977	21483	1	Exception: Y N

Improvements - Accessory Buildings

Bldg: 2 Code Area: 14530 Stat Class: 341 Year Blt: 1980 Eff Year Blt: 1980 Sq.Ft: 967400 RMV: 16200
Desc: Multi-Purpose Shed (MP) 6B Dimensions: 30x16
Func Obsc: 100 Econ %: 100 Other %: 100 Exception: 0 Adjust: Adjust RMV: 0

Floors

Type	Class	Display Group	Floor Size	Beds	Baths	Yr Blt	Eff Yr Blt	Inventory	Exception
Finished Office	6	Finished	480	0	FB-1/ HB-1	2007	2007	BTH - 1, FAIR	Exception: Y N
Multi-Purpose Bldg	6	Finished	480	0	0	1980	1980	600D	Exception: Y N

Accessories

Description	Class	Size SqFt	Eff Yr Blt	RMV	Quantity
No accessory data available					

Bldg: 3 Code Area: 14530 Stat Class: 351 Year Blt: 1980 Eff Year Blt: 1980 Sq.Ft: 1920 % Complete: 100
Desc: General Purpose Building (GB) Dimensions: 48x40 RMV: 8000
Func Obsc: 100 Econ %: 100 Other %: 100 Exception: 0 Adjust: Adjust RMV: 0

Floors

Type	Class	Display Group	Floor Size	Beds	Baths	Yr Blt	Eff Yr Blt	Inventory	Exception
General Purpose Bldg	5	Finished	1920	0	0	1980	1980	FAIR ✓	Exception: Y N

Accessories

Description	Class	Size SqFt	Eff Yr Blt	RMV	Quantity
No accessory data available					

Bldg: 4 Code Area: 14530 Stat Class: 355 Year Blt: 1980 Eff Year Blt: 1980 Sq.Ft: 1428 % Complete: 100
 Desc: Lean-to Heavy (LTH) ✓
 Dimensions: RMV: 1930
 Func Obsc: 100 Econ %: 100 Other %: 100 Exception: 0 Adjust: Adjust RMV: 0

Floors

Type	Class	Display Group	Floor Size	Beds	Baths	Yr Blt	Eff Yr Blt	Inventory
Lean-to Heavy Duty	4	Finished	1428	0	0	1980	1980	Exception: Y N

Accessories

Description	Class	Size SqFt	Eff Yr Blt	RMV	Quantity
No accessory data available					

Bldg: 5 Code Area: 14530 Stat Class: 353 Year Blt: 1983 Eff Year Blt: 1983 Sq.Ft: 882 % Complete: 100
 Desc: Machine Shed (MS)
 Dimensions: 63x14 RMV: 2690
 Func Obsc: 100 Econ %: 100 Other %: 100 Exception: 0 Adjust: Adjust RMV: 0

Floors

Type	Class	Display Group	Floor Size	Beds	Baths	Yr Blt	Eff Yr Blt	Inventory
Machine Shed	5	Finished	882	0	0	1983	1983	FAIR Exception: Y N

Accessories

Description	Class	Size SqFt	Eff Yr Blt	RMV	Quantity
No accessory data available					

Bldg: 6 Code Area: 14530 Stat Class: 341 Year Blt: Eff Year Blt: Sq.Ft: 80 % Complete: 100
 Desc: Multi Purpose Shed (MP)
 Dimensions: 10x8 RMV: 0
 Func Obsc: 100 Econ %: 100 Other %: 100 Exception: 0 Adjust: Adjust RMV: 0

Floors

Type	Class	Display Group	Floor Size	Beds	Baths	Yr Blt	Eff Yr Blt	Inventory
Multi-Purpose Bldg	5	Finished	80	0	0	0	0	Exception: Y N

Accessories

Description	Class	Size SqFt	Eff Yr Blt	RMV	Quantity
No accessory data available					

Bldg: 7 Code Area: 14530 Stat Class: 341 Year Blt: 2002 Eff Year Blt: 2002 Sq.Ft: 160 % Complete: 100
 Desc: Multi Purpose Shed (MP)
 Dimensions: 10x16 RMV: 2150
 Func Obsc: 100 Econ %: 100 Other %: 100 Exception: 0 Adjust: Adjust RMV: 0

Floors

Type	Class	Display Group	Floor Size	Beds	Baths	Yr Blt	Eff Yr Blt	Inventory
Multi-Purpose Bldg	5	Finished	160	0	0	2002	2002	FAIR Exception: Y N

Accessories

Description	Class	Size SqFt	Eff Yr Blt	RMV	Quantity
No accessory data available					

SKETCH/AREA TABLE ADDENDUM

SUBJECT INFO

File No.: 536642 Parcel No.: 093W34 00200
 Property Address: 14174 ANANONDA LN SE
 City: JEFFERSON County: MARION State: OR ZipCode: 97352
 Owner:
 Client: Client Address:
 Appraiser Name: Inspection Date:

SKETCH

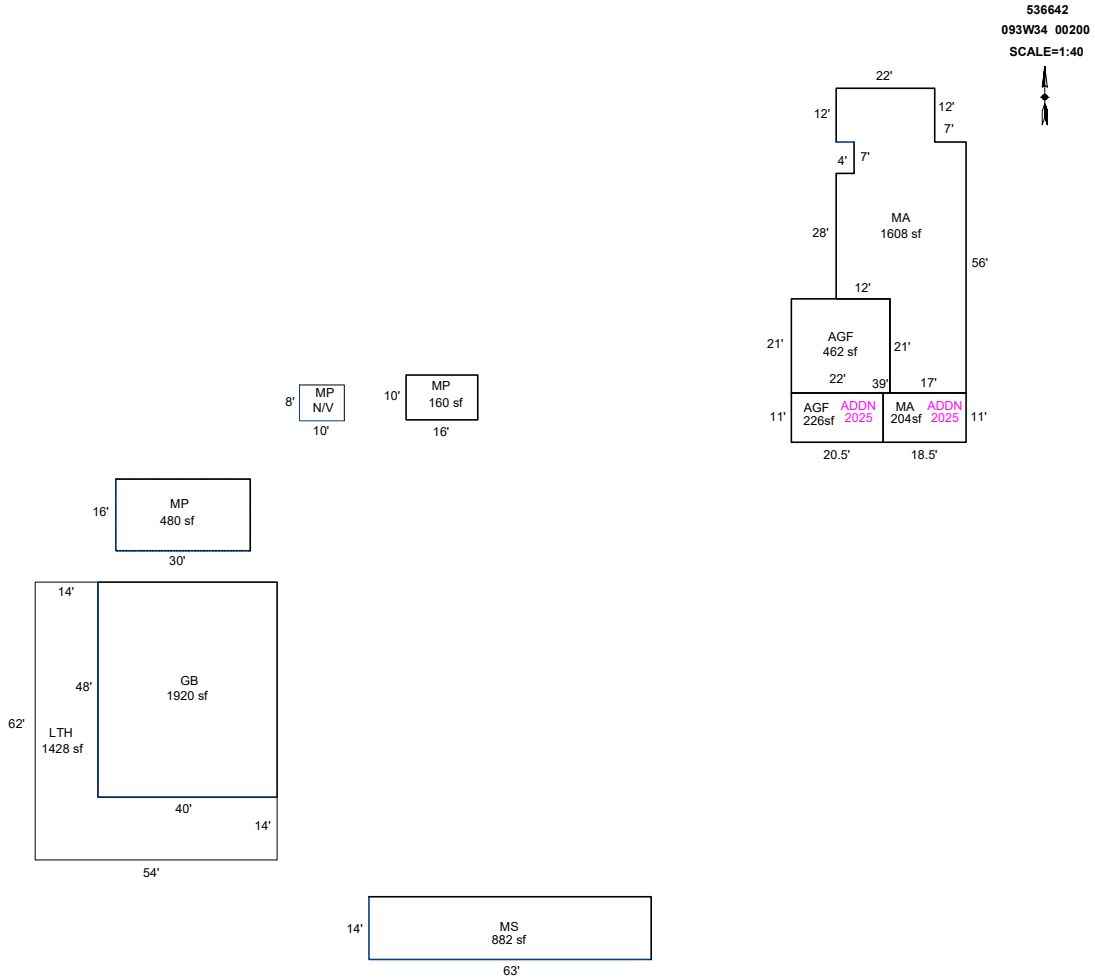

Sketch by ApexSketch

AREA CALCULATIONS SUMMARY

Code	Description	Factor	Net Size	Perimeter	Net Totals
GBA1	MP	1.0	480.0	92.0	
	GB	1.0	1920.0	176.0	
	LTH	1.0	1428.0	232.0	
	MP	1.0	160.0	52.0	
	MS	1.0	882.0	154.0	4870.0
GLA1	MA	1.0	1608.0	202.0	1608.0
GAR	AGF	1.0	462.0	86.0	
	AGF	1.0	225.5	63.0	687.5
MA	MA	1.0	203.5	59.0	203.5
Net LIVABLE		cnt	1 (rounded)		1,812
Net BUILDING		cnt	5 (rounded)		4,870

COMMENT TABLE 1

DRAWN BY JRONDEMA 6/27/18
 UPDATED BY CLOBERG 01/23/25 24-009732 ADDN
 UPDATED BY CLOBERG 07/16/25

COMMENT TABLE 2

MDL 04/07/25

COMMENT TABLE 3

CYCLE L3

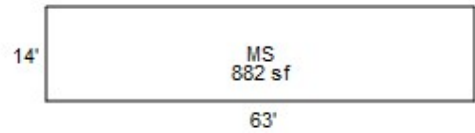
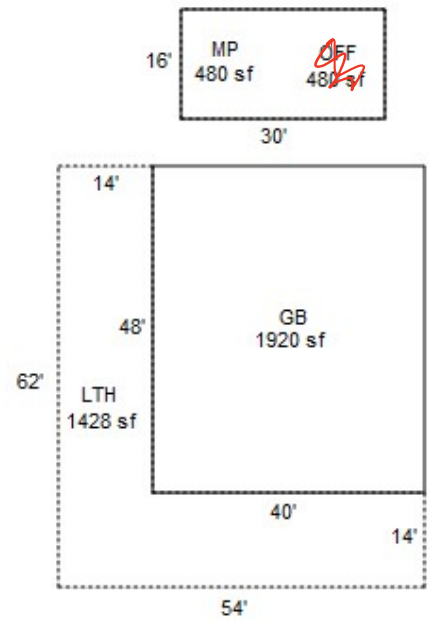
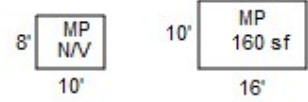
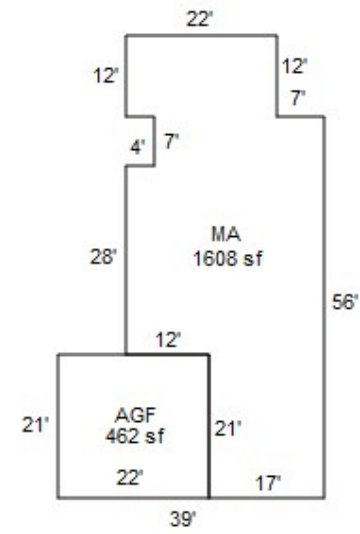









Assessor Monthly Issued Permit Report

For 12/1/2024 to 12/31/2024

PERMIT#: 555-24-009732-STR STATUS: Permit Issued
 PERMIT TYPE: Residential APPLIED: 12/13/2024
 SUB-TYPE: Structural ISSUED: 12/23/2024
 CATEGORY: Comprehensive EXPIRES: 6/21/2025

OFFICE: MC

PARCEL#: 093W340000200 R36642

ACRES: 5.85

SUBDIV:

LOT/BLOCK: /

ADDRESS: 14174 ANANONDA LN SE JEFFERSON, OR 97352

RELATIONSHIP	NAME	ADDRESS	PHONE
(QP) QUALIFIED PERSON	GARY POPE DESIGN & DRAFTING	31798 CHESTNUT LN LEBANON, OR. 97355	541 401-7266
APPLICANT	SMITH, TAYLOR	14174 ANANONDA LN SE JEFFERSON, OR 97352	541-650-1458
OWNER	SMITH, TAYLOR	14174 ANANONDA LN SE JEFFERSON, OR 97352	
OWNER (PROPERTY)	SEE PROPERTY OWNER INFORMATION	OR	
SITE CONTACT	SMITH, TAYLOR	14174 ANANONDA LN SE JEFFERSON, OR 97352	541-650-1458

CONST CAT: Single Family Dwelling

WORK TYPE: Alteration

WORK DESC: 438SQFT ADDITION TO ENLARGE GARAGE, ENLARGE BATHRM & CREATE WALK-IN CLOSET FOR MASTER BDRM

VALUATION: \$48,918.62

STORIES: 0

BATHS:

KITCHENS:

SQUARE FEET

HABITABLE: 0

EXISTING: 438

NEW: 0

TOTAL SQ. FT.: 438

OCCUPANCY	CONSTRUCTION TYPE	SQ FT or # OF SPACES
R-3 1 & 2 family	VB	205 Sq Ft
U Utility, misc.	VB	246 Sq Ft