

SKETCH/AREA TABLE ADDENDUM

SUBJECT INFO

File No.: 602462		Parcel No.: 081W34AD09700	
Property Address: 462 NE Cedar St			
City: Sublimity	County: Marion	State: OR	ZipCode: 97385
Owner:			
Client:		Client Address:	
Appraiser Name:		Inspection Date:	

SKETCH

602462
081W34AD09700

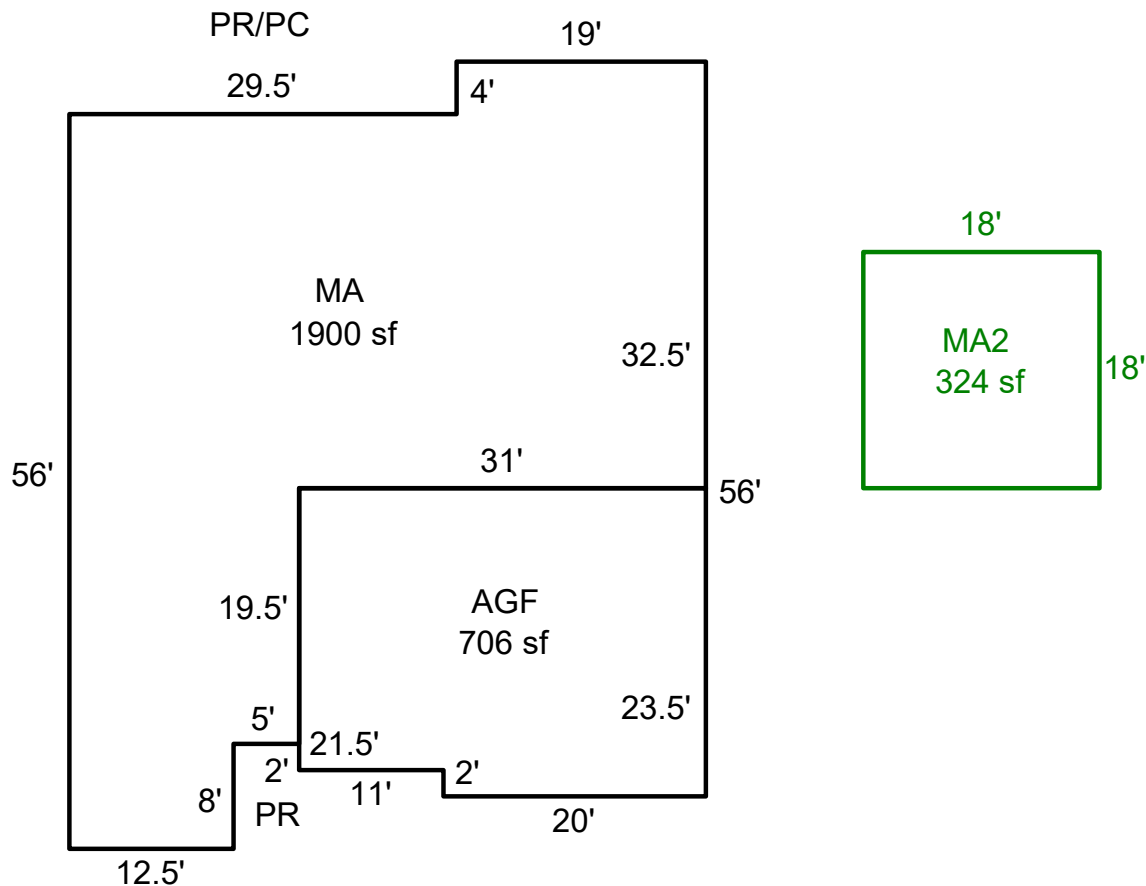

Sketch by ApexSketch

AREA CALCULATIONS SUMMARY

Code	Description	Factor	Net Size	Perimeter	Net Totals
GLA	MA	1.0	1899.5	217.0	1899.5
GLA2	MA2	1.0	324.0	72.0	324.0
GAR	AGF	1.0	706.5	109.0	706.5

COMMENT TABLE 1

Drawn by AE 1.15.26

COMMENT TABLE 2

COMMENT TABLE 3

Net LIVABLE	cnt	2	(rounded)		2,224
-------------	-----	---	-----------	--	-------