

# SKETCH/AREA TABLE ADDENDUM

## SUBJECT INFO

File No.: 332515 Parcel No.: 083W03AA10201  
 Property Address: 3285 Pheasant Ave SE  
 City: Salem County: Marion State: OR ZipCode: 97302  
 Owner:  
 Client: Client Address:  
 Appraiser Name: Inspection Date:

## SKETCH

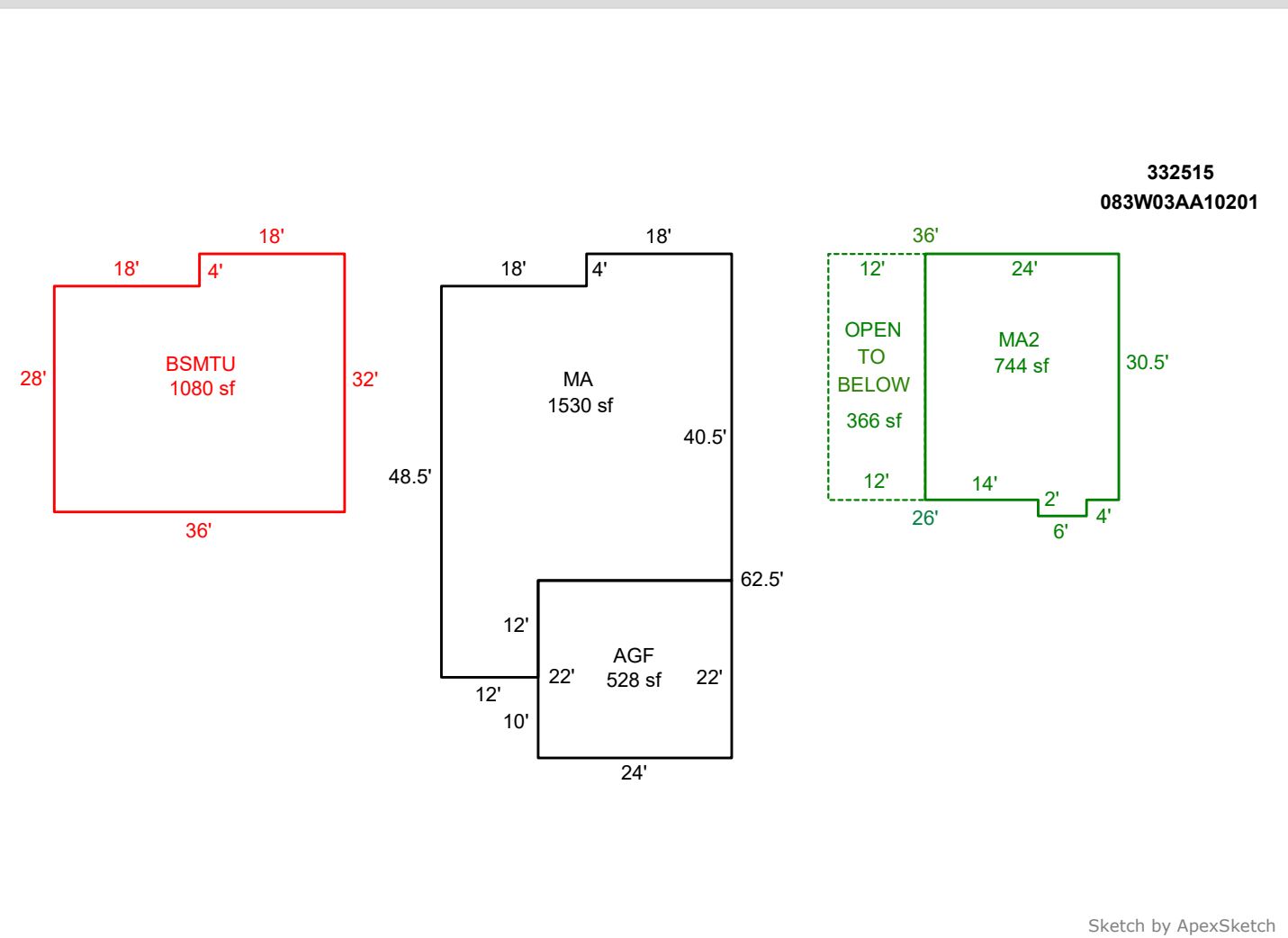

AREA CALCULATIONS SUMMARY						COMMENT TABLE 1		
Code	Description	Factor	Net Size	Perimeter	Net Totals			
GLA	MA	1.0	1530.0	177.0	1530.0	Drawn by AE 7.10.24 UPDATED BY LK 1.7.25		
GLA2	MA2	1.0	744.0	113.0	744.0			
BSMT	BSMTU	1.0	1080.0	136.0	1080.0			
GAR	AGF	1.0	528.0	92.0	528.0			
OTH	OPEN	1.0	366.0	85.0	366.0			
Net LIVABLE						cnt	2 (rounded)	2,274
						COMMENT TABLE 2	COMMENT TABLE 3	
						1-2-25 TAG GM		