

# SKETCH/AREA TABLE ADDENDUM

## SUBJECT INFO

File No.: 332548 Parcel No.: 083W08C 03203  
 Property Address: 2975 MARTINSON LN S  
 City: SALEM County: MARION State: OR ZipCode: 97302  
 Owner:  
 Client: Client Address:  
 Appraiser Name: Inspection Date:

## SKETCH



**332548**  
**083W08C 03203**  
 SCALE = 1:30

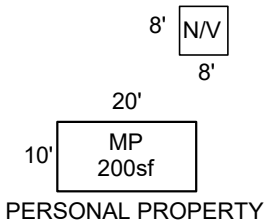
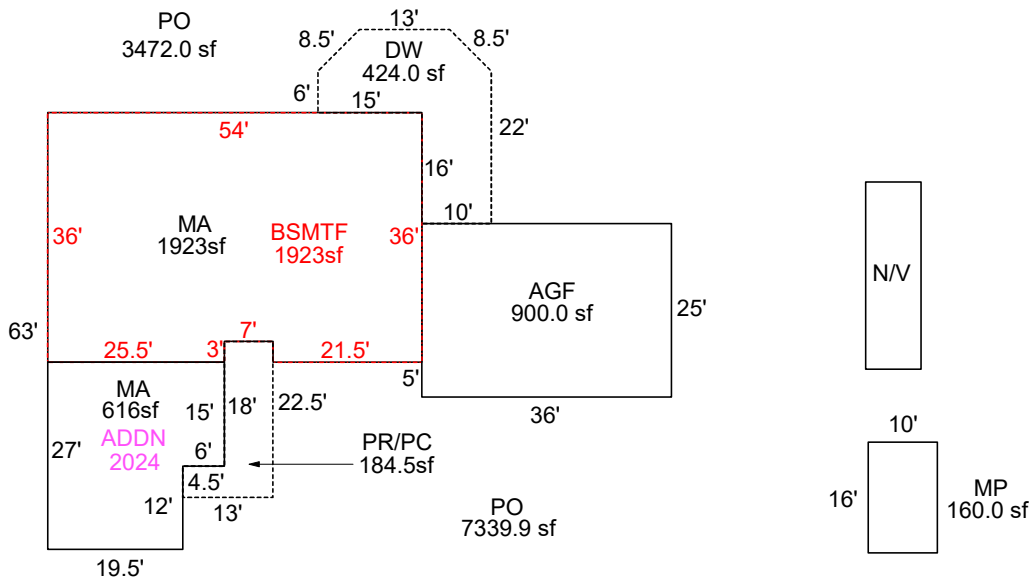

Sketch by ApexSketch

### AREA CALCULATIONS SUMMARY

Code	Description	Factor	Net Size	Perimeter	Net Totals
GBA1	MP	1.0	160.0	52.0	160.0
GLA0	BSMTF	1.0	1923.0	186.0	1923.0
GLA1	MA	1.0	1923.0	186.0	
	MA	1.0	616.5	105.0	2539.5
GAR	AGF	1.0	900.0	122.0	900.0
MP	MP	1.0	200.0	60.0	200.0
P/P	PR/PC	1.0	184.5	71.0	184.5

### COMMENT TABLE 1

DRAWN BY BB44  
 UPDATED BY CJURAN 03/12/2024 24-000526 ADDN  
 UPDATED BY CLOBERG 09/19/25 25-005328 CONV  
 UPDATED BY CLOBERG 02/20/26

### COMMENT TABLE 2

GRH 11/14/24  
 GRH 10/24/25

### COMMENT TABLE 3

TAGS L3  
 TAGS L2

Net LIVABLE            cnt            2    (rounded)            5,563  
 Net BUILDING        cnt            0    (rounded)            160