

SKETCH/AREA TABLE ADDENDUM

SUBJECT INFO

File No.: 609067 Parcel No.: 092W18B000701
 Property Address: 11061 WINTER WAY SE
 City: TURNER County: MARION State: OR ZipCode: 97392
 Owner:
 Client: Client Address:
 Appraiser Name: Inspection Date:

SKETCH

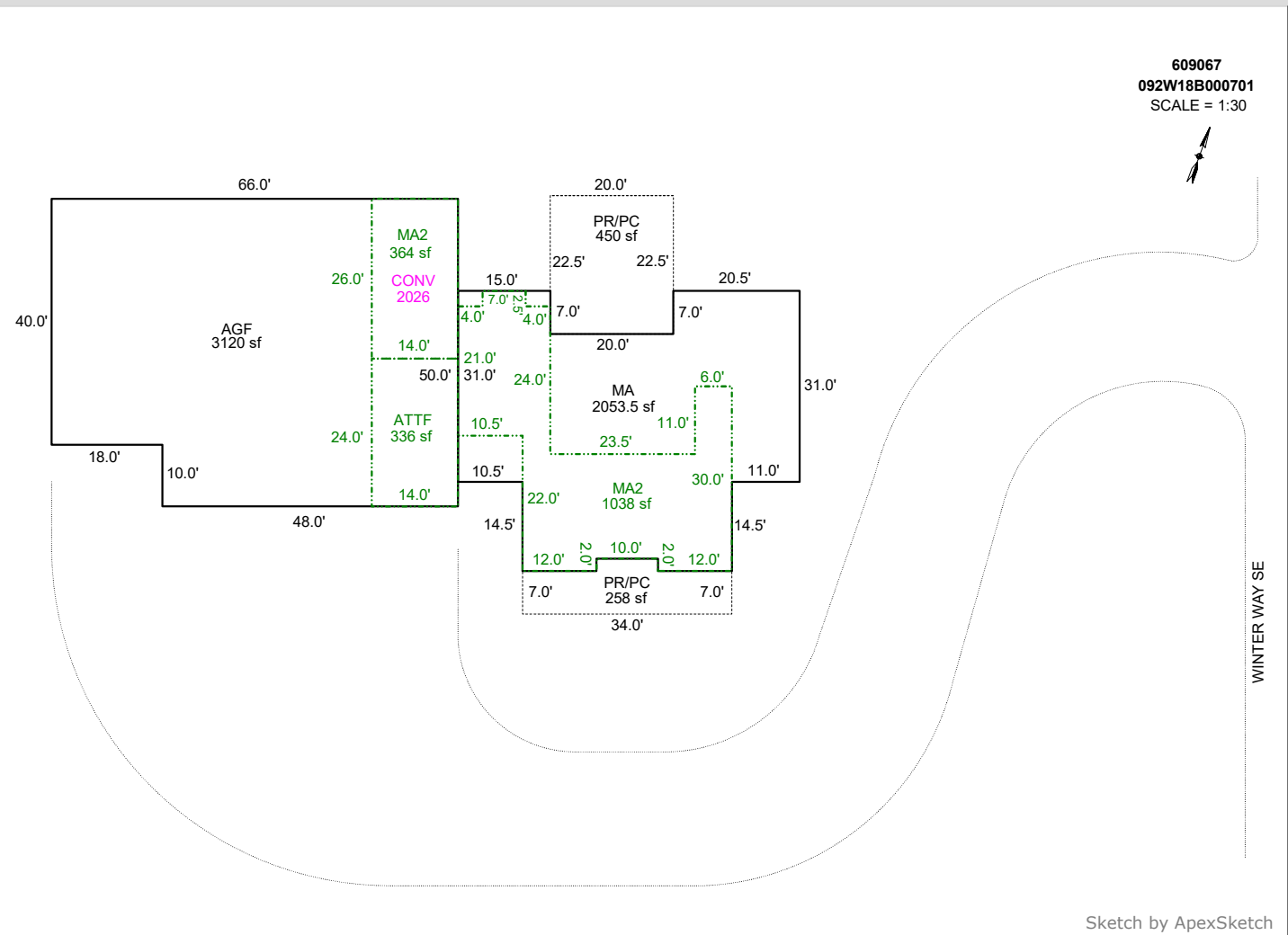

AREA CALCULATIONS SUMMARY						COMMENT TABLE 1	
Code	Description	Factor	Net Size	Perimeter	Net Totals		
GLA1	MA	1.0	2053.5	220.0	2053.5	APEX BY CJURAN 04/09/2024 24-000618 MA UPDATED BY CLOBERG 02/27/26 24-000618 REV	
GLA2	MA2	1.0	1038.0	206.0	1038.0		
GAR	AGF	1.0	3120.0	232.0			
	ATTF	1.0	336.0	76.0			
	MA2	1.0	364.0	80.0	3820.0		
P/P	PR/PC	1.0	258.0	86.0			
	PR/PC	1.0	450.0	85.0	708.0		
						COMMENT TABLE 2	COMMENT TABLE 3
Net LIVABLE		cnt	3 (rounded)		6,912		