

SKETCH/AREA TABLE ADDENDUM

SUBJECT INFO

File No.: 131625 Parcel No.: 062W31D000500
 Property Address: 5422 PORTLAND RD NE #53
 City: SALEM County: State: OR ZipCode: 97305
 Owner:
 Client: Client Address:
 Appraiser Name: Inspection Date:

SKETCH

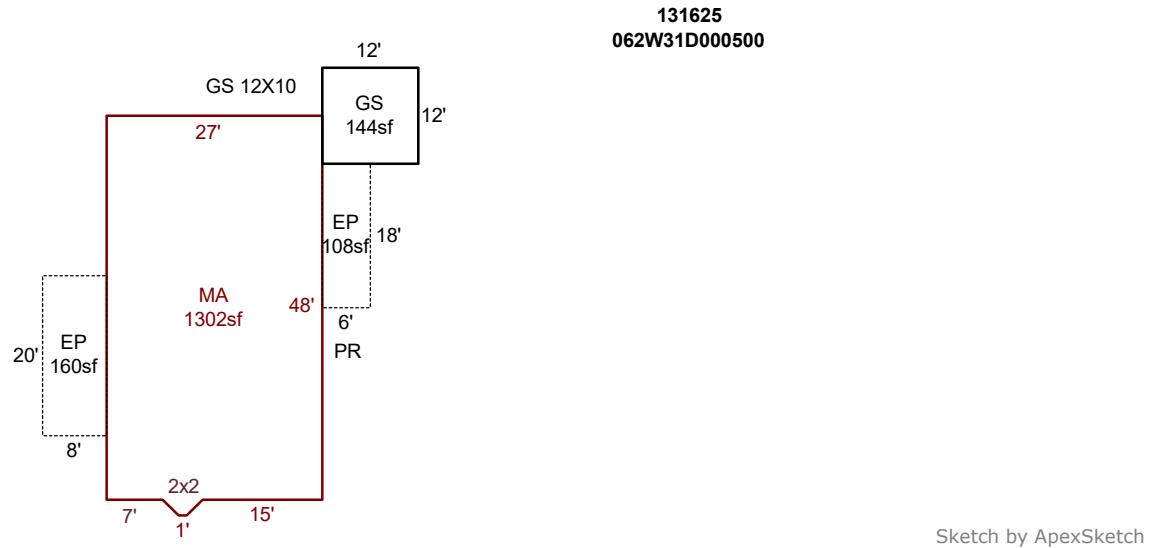

AREA CALCULATIONS SUMMARY

Code	Description	Factor	Net Size	Perimeter	Net Totals
GBA	GS	1.0	144.0	48.0	144.0
MFH	MA	1.0	1302.0	151.7	1302.0
P/P	EP	1.0	160.0	56.0	
	EP	1.0	108.0	48.0	268.0

COMMENT TABLE 1

DRAWN BY LK 3.16.26

COMMENT TABLE 2

6.12.25 CYCLE TS

COMMENT TABLE 3

Net LIVABLE	cnt	1	(rounded)	1,302
Net BUILDING	cnt	1	(rounded)	144