

2.4.26

Acct ID: 514794 MTL: 052W140001300 Date: 12/16/25 Appr: GRH Prop Class: 551 RMV Prop Class: 501  
 Situs: 14905 BUTTEVILLE RD NE GERVAIS OR 97026 MaSaNh: 02 06 000 Unit: 94713 Year: 2025

Last Date Appraised: 01/15/2025 Appraiser: JORDAN SCHULTZ Tag: Y N Tag info: 2026 - NEW CONSTRUCTION (Outbuilding)  
 Owner: WEISZ FAMILY LLC Last Sales Date: 01/28/2000 Roll Type: R  
 Cycle Tag Sales Verification Other: \_\_\_\_\_ Inspection level: 1 2 3 4 LCB TTO INSP AV: 898994  
 RMV Land: 2088210 RMV Imp: 503550 RMV Total: 2591760 MAV: 521330 MSAV: 395444 SAV: 1061894  
 Comment: 25-26: L3 1.15.25

Notations

RP/MS	Code	Description
RP	ZONED	FARM EFU ZONED

*Add mc, LTH, update inv*

*F*  
*24-007378*  
*101x75*  
*Agex*

OSDs

Count	Code	Description	RMV	Code Area	Exception
2	SAA	SA OSD - AVERAGE	50000	03600	0

*CWO 3/10/26*

*Farm o/c seed.*

Land

Site: 2 Code Area: 03600 Size: 1.00 Acres Use Code: 005 Zone: REST SAV Use: 011 Exception: 0  
 Class: 2BD Value Source: Farm Homesite Description: TWO BENCH DRY RMV: 8830 Exception: Y N  
 Adjustment(s): GSOIL, IRR Fire Patrol: Description:  
 Comments: Liability year - 2009

25-26: Updated land classes

Site: 3 Code Area: 03600 Size: 112.64 Acres Use Code: 005 Zone: REST SAV Use: 011 Exception: 0  
 Class: 2BI Value Source: Farm Use - EFU Description: TWO BENCH IRR RMV: 1039530 Exception: Y N  
 Adjustment(s): GSOIL, IRR Fire Patrol: Description:  
 Comments: Liability year - 1974 / 10300030

Site: 4 Code Area: 03600 Size: 34.92 Acres Use Code: 005 Zone: REST SAV Use: 011 Exception: 0  
 Class: 4BI Value Source: Farm Use - EFU Description: FOUR BENCH IRR RMV: 294240 Exception: Y N  
 Adjustment(s): GSOIL, IRR Fire Patrol: Description:  
 Comments: Liability year - 1974 / 10300030

Site: 5 Code Area: 01600 Size: 50.00 Acres Use Code: 005 Zone: REST SAV Use: 011 Exception: 0  
 Class: 2BI Value Source: Farm Use - EFU Description: TWO BENCH IRR RMV: 461440 Exception: Y N  
 Adjustment(s): GSOIL, IRR Fire Patrol: Description:  
 Comments: Liability year - 1974

Site: 6 Code Area: 01600 Size: 24.27 Acres Use Code: 005 Zone: REST SAV Use: 011 Exception: 0  
 Class: 4BI Value Source: Farm Use - EFU Description: FOUR BENCH IRR RMV: 204510 Exception: Y N  
 Adjustment(s): GSOIL, IRR Fire Patrol: Description:  
 Comments: Liability year - 1974 / 100030

Site: 7 Code Area: 03600 Size: 3.36 Acres Use Code: 005 Zone: REST SAV Use: 011 Exception: 0  
 Class: 2BD Value Source: Farm Use - EFU Description: TWO BENCH DRY RMV: 29660 Exception: Y N  
 Adjustment(s): GSOIL, IRR Fire Patrol: Description:  
 Comments: Liability year - 1974 / 10300030

Improvements - Residence / Manufactured Structures

Bldg: 1 Code Area: 03600 Stat Class: 132 + Year Blt: 1901 Eff Year Blt: 1901 Sq.Ft: 2884 % Complete: 100.00  
 Desc: Multi Story above grade Dimensions: RMV: 198900  
 Func Obsc: 100 Econ %: 100 Other %: 100 Exception: 0 Adjust: Adjust RMV: 0

Floors

Type	Class	Display Group	Floor Size	Beds	Baths	Yr Blt	Eff Yr Blt	Inventory	Exception
First Floor	3 +	Finished	1932	2	FB-2	1901	1901	BATH - 2, KIT-, HVAC, FP - 1, ROOF	Y N
Attic	3 +	Finished	952	0	0	1901	1901	HVAC	Y N
Garage Detached	3	Unfinished	936	0	0	1930	1930	ROOF <i>move to own stat</i>	Y N

Accessories

Description	Class	Size SqFt	Eff Yr Blt	RMV	Quantity	Exception
PATIO <i>413F</i>	3	3000	1901	6600	1	Y N

Bldg: 5 Code Area: 03600 Stat Class: 108 Year Blt: 1901 Eff Year Blt: 1901 Sq.Ft: 0 % Complete: 100.00  
 Desc: Residential Other Improvements Dimensions: RMV: 5720  
 Func Obsc: 100 Econ %: 100 Other %: 100 Exception: 0 Adjust: Adjust RMV: 0

Floors

Type	Class	Display Group	Floor Size	Beds	Baths	Yr Blt	Eff Yr Blt	Inventory
No floor data available								
<b>Accessories</b>								
Description	Class	Size SqFt	Eff Yr Blt	RMV	Quantity			
ASPHALT DRIVEWAY	1	4500	1901	5400	1	Exception: Y N		

**Improvements - Accessory Buildings**

Bldg: 2 Code Area: 03600 Stat Class: 351 Year Blt: 1964 Eff Year Blt: 1964 Sq.Ft: 3200 % Complete: 100.00  
 Desc: General Purpose Building (GB) Dimensions: 100x32 RMV: 12580  
 Func Obsc: 100 Econ %: 100 Other %: 100 Exception: 0 Adjust: Adjust RMV: 0

**Floors**

Type	Class	Display Group	Floor Size	Beds	Baths	Yr Blt	Eff Yr Blt	Inventory
General Purpose Bldg	5	Finished	3200	0	0	1964	1964	FAIR
Exception: Y N								

**Accessories**

Description	Class	Size SqFt	Eff Yr Blt	RMV	Quantity
No accessory data available					

Bldg: 3 Code Area: 03600 Stat Class: 312 Year Blt: 1964 Eff Year Blt: 1964 Sq.Ft: 5000 % Complete: 100.00  
 Desc: Loft Barn (LB) Dimensions: 100x50 RMV: 35780  
 Func Obsc: 100 Econ %: 100 Other %: 100 Exception: 0 Adjust: Adjust RMV: 0

**Floors**

Type	Class	Display Group	Floor Size	Beds	Baths	Yr Blt	Eff Yr Blt	Inventory
Loft Barn	6	Finished	5000	0	0	1964	1964	FAIR
Exception: Y N								

**Accessories**

Description	Class	Size SqFt	Eff Yr Blt	RMV	Quantity
No accessory data available					

Bldg: 4 Code Area: 03600 Stat Class: 351 Year Blt: 1982 Eff Year Blt: 1982 Sq.Ft: 1300 % Complete: 100.00  
 Desc: General Purpose Building (GB) Dimensions: 50x26 RMV: 5610  
 Func Obsc: 100 Econ %: 100 Other %: 100 Exception: 0 Adjust: Adjust RMV: 0

**Floors**

Type	Class	Display Group	Floor Size	Beds	Baths	Yr Blt	Eff Yr Blt	Inventory
General Purpose Bldg	5	Finished	1300	0	0	1982	1982	FAIR
Exception: Y N								

**Accessories**

Description	Class	Size SqFt	Eff Yr Blt	RMV	Quantity
No accessory data available					

Bldg: 6 Code Area: 03600 Stat Class: 301 Year Blt: Eff Year Blt: Sq.Ft: 288 % Complete: 100.00  
 Desc: Accessory Improvements & Misc. Dimensions: 24x12 RMV: 0  
 Func Obsc: 100 Econ %: 100 Other %: 100 Exception: 0 Adjust: Adjust RMV: 0

**Floors**

Type	Class	Display Group	Floor Size	Beds	Baths	Yr Blt	Eff Yr Blt	Inventory
Pump House	0	Finished	288	0	0	0	0	Finished
Exception: Y N								

**Accessories**

Description	Class	Size SqFt	Eff Yr Blt	RMV	Quantity
No accessory data available					

Bldg: 7 Code Area: 03600 Stat Class: 331 Year Blt: Eff Year Blt: Sq.Ft: 336 % Complete: 100.00  
 Desc: Milking Parlor (MK) Dimensions: 24x14 RMV: 0  
 Func Obsc: 0 Econ %: 100 Other %: 100 Exception: 0 Adjust: Adjust RMV: 0

**Floors**

Type	Class	Display Group	Floor Size	Beds	Baths	Yr Blt	Eff Yr Blt	Inventory
Milking Parlor	4	Finished	336	0	0	0	0	Finished
Exception: Y N								

**Accessories**

Description	Class	Size SqFt	Eff Yr Blt	RMV	Quantity
No accessory data available					

Bldg: 8 Code Area: 03600 Stat Class: 341 Year Blt: Eff Year Blt: Sq.Ft: 144 % Complete: 100.00  
 Desc: Multi Purpose Shed (MP) Dimensions: 12x12 RMV: 3620  
 Func Obsc: 100 Econ %: 100 Other %: 100 Exception: 0 Adjust: Adjust RMV: 0

**Floors**

Type	Class	Display Group	Floor Size	Beds	Baths	Yr Blt	Eff Yr Blt	Inventory
Multi-Purpose Bldg	4	Finished	144	0	0	0	0	FAIR

Exception: Y N

**Accessories**

Description	Class	Size SqFt	Eff Yr Blt	RMV	Quantity
No accessory data available					

Bldg: 9 Code Area: 03600 Stat Class: 325 Year Blt: Eff Year Blt: Sq.Ft: 0 % Complete: 100.00  
 Desc: Commercial Grain Storage (GR) Dimensions: RMV: 0  
 Func Obsc: 100 Econ %: 100 Other %: 100 Exception: 0 Adjust: Adjust RMV: 0

**Floors**

Type	Class	Display Group	Floor Size	Beds	Baths	Yr Blt	Eff Yr Blt	Inventory
Grain Bin	4	Finished	0	0	0	0	0	Exception: Y N

**Accessories**

Description	Class	Size SqFt	Eff Yr Blt	RMV	Quantity
No accessory data available					

Bldg: 10 Code Area: 03600 Stat Class: 341 Year Blt: Eff Year Blt: Sq.Ft: 0 % Complete: 100.00  
 Desc: Multi Purpose Shed (MP) Dimensions: RMV: 0  
 Func Obsc: 100 Econ %: 100 Other %: 100 Exception: 0 Adjust: Adjust RMV: 0

**Floors**

Type	Class	Display Group	Floor Size	Beds	Baths	Yr Blt	Eff Yr Blt	Inventory
Multi-Purpose Bldg	4	Finished	0	0	0	0	0	Exception: Y N

**Accessories**

Description	Class	Size SqFt	Eff Yr Blt	RMV	Quantity
No accessory data available					

Bldg: 11 Code Area: 03600 Stat Class: 354 Year Blt: Eff Year Blt: 1974 Sq.Ft: 340 % Complete: 100.00  
 Desc: Lean-to Light (LTL) Dimensions: 20x17 RMV: 1380  
 Func Obsc: 100 Econ %: 100 Other %: 100 Exception: 0 Adjust: Adjust RMV: 0

**Floors**

Type	Class	Display Group	Floor Size	Beds	Baths	Yr Blt	Eff Yr Blt	Inventory
Lean-to Light Duty	4	Finished	340	0	0	0	0	Exception: Y N

**Accessories** change to mp 4 walls with door window I/O

Description	Class	Size SqFt	Eff Yr Blt	RMV	Quantity
No accessory data available					

Bldg: 12 Code Area: 03600 Stat Class: 354 Year Blt: Eff Year Blt: Sq.Ft: 144 % Complete: 100.00  
 Desc: Lean-to Light (LTL) Dimensions: 12x12 RMV: 580  
 Func Obsc: 100 Econ %: 100 Other %: 100 Exception: 0 Adjust: Adjust RMV: 0

**Floors**

Type	Class	Display Group	Floor Size	Beds	Baths	Yr Blt	Eff Yr Blt	Inventory
Lean-to Light Duty	4	Finished	144	0	0	0	0	Exception: Y N

**Accessories**

Description	Class	Size SqFt	Eff Yr Blt	RMV	Quantity
No accessory data available					

Bldg: 13 Code Area: 03600 Stat Class: 342 Year Blt: 1989 Eff Year Blt: 1989 Sq.Ft: 23400 % Complete: 100.00  
 Desc: Metal Component Building (MC) Dimensions: 234x100 RMV: 201100  
 Func Obsc: 100 Econ %: 100 Other %: 100 Exception: 0 Adjust: Adjust RMV: 0

**Floors**

Type	Class	Display Group	Floor Size	Beds	Baths	Yr Blt	Eff Yr Blt	Inventory
Metal Componet Bldg	5	Finished	23400	0	0	1989	1989	FAIR

**Accessories** Addn 9,400 new 40 good per calc n/c 46 est

Description	Class	Size SqFt	Eff Yr Blt	RMV	Quantity
No accessory data available					

Bldg: 14 Code Area: 03600 Stat Class: 305 Year Blt: Eff Year Blt: Sq.Ft: 0 % Complete: 100.00  
 Desc: Tank/Silo/Bin Dimensions: RMV: 2500  
 Func Obsc: 100 Econ %: 100 Other %: 100 Exception: 0 Adjust: Adjust RMV: 0

**Floors**

510 upright

Type	Class	Display Group	Floor Size	Beds	Baths	Yr Blt	Eff Yr Blt	Inventory
No floor data available								
<b>Accessories</b>								
Description	Class	Size SqFt	Eff Yr Blt	RMV	Quantity			
No accessory data available								

Bldg: 15 Code Area: 03600 Stat Class: 305 Year Blt: Eff Year Blt: Sq.Ft: 0 % Complete: 100.00  
 Desc: Tank/Silo/Bin Dimensions: RMV: 2000 ✓  
 Func Obsc: 100 Econ %: 100 Other %: 100 Exception: 0 Adjust: Adjust RMV: 0

Type	Class	Display Group	Floor Size	Beds	Baths	Yr Blt	Eff Yr Blt	Inventory
No floor data available								

Gas pumps

Description	Class	Size SqFt	Eff Yr Blt	RMV	Quantity			
No accessory data available								

Bldg: 16 Code Area: 03600 Stat Class: 352 Year Blt: 1992 Eff Year Blt: 1992 Sq.Ft: 4000 % Complete: 100.00  
 Desc: Utility Building (UB) Dimensions: 100x40 RMV: 26560 ✓  
 Func Obsc: 100 Econ %: 100 Other %: 100 Exception: 0 Adjust: Adjust RMV: 0

Type	Class	Display Group	Floor Size	Beds	Baths	Yr Blt	Eff Yr Blt	Inventory
Utility Building	5	Finished	4000	0	0	1992	1992	FAIR
Exception: Y N								

Description	Class	Size SqFt	Eff Yr Blt	RMV	Quantity			
No accessory data available								

Bldg: 17 Code Area: 03600 Stat Class: 311 Year Blt: 1974 Eff Year Blt: 1974 Sq.Ft: 3840 % Complete: 100.00  
 Desc: Feeder Barn (FB) Dimensions: 64x60 RMV: 7220 ✓  
 Func Obsc: 100 Econ %: 100 Other %: 100 Exception: 0 Adjust: Adjust RMV: 0

Type	Class	Display Group	Floor Size	Beds	Baths	Yr Blt	Eff Yr Blt	Inventory
Feeder Barn	4	Finished	3840	0	0	1974	1974	FAIR
Exception: Y N								

Description	Class	Size SqFt	Eff Yr Blt	RMV	Quantity			
No accessory data available								

**Farm Notes**

2025FARM

3/11/25: Inspected by WW L4 during tags, farm use ok - grass seed

~~LTH 15x75 2024 New~~  
 MC 80x40 1982 1/0 in 95 photos  
 MP 16x16 1992 1/0 in 09 photos  
 GB 56x54 2018 Avg New



12.16.25



12.16.25

ACCESSORY IMPROVEMENTS		OUTBUILDINGS	
TYPE	<u>mc</u>	TYPE	<u>LTE</u>
STAT / CLASS	<u>5</u>	STAT / CLASS	
SIZE		SIZE	<u>15x75</u>
FAIR	<del>X</del> <u>100</u>	FAIR	
AVERAGE	<u>94</u>	AVERAGE	
<u>GOOD</u>		GOOD	
EXCELLENT		EXCELLENT	
BATH		BATH	
YR BLT	<u>2025</u>	YR BLT	<u>2025</u>
EFF YR	<u>2025</u>	EFF YR	<u>2025</u>
% COMP	<u>100</u>	% COMP	<u>100</u>
EXCEPT	<u>Y</u> N	EXCEPT	<u>Ø</u> N
MISC:		MISC:	
COMMENT:		COMMENT:	

# SKETCH/AREA TABLE ADDENDUM

## SUBJECT INFO

File No.: 514794 Parcel No.: 052W14 01300  
 Property Address: 14905 BUTTEVILLE RD NE  
 City: GERVAIS County: State: OR ZipCode: 97026  
 Owner:  
 Client: Client Address:  
 Appraiser Name: Inspection Date:

## SKETCH

**514794**

**052W14 01300**

\*SEE PAGE TWO FOR HOME DIMENSIONS\*  
 SCALE=1:115

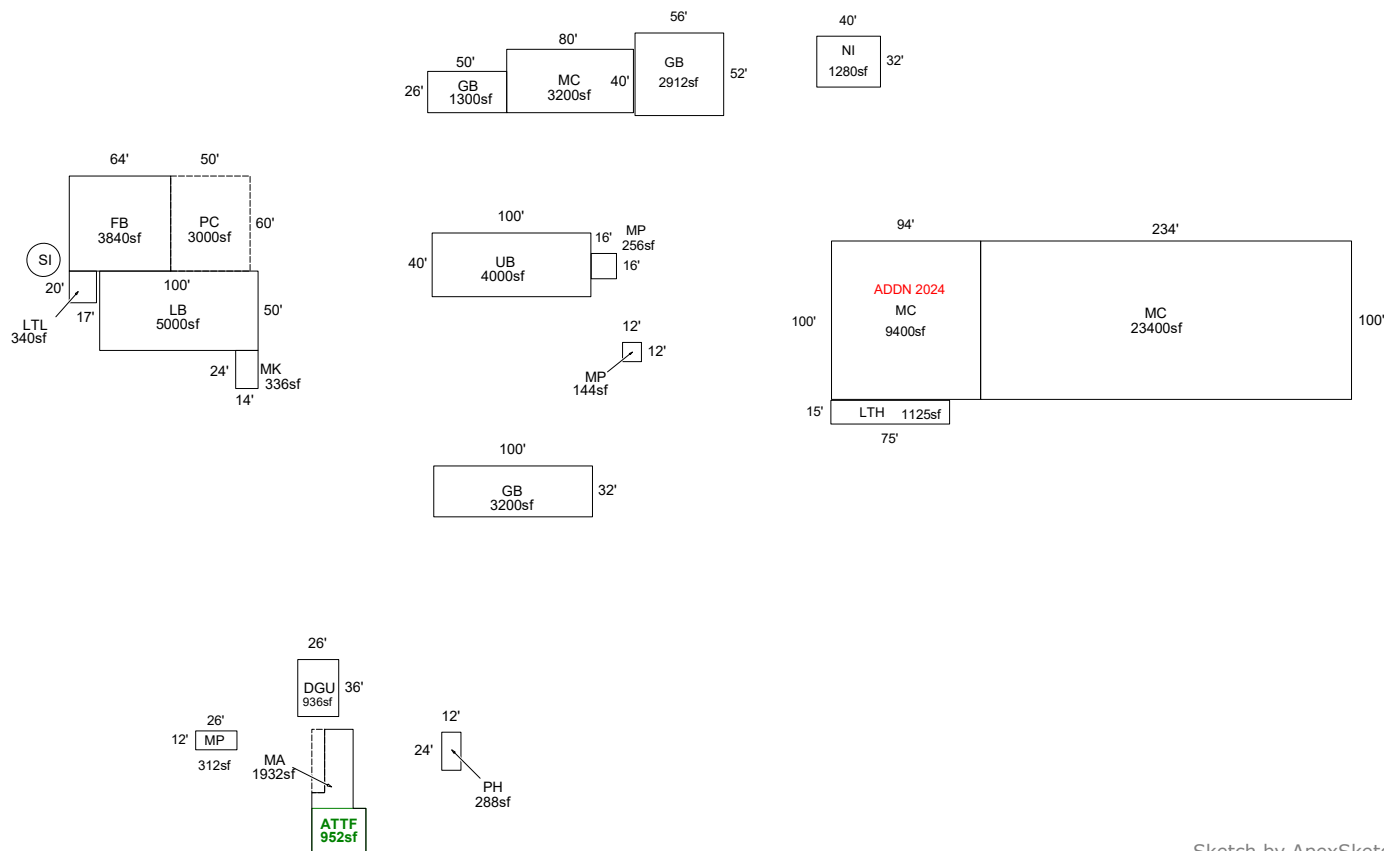

Sketch by ApexSketch

AREA CALCULATIONS SUMMARY						COMMENT TABLE 1					
Code	Description	Factor	Net Size	Perimeter	Net Totals						
GBA1	GB	1.0	1300.0	152.0	48272.0	APEXED BY NRC 05/13/2009 UPDATED BY WWILLIAMS 10/16/25 UPDATED BY CLOBERG 03/12/26					
	GB	1.0	2912.0	216.0							
	MC	1.0	23400.0	668.0							
	GB	1.0	3200.0	264.0							
	UB	1.0	4000.0	280.0							
	LB	1.0	5000.0	300.0							
	FB	1.0	3840.0	248.0							
	MK	1.0	336.0	76.0							
	LTL	1.0	340.0	74.0							
	MP	1.0	312.0	76.0							
	MC	1.0	3200.0	240.0							
	MP	1.0	144.0	48.0							
	PH	1.0	288.0	72.0							
	MA	1.0	1932.0	193.2							
GBA3	MP	1.0	256.0	64.0	256.0	<table border="1" style="width: 100%; border-collapse: collapse;"> <tr style="background-color: #cccccc;"> <th style="width: 50%;">COMMENT TABLE 2</th> <th style="width: 50%;">COMMENT TABLE 3</th> </tr> <tr> <td>GRH 12/16/25</td> <td>TAGS L3</td> </tr> </table>		COMMENT TABLE 2	COMMENT TABLE 3	GRH 12/16/25	TAGS L3
COMMENT TABLE 2	COMMENT TABLE 3										
GRH 12/16/25	TAGS L3										
GBA6	LTH	1.0	1125.0	180.0							
	MC	1.0	9400.0	388.0							
	6 addl items										
	Net LIVABLE	cnt	1	(rounded)	3,820						
	Net BUILDING	cnt	0	(rounded)	60,333						

# SKETCH/AREA TABLE ADDENDUM

## SUBJECT INFO

File No.: 514794 Parcel No.: 052W14 01300  
 Property Address: 14905 BUTTEVILLE RD NE  
 City: GERVAIS County: State: OR ZipCode: 97026  
 Owner:  
 Client: Client Address:  
 Appraiser Name: Inspection Date:

## SKETCH

**052W14 01300**  
**514794**  
 "SEE PAGE ONE FOR ALL BUILDINGS"

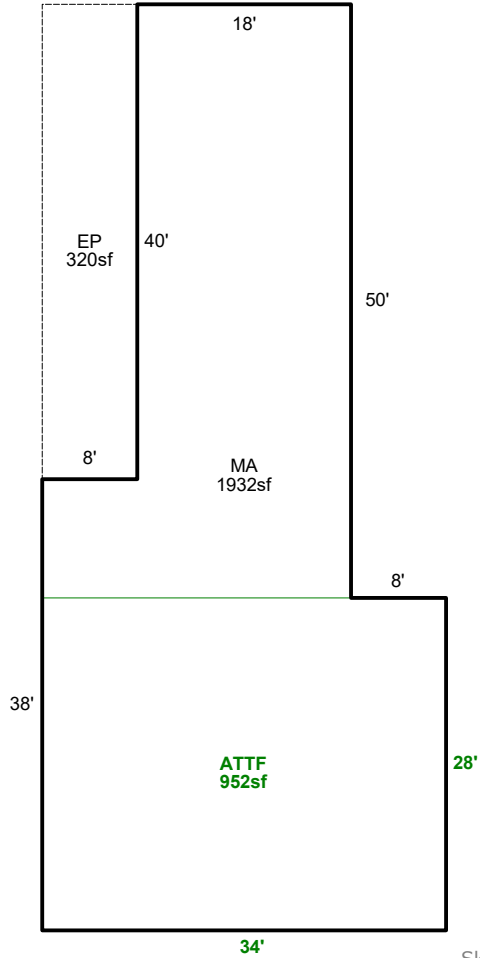

Sketch by ApexSketch

### AREA CALCULATIONS SUMMARY

Code	Description	Factor	Net Size	Perimeter	Net Totals
GLA1	MA	1.0	1932.0	224.0	1932.0
GLA2	ATTF	1.0	952.0	124.0	952.0
P/P	EP	1.0	320.0	96.0	320.0

### COMMENT TABLE 1

APEXED BY NRC 05/13/2009  
 UPDATED BY WILLIAMS 10/16/25  
 UPDATED BY CLOBERG 03/12/26

### COMMENT TABLE 2

GRH 12/16/25

### COMMENT TABLE 3

TAGS L3

Net LIVABLE                      cnt                      0      (rounded)                      2,884

# SKETCH/AREA TABLE ADDENDUM

## SUBJECT INFO

File No.: 514794 Parcel No.: 052W14 01300  
 Property Address: 14905 BUTTEVILLE RD NE  
 City: GERVAIS County: State: OR ZipCode: 97026  
 Owner:  
 Client: Client Address:  
 Appraiser Name: Inspection Date:

## SKETCH

**052W14 01300**  
**514794**

"SEE PAGE TWO FOR HOME DIMENSIONS"  
 SCALE=1:115

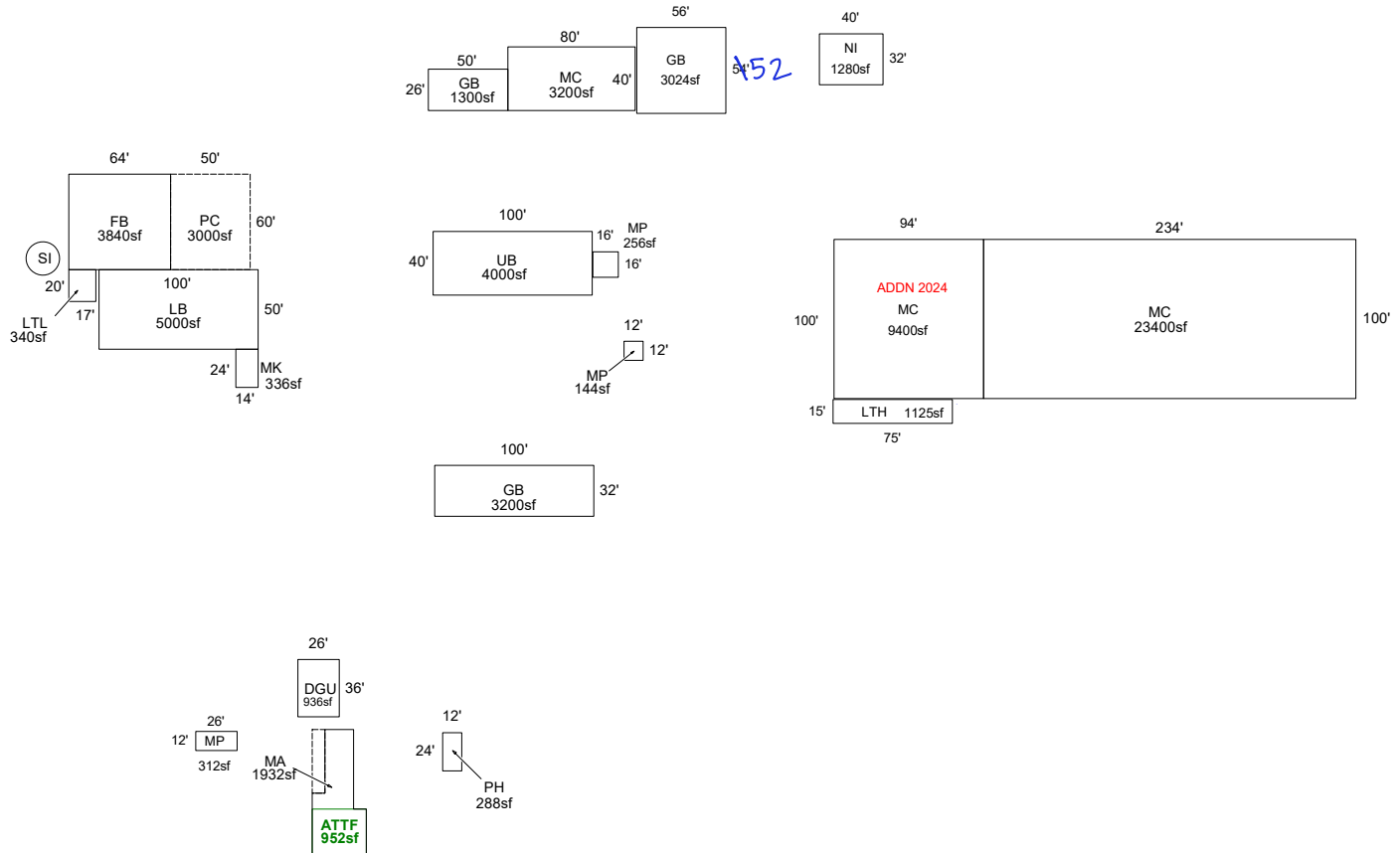

Sketch by ApexSketch

### AREA CALCULATIONS SUMMARY

Code	Description	Factor	Net Size	Perimeter	Net Totals
GBA1	GB	1.0	1300.0	152.0	
	GB	1.0	3024.0	220.0	
	MC	1.0	23400.0	668.0	
	GB	1.0	3200.0	264.0	
	UB	1.0	4000.0	280.0	
	LB	1.0	5000.0	300.0	
	FB	1.0	3840.0	248.0	
	MK	1.0	336.0	76.0	
	LTL	1.0	340.0	74.0	
	MP	1.0	312.0	76.0	
	MC	1.0	3200.0	240.0	
	MP	1.0	144.0	48.0	
	PH	1.0	288.0	72.0	48384.0
	GBA3	MP	1.0	256.0	64.0
GBA6	LTH	1.0	1125.0	180.0	
	MC	1.0	9400.0	388.0	
	6 addl items				
	Net LIVABLE	cnt	2 (rounded)		2,884
	Net BUILDING	cnt	17 (rounded)		60,445

### COMMENT TABLE 1

APEXED BY NRC 05/13/2009  
 UPDATED BY WWILLIAMS 10/16/25

### COMMENT TABLE 2

GPH 12/16/25

### COMMENT TABLE 3

TAGS L3

# SKETCH/AREA TABLE ADDENDUM

## SUBJECT INFO

File No.: 514794 Parcel No.: 052W14 01300  
 Property Address: 14905 BUTTEVILLE RD NE  
 City: GERVAIS County: State: OR ZipCode: 97026  
 Owner:  
 Client: Client Address:  
 Appraiser Name: Inspection Date:

## SKETCH

**052W14 01300**  
**514794**  
 "SEE PAGE ONE FOR ALL BUILDINGS"

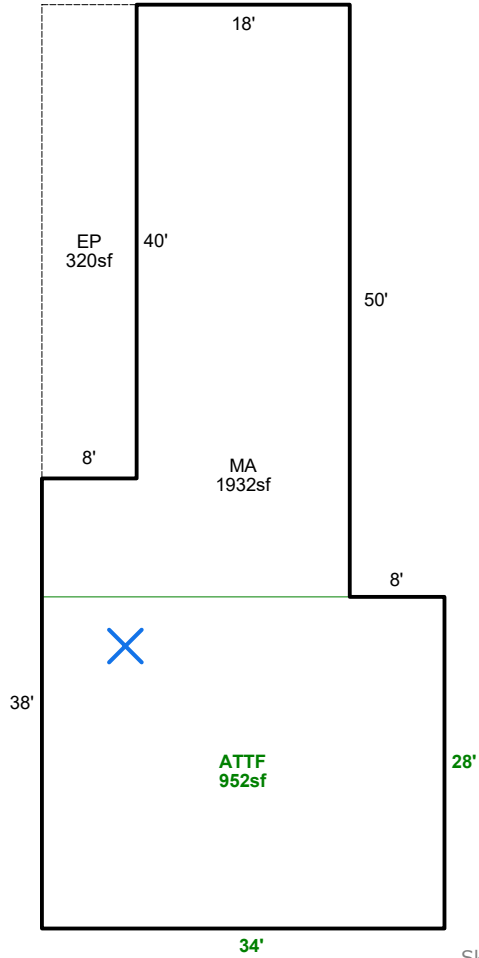

Sketch by ApexSketch

### AREA CALCULATIONS SUMMARY

Code	Description	Factor	Net Size	Perimeter	Net Totals
GLA1	MA	1.0	1932.0	224.0	1932.0
GLA2	ATTF	1.0	952.0	124.0	952.0
P/P	EP	1.0	320.0	96.0	320.0

### COMMENT TABLE 1

APEXED BY NRC 05/13/2009  
 UPDATED BY WWILLIAMS 10/16/25

### COMMENT TABLE 2

### COMMENT TABLE 3

Net LIVABLE                      cnt                      2                      (rounded)                      2,884

# Assessor Monthly Issued Permit Report

For 10/1/2024 to 10/31/2024

PERMIT#: 555-24-007378-AGE STATUS: Approved  
 PERMIT TYPE: Commercial APPLIED: 9/17/2024  
 SUB-TYPE: Agricultural Equine APPROVED: 10/10/2024  
 CATEGORY: Exemption Info EXPIRES:

OFFICE: MC  
 PARCEL#: 052W140001300 R14794  
 ACRES: 151.92  
 SUBDIV:  
 LOT/BLOCK: /  
 ADDRESS: 14905 BUTTEVILLE RD NE GERVAIS, OR 97026

RELATIONSHIP	NAME	ADDRESS	PHONE
APPLICANT	WEISZ FAMILY LLC	14905 BUTTEVILLE RD NE GERVAIS, OR 97026	503-792-4760
OWNER	WEISZ FAMILY LLC	14905 BUTTEVILLE RD NE GERVAIS, OR 97026	

CONST CAT:

WORK TYPE:

WORK DESC: 101x75 AGEX NO PLUM

VALUATION: \$0.00

STORIES:

BATHS:

KITCHENS:

SQUARE FEET

HABITABLE:

EXISTING:

NEW:

**TOTAL SQ. FT.:**