

Acct ID: 339767 MTL: 083W27A000101 Date: 1/6/26 Appr: GRH Prop Class: 401 RMV Prop Class: 401
 Situs: 6998 CHAKARUN LN SE SALEM OR 97306 MaSaNh: 06 06 000 Unit: 95302 Year: 2026

Last Date Appraised: 03/10/2017 Appraiser: GERARDO RAMIREZ HERNANDEZ Tag: Y N Tag info:

Owner: STEVEN A WARD TR & WARD, STEVEN A TRE Last Sales Date: 04/16/2012 Roll Type: R
 Cycle: Tag Sales Verification Other: _____ Inspection level: 1 2 3 4 LCB TTG INSP AV: 721200
 RMV Land: 321420 RMV Imp: 898380 RMV Total: 1219800 MAV: 721200 MSAV: 0 SAV: 0
 Comment:

Solar 100%

OSDs

Count	Code	Description	RMV	Code Area	Exception
1	MKTG	OSD - GOOD	65000	92430	0

Land

Site: 1 Code Area: 92430 Size: 2.48 Acres Use Code: 004 Zone: NREST SAV Use: Exception: 0
 Class: Value Source: Rural at MKT Description: RMV: 256420 Exception: Y N
 Adjustment(s): VWAR Fire Patrol: Description:
 Comments: 15-16: PER #73 ADD OSD FOR NEW RES AND VIEW ADJ// 01-02; REAPPRAISAL //F06-590 SEPE FROM R61418 TO R339767 , ALL IMPS STAY ON R61418

Improvements - Residence / Manufactured Structures

Bldg: 1 Code Area: 92430 Stat Class: 153 Year Blt: 2014 Eff Year Blt: 2014 Sq.Ft: 4153 % Complete: 100.00
 Desc: One Story with basement Dimensions: RMV: 827890
 Func Obsc: 100 Econ %: 100 Other %: 100 Exception: 0 Adjust: Adjust RMV: 0

Floors

Type	Class	Display Group	Floor Size	Beds	Baths	Yr Blt	Eff Yr Blt	Inventory	Exception
First Floor	5	Finished	2284	1	FB-2	2014	2014	FP - 1, BATH - 2, KIT+, HVAC+, ROOF	Y N
Basement	5	Finished	1869	3	FB-1	2014	2014	HVAC+, BATH - 1, FP - 1	Y N
Garage Attached	5	Finished	1027	0	0	2014	2014	ROOF	Y N
Garage Basement	5	Finished	415	0	0	2014	2014		Y N

Accessories

Description	Class	Size SqFt	Eff Yr Blt	RMV	Quantity	Exception
ASPHALT DRIVEWAY	5	3000	2015	8550	1	Y N
YARD IMPROVEMENTS GOOD	5	1	2014	44413	1	Y N

Bldg: 4 Code Area: 92430 Stat Class: 148 Year Blt: 2016 Eff Year Blt: 2016 Sq.Ft: 0 % Complete: 100.00
 Desc: Res other improvements Dimensions: RMV: 55490
 Func Obsc: 100 Econ %: 100 Other %: 100 Exception: 0 Adjust: Adjust RMV: 0

Floors

Type	Class	Display Group	Floor Size	Beds	Baths	Yr Blt	Eff Yr Blt	Inventory	Exception
Garage Detached	4	Finished	616	0	0	2016	2016	ROOF	Y N

Accessories

Description	Class	Size SqFt	Eff Yr Blt	RMV	Quantity
No accessory data available					

Improvements - Accessory Buildings

Bldg: 3 Code Area: 92430 Stat Class: 905 Year Blt: 2015 Eff Year Blt: 2015 Sq.Ft: 0 % Complete: 100.00
 Desc: Rural Solar Panel/Array Dimensions: RMV: 15000
 Func Obsc: 100 Econ %: 100 Other %: 100 Exception: 0 Adjust: Adjust RMV: 0

Floors

Type	Class	Display Group	Floor Size	Beds	Baths	Yr Blt	Eff Yr Blt	Inventory
No floor data available								

Accessories

Description	Class	Size SqFt	Eff Yr Blt	RMV	Quantity
No accessory data available					

Permits

ACCOUNT # 339767 DATE: _____ RMV CLASS _____ PROP CLASS _____
 MTL _____ APPR GZH TAG Y (N) _____
 COMMENTS: _____

RESIDENCE / MANUFACTURED STRUCTURES

ACCESSORY IMPROVEMENTS / OUTBUILDINGS

STAT _____ QLTY + - FLOOR _____
 AREA _____ EFF AREA _____ BED _____
 ROOF + HVAC +
 BATH PKG: _____ BATH _____ BATH + _____ 1/2 BTH
 FIREPLACE: _____
 KITCHEN - +
 YR BLT _____ EFF YR _____ ECON _____
 % COMP _____ % GOOD _____ FUNC _____
 EXCEPT Y N LUMP SUM: _____

MISC: _____
 YI CLASS _____ F G A E
 SKIRT + LIN FT _____
 COMMENT: _____

STAT _____ QLTY + - FLOOR _____
 AREA _____ EFF AREA _____ BED _____
 ROOF + HVAC +
 BATH PKG: _____ BATH _____ BATH + _____ 1/2 BTH
 FIREPLACE: _____
 KITCHEN - +
 YR BLT _____ EFF YR _____ ECON _____
 % COMP _____ % GOOD _____ FUNC _____
 EXCEPT Y N LUMP SUM: _____

MISC: _____
 YI CLASS _____ F G A E
 SKIRT + LIN FT _____
 COMMENT: _____

STAT _____ QLTY + - FLOOR _____
 AREA _____ EFF AREA _____ BED _____
 ROOF + HVAC +
 BATH PKG: _____ BATH _____ BATH + _____ 1/2 BTH
 FIREPLACE: _____
 KITCHEN - +
 YR BLT _____ EFF YR _____ ECON _____
 % COMP _____ % GOOD _____ FUNC _____
 EXCEPT Y N LUMP SUM: _____

MISC: _____
 YI CLASS _____ F G A E
 SKIRT + LIN FT _____
 COMMENT: _____

TYPE Solar
 STAT / CLASS _____
 SIZE 905
 FAIR
 AVERAGE 6,600
 GOOD
 EXCELLENT

BATH _____
 YR BLT 2025
 EFF YR _____
 % COMP 100
 EXCEPT Y N

MISC: _____
 COMMENT: _____

TYPE _____
 STAT / CLASS _____
 SIZE _____
 FAIR
 AVERAGE
 GOOD
 EXCELLENT

BATH _____
 YR BLT _____
 EFF YR _____
 % COMP _____
 EXCEPT Y N
 MISC: _____
 COMMENT: _____

TYPE _____
 STAT / CLASS _____
 SIZE _____
 FAIR
 AVERAGE
 GOOD
 EXCELLENT

BATH _____
 YR BLT _____
 EFF YR _____
 % COMP _____
 EXCEPT Y N

MISC: _____
 COMMENT: _____

TYPE _____
 STAT / CLASS _____
 SIZE _____
 FAIR
 AVERAGE
 GOOD
 EXCELLENT

BATH _____
 YR BLT _____
 EFF YR _____
 % COMP _____
 EXCEPT Y N
 MISC: _____
 COMMENT: _____

Permit Number	Permit ID	Origin	Category	Type	Estimate Value	% Complete	Roll Type	Description
25-007351	85453	MARION COUNTY	TAGS/PERMITS	ALT ENERGY SYSTEM	6663	0	R	SOLAR ARRAY 5.3KW ON ROOF @ \$6,663



SKETCH/AREA TABLE ADDENDUM

Parcel No 083W27A 00101

File No R339767

Property Address 6998 CHAKARUN LN SE

City SALEM

County MARION

State OR

Zip 97306

Owner

Client

Appraiser Name

SUBJECT

IMPROVEMENTS SKETCH

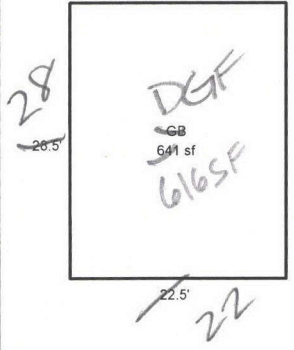
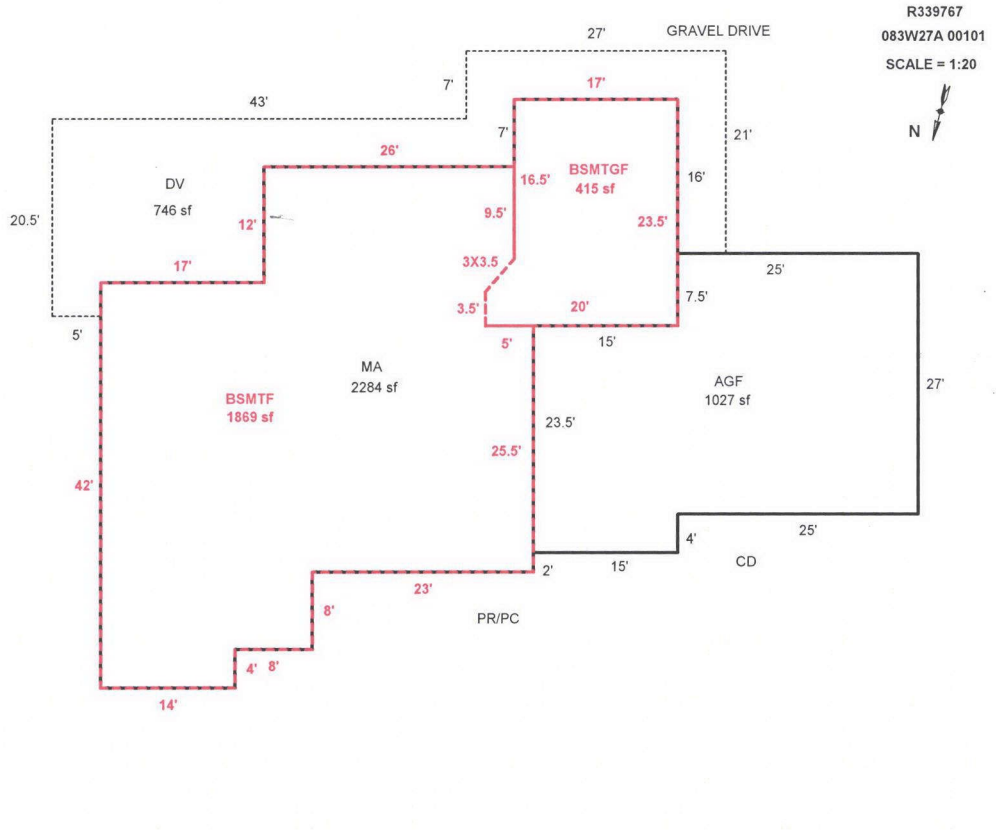

Scale: 1" = 20'

AREA CALCULATIONS

AREA CALCULATIONS SUMMARY

Code	Description	Factor	Net Size	Perimeter	Net Totals
GLA1	MA	1.00	2285	242	2285
GLA0	BSMTF	1.00	1869	202	1869
GBA1	GB	1.00	641	102	641
GAR	AGF	1.00	1028	142	1443
	BSMTGF	1.00	415	85	1443
P/P	DV	1.00	747	227	747

Net LIVABLE Area (rounded w/ factors) 4154
 Net BUILDING Area (rounded w/ factors) 641

Comment Table 1

DRAWN BY SRAGSDALE 6/9/14
 UPDATED BY JRONDEMA 5/20/15
 UPDATED BY JRONDEMA 5/4/16

Comment Table 2

Comment Table 3