

Acct ID: 515495 MTL: 061W020000100A1 Date: 8/28/25 Appr: MLH Prop Class: 501 ? RMV Prop Class: 501

Situs: 14358 DOMINIC RD NE MOUNT ANGEL OR 97362 MaSaNh: 02 06 000 Unit: 52816 Year: 2025

Last Date Appraised: 01/14/2015 Appraiser: JORDAN SCHULTZ Tag: Y N Tag info:  
 Owner: ANNEN BROS INC Last Sales Date: 03/30/1989 Roll Type: R  
 Cycle Tag Sales Verification Other: Clean UP Inspection level: 1 2 3 4 LCB TTO INSP AV: 376890  
 RMV Land: 0 RMV Imp: 568390 RMV Total: 568390 MAV: 376890 MSAV: 0 SAV: 0  
 Comment:

*update Inventory*

*Input MLH 8/28/25*

**Improvements - Residence / Manufactured Structures**

Bldg: 1 Code Area: 91470 Stat Class: 144 Year Blt: 1949 Eff Year Blt: 1980 Sq.Ft: 2360 % Complete: 100  
 Desc: Multi Story above grade with basement Dimensions: RMV: 430610  
 Func Obsc: 100 Econ %: 100 Other %: 100 Exception: 0 Adjust: Adjust RMV: 0

*N/C*

**Floors**

Type	Class	Display Group	Floor Size	Beds	Baths	Yr Blt	Eff Yr Blt	Inventory	Exception: Y N
First Floor	4	Finished	1488	1	FB-2	1949	1980	BATH - 2, KIT, ROOF, HVAC, FP - 1	Y N
Attic	4	Finished	872	3	FB-1	1949	1980	BATH - 1, HVAC	Y N
Basement	4	Unfinished	1488	0	0	1949	1980		Y N

**Accessories**

Description	Class	Size SqFt	Eff Yr Blt	RMV	Quantity	Exception: Y N
ENCLOSED PORCH	4	156	1980	4137	1	Y N
YARD IMPROVEMENTS GOOD	4	1	1980	33384	1	Y N

Bldg: 13 Code Area: 91470 Stat Class: 148 Year Blt: 1995 Eff Year Blt: 1995 Sq.Ft: 0 % Complete: 100  
 Desc: Res other improvements Dimensions: RMV: 76220  
 Func Obsc: 100 Econ %: 100 Other %: 100 Exception: 0 Adjust: Adjust RMV: 0

*I/O*

**Floors**

Type	Class	Display Group	Floor Size	Beds	Baths	Yr Blt	Eff Yr Blt	Inventory	Exception: Y N
Garage Oversized Detached	4	Low Cost	1056	0	0	1995	1995	ROOF	Y N

**Accessories**

Description	Class	Size SqFt	Eff Yr Blt	RMV	Quantity
No accessory data available					

**Improvements - Accessory Buildings**

Bldg: 2 Code Area: 91470 Stat Class: 341 Year Blt: 1974 Eff Year Blt: 1974 Sq.Ft: 120 % Complete: 100  
 Desc: Multi Purpose Shed (MP) Dimensions: 12x10 RMV: 1210  
 Func Obsc: 100 Econ %: 100 Other %: 100 Exception: 0 Adjust: Adjust RMV: 0

*N/C*

**Floors**

Type	Class	Display Group	Floor Size	Beds	Baths	Yr Blt	Eff Yr Blt	Inventory	Exception: Y N
Multi-Purpose Bldg	6	Finished	120	0	0	1974	1974	FAIR	Y N

**Accessories**

Description	Class	Size SqFt	Eff Yr Blt	RMV	Quantity
No accessory data available					

Bldg: 3 Code Area: 91470 Stat Class: 341 Year Blt: 1974 Eff Year Blt: 1974 Sq.Ft: 120 % Complete: 100  
 Desc: Multi Purpose Shed (MP) Dimensions: 12x10 RMV: 1210  
 Func Obsc: 100 Econ %: 100 Other %: 100 Exception: 0 Adjust: Adjust RMV: 0

*N/C*

**Floors**

Type	Class	Display Group	Floor Size	Beds	Baths	Yr Blt	Eff Yr Blt	Inventory	Exception: Y N
Multi-Purpose Bldg	6	Finished	120	0	0	1974	1974	FAIR	Y N

**Accessories**

Description	Class	Size SqFt	Eff Yr Blt	RMV	Quantity
No accessory data available					

Bldg: 4 Code Area: 91470 Stat Class: 313 Year Blt: 1989 Eff Year Blt: 1989 Sq.Ft: 2400 % Complete: 100  
 Desc: Free Stall Barn (SB) Dimensions: 60x40 RMV: 17540  
 Func Obsc: 100 Econ %: 100 Other %: 100 Exception: 0 Adjust: Adjust RMV: 0

*N/C*

Floors

Type	Class	Display Group	Floor Size	Beds	Baths	Yr Blt	Eff Yr Blt	Inventory	
Free Stall Barn	5	Finished	2400	0	0	1989	1989	AVG	Exception: Y N

Accessories

Description	Class	Size SqFt	Eff Yr Blt	RMV	Quantity
No accessory data available					

Bldg: 5 Code Area: 91470 Stat Class: 353 Year Blt: 1979 Eff Year Blt: 1979 Sq.Ft: 208 % Complete: 100  
 Desc: Machine Shed (MS) Dimensions: 16x13 RMV: 480  
 Func Obsc: 100 Econ %: 100 Other %: 100 Exception: 0 Adjust: Adjust RMV: 0

Floors

Type	Class	Display Group	Floor Size	Beds	Baths	Yr Blt	Eff Yr Blt	Inventory	
Machine Shed	4	Finished	208	0	0	1979	1979	Fair	Exception: Y N

Accessories

Description	Class	Size SqFt	Eff Yr Blt	RMV	Quantity
No accessory data available					

Bldg: 6 Code Area: 91470 Stat Class: 341 Year Blt: 1979 Eff Year Blt: 1979 Sq.Ft: 48 % Complete: 100  
 Desc: Multi Purpose Shed (MP) Dimensions: 8x6 RMV: 0  
 Func Obsc: 100 Econ %: 100 Other %: 100 Exception: 0 Adjust: Adjust RMV: 0

Floors

Type	Class	Display Group	Floor Size	Beds	Baths	Yr Blt	Eff Yr Blt	Inventory	
Multi-Purpose Bldg	4	Finished	48	0	0	1979	1979		Exception: Y N

Accessories

Description	Class	Size SqFt	Eff Yr Blt	RMV	Quantity
No accessory data available					

Bldg: 7 Code Area: 91470 Stat Class: 321 Year Blt: 1974 Eff Year Blt: 1974 Sq.Ft: 600 % Complete: 100  
 Desc: Hay Cover (HC) Dimensions: 50x12 RMV: 790  
 Func Obsc: 100 Econ %: 100 Other %: 100 Exception: 0 Adjust: Adjust RMV: 0

Floors

Type	Class	Display Group	Floor Size	Beds	Baths	Yr Blt	Eff Yr Blt	Inventory	
Hay Cover	4	Finished	600	0	0	1974	1974	Fair	Exception: Y N

Accessories

Description	Class	Size SqFt	Eff Yr Blt	RMV	Quantity
No accessory data available					

Bldg: 8 Code Area: 91470 Stat Class: 341 Year Blt: 1989 Eff Year Blt: 1989 Sq.Ft: 320 % Complete: 100  
 Desc: Multi Purpose Shed (MP) Dimensions: 20x16 RMV: 2310  
 Func Obsc: 100 Econ %: 100 Other %: 100 Exception: 0 Adjust: Adjust RMV: 0

Floors

Type	Class	Display Group	Floor Size	Beds	Baths	Yr Blt	Eff Yr Blt	Inventory	
Multi-Purpose Bldg	5	Finished	320	0	0	1989	1989	FAIR	Exception: Y N

Accessories

Description	Class	Size SqFt	Eff Yr Blt	RMV	Quantity
No accessory data available					

Bldg: 9 Code Area: 91470 Stat Class: 332 Year Blt: 2000 Eff Year Blt: 2000 Sq.Ft: 1920 % Complete: 100  
 Desc: Commercial Greenhouse (CG) Dimensions: 96x20 RMV: 3210  
 Func Obsc: 100 Econ %: 100 Other %: 100 Exception: 0 Adjust: Adjust RMV: 0

Floors

Type	Class	Display Group	Floor Size	Beds	Baths	Yr Blt	Eff Yr Blt	Inventory	
Commerical Greenhouse	4	Finished	1920	0	0	2000	2000		Exception: Y N

Accessories

Description	Class	Size SqFt	Eff Yr Blt	RMV	Quantity
No accessory data available					

Bldg: 10 Code Area: 91470 Stat Class: 341 Year Blt: 1950 Eff Year Blt: 1950 Sq.Ft: 70 % Complete: 100  
 Desc: Multi Purpose Shed (MP) Dimensions: 10x7 RMV: 60  
 Func Obsc: 100 Econ %: 100 Other %: 100 Exception: 0 Adjust: Adjust RMV: 0

Floors

Type	Class	Display Group	Floor Size	Beds	Baths	Yr Blt	Eff Yr Blt	Inventory	
Multi-Purpose Bldg	4	Finished	70	0	0	1950	1950	FAIR	Exception: Y N

**Accessories**

Description	Class	Size SqFt	Eff Yr Blt	RMV	Quantity
No accessory data available					

Bldg: 11	Code Area: 91470	Stat Class: 353	Year Blt: 2002	Eff Year Blt: 2002	Sq.Ft: 1200	% Complete: 100
Desc: Machine Shed (MS)			Dimensions: 60x20		RMV: 10330	
Func Obsc: 100	Econ %: 100	Other %: 100	Exception: 0	Adjust:	Adjust RMV: 0	N/C

**Floors**

Type	Class	Display Group	Floor Size	Beds	Baths	Yr Blt	Eff Yr Blt	Inventory	
Machine Shed	5	Finished	1200	0	0	2002	2002	FAIR	Exception: Y N

**Accessories**

Description	Class	Size SqFt	Eff Yr Blt	RMV	Quantity
No accessory data available					

Bldg: 12	Code Area: 91470	Stat Class: 351	Year Blt: 2003	Eff Year Blt: 2000	Sq.Ft: 1296	% Complete: 100
Desc: General Purpose Building (GB)			Dimensions: 36x36		RMV: 14530	
Func Obsc: 100	Econ %: 100	Other %: 100	Exception: 0	Adjust:	Adjust RMV: 0	N/C

**Floors**

Type	Class	Display Group	Floor Size	Beds	Baths	Yr Blt	Eff Yr Blt	Inventory	
General Purpose Bldg	5	Finished	1296	0	0	2003	2000	FAIR	Exception: Y N

**Accessories**

Description	Class	Size SqFt	Eff Yr Blt	RMV	Quantity
No accessory data available					

Bldg: 14	Code Area: 91470	Stat Class: 351	Year Blt: 2013	Eff Year Blt: 2013	Sq.Ft: 522	% Complete: 100
Desc: General Purpose Building (GB)			Dimensions: 29x18		RMV: 6620	
Func Obsc: 100	Econ %: 100	Other %: 100	Exception: 0	Adjust:	Adjust RMV: 0	I/O

**Floors**

Type	Class	Display Group	Floor Size	Beds	Baths	Yr Blt	Eff Yr Blt	Inventory	
General Purpose Bldg	4	Finished	522	0	0	2013	2013	FAIR	Exception: Y N

**Accessories**

Description	Class	Size SqFt	Eff Yr Blt	RMV	Quantity
No accessory data available					

Bldg: 15	Code Area: 91470	Stat Class: 332	Year Blt: 2000	Eff Year Blt: 2000	Sq.Ft: 1920	% Complete: 100
Desc: Commercial Greenhouse (CG)			Dimensions:		RMV: 3210	
Func Obsc: 100	Econ %: 100	Other %: 100	Exception: 0	Adjust:	Adjust RMV: 0	Gone

**Floors**

Type	Class	Display Group	Floor Size	Beds	Baths	Yr Blt	Eff Yr Blt	Inventory	
Commerical Greenhouse	4	Finished	1920	0	0	2000	2000		Exception: Y N

**Accessories**

Description	Class	Size SqFt	Eff Yr Blt	RMV	Quantity
No accessory data available					

Bldg: 16	Code Area: 91470	Stat Class: 341	Year Blt: 1950	Eff Year Blt: 1950	Sq.Ft: 70	% Complete: 100
Desc: Multi Purpose Shed (MP)			Dimensions:		RMV: 60	
Func Obsc: 100	Econ %: 100	Other %: 100	Exception: 0	Adjust:	Adjust RMV: 0	φ > 100 SF

**Floors**

Type	Class	Display Group	Floor Size	Beds	Baths	Yr Blt	Eff Yr Blt	Inventory	
Multi-Purpose Bldg	4	Finished	70	0	0	1950	1950	FAIR	Exception: Y N

**Accessories**

Description	Class	Size SqFt	Eff Yr Blt	RMV	Quantity
No accessory data available					

# SKETCH/AREA TABLE ADDENDUM

## SUBJECT INFO

File No.: 515494 & 515495 Parcel No.: 061W02 00100, 00100A1  
 Property Address: 14358 Dominic Rd NE  
 City: Mt Angel County: State: OR ZipCode: 97362  
 Owner:  
 Client: Client Address:  
 Appraiser Name: Inspection Date:

## SKETCH

515494 & 515495  
 061W 02 00100, 00100A1  
 See Additional Pages for Dimensions  
 Scale 1:140

Blue lines represent property lines

515494

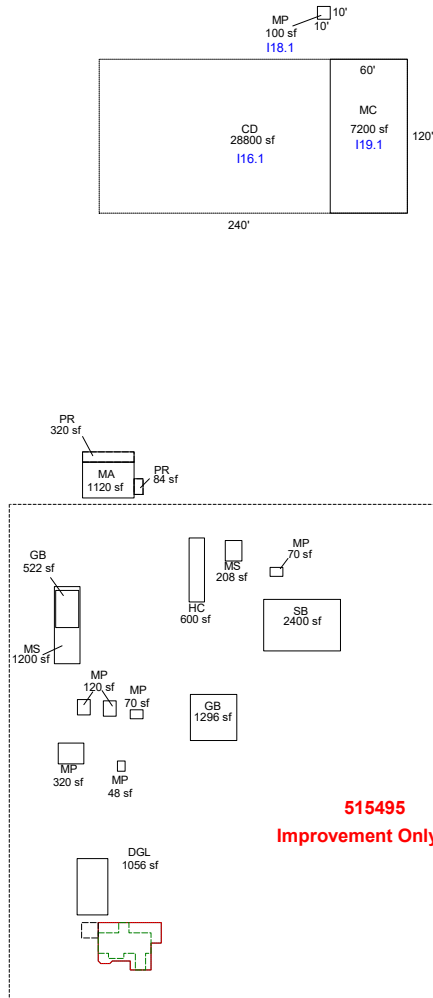

515495  
 Improvement Only Acct

Sketch by ApexSketch

### AREA CALCULATIONS SUMMARY

Code	Description	Factor	Net Size	Perimeter	Net Totals
GBA1	MP	1.0	120.0	44.0	
	MP	1.0	100.0	40.0	
	MS	1.0	1200.0	160.0	
	MP	1.0	522.0	94.0	
	GB	1.0	1296.0	144.0	
	LTE	1.0	320.0	96.0	
	LTE	1.0	84.0	38.0	
	MS	1.0	1740.0	314.0	
	MP	1.0	48.0	28.0	
	MS	1.0	160.0	56.0	
	UB	1.0	5000.0	330.0	
	LTH	1.0	272.0	84.0	
	LTH	1.0	390.0	98.0	
	MS	1.0	660.0	106.0	
MC	1.0	4410.0	266.0		
21 addl items					
	Net LIVABLE	cnt	1 (rounded)		4,536
	Net BUILDING	cnt	0 (rounded)		35,288

### COMMENT TABLE 1

Apex by RW 05/13/08  
 Updated by CW 3/13/14  
 UPDATED BY CLOBERG 02/02/26

### COMMENT TABLE 2

MLH 08/28/25

### COMMENT TABLE 3

CLEAN UP L4

# SKETCH/AREA TABLE ADDENDUM

## SUBJECT INFO

File No.: 515494 & 515495 Parcel No.: 061W02 00100, 00100A1  
 Property Address: 14358 Dominic Rd NE  
 City: Mt Angel County: State: OR ZipCode: 97362  
 Owner:  
 Client: Client Address:  
 Appraiser Name: Inspection Date:

## SKETCH

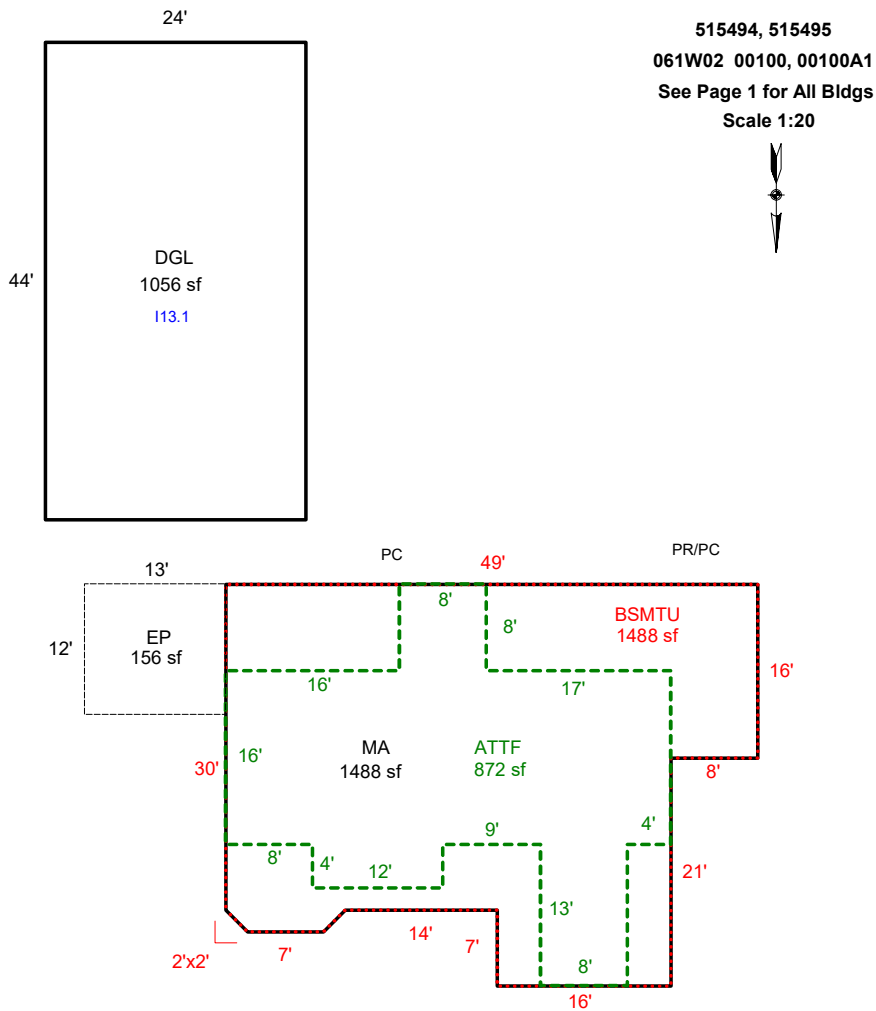

### AREA CALCULATIONS SUMMARY

Code	Description	Factor	Net Size	Perimeter	Net Totals
GLA1	MA	1.0	1488.0	173.7	1488.0
GLA2	ATTF	1.0	872.0	164.0	872.0
BSMT	BSMTU	1.0	1488.0	173.7	1488.0
GAR	DGL	1.0	1056.0	136.0	1056.0
P/P	EP	1.0	156.0	50.0	156.0

### COMMENT TABLE 1

Apex by RW 05/13/08  
 Updated by CW 3/13/14  
 UPDATED BY CLOBERG 02/02/26

### COMMENT TABLE 2

MLH 08/28/25

### COMMENT TABLE 3

CLEAN UP L4

Net LIVABLE                      cnt                      1                      (rounded)                      3,416

# SKETCH/AREA TABLE ADDENDUM

## SUBJECT INFO

File No.: 515494 & 515495 Parcel No.: 061W02 00100, 00100A1  
 Property Address: 14358 Dominic Rd NE  
 City: Mt Angel County: State: OR ZipCode: 97362  
 Owner:  
 Client: Client Address:  
 Appraiser Name: Inspection Date:

## SKETCH

515494, 515495  
 061W02 00100, 00100A1  
 See Page 1 for All Bldgs

Scale 1:60



Blue lines indicate property line

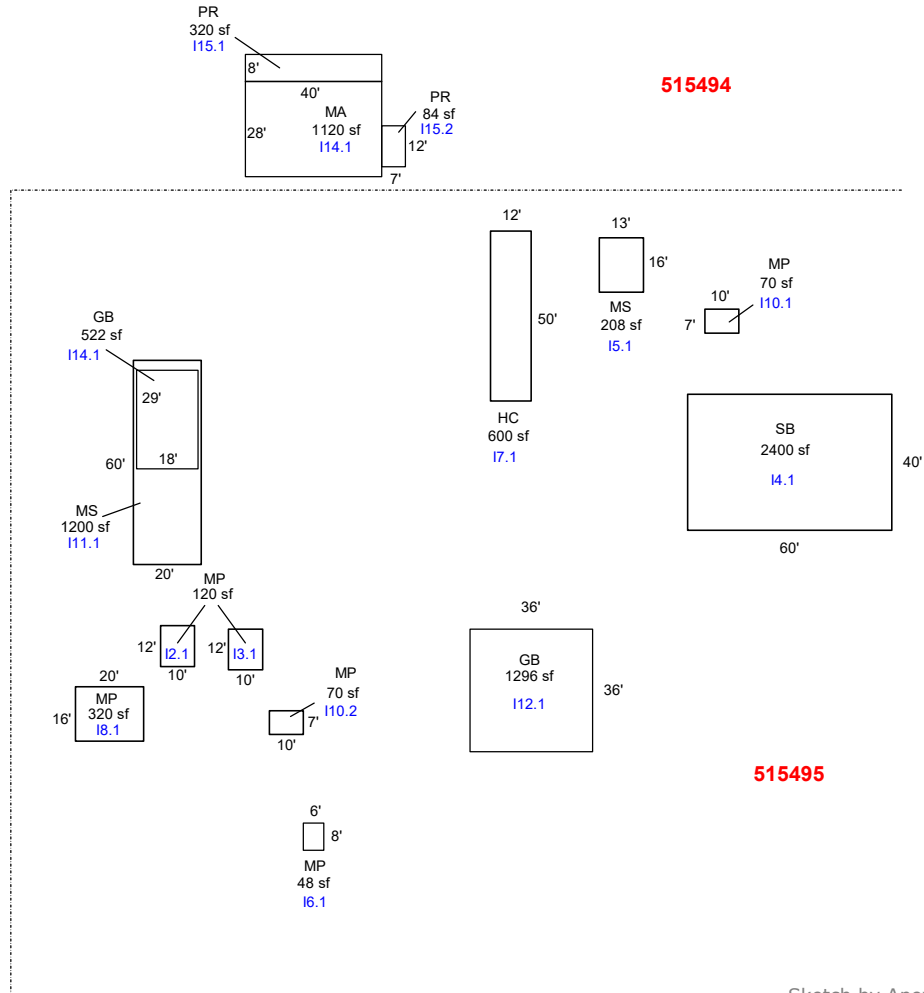

515494

515495

Sketch by ApexSketch

### AREA CALCULATIONS SUMMARY

Code	Description	Factor	Net Size	Perimeter	Net Totals
GBA1	MP	1.0	120.0	44.0	
	MP	1.0	120.0	44.0	
	SB	1.0	2400.0	200.0	
	MS	1.0	208.0	58.0	
	HC	1.0	600.0	124.0	
	MP	1.0	320.0	72.0	
	MP	1.0	70.0	34.0	
	MP	1.0	70.0	34.0	
	MS	1.0	1200.0	160.0	
	MP	1.0	48.0	28.0	
	PR	1.0	84.0	38.0	
	PR	1.0	320.0	96.0	
	MP	1.0	522.0	94.0	
	GB	1.0	1296.0	144.0	7378.0
GLA1	MA	1.0	1120.0	136.0	1120.0
	Net LIVABLE	cnt	0 (rounded)		1,120
	Net BUILDING	cnt	0 (rounded)		7,378

### COMMENT TABLE 1

Apex by RW 05/13/08  
 Updated by CW 3/13/14  
 UPDATED BY CLOBERG 02/02/26

### COMMENT TABLE 2

MLH 08/28/25

### COMMENT TABLE 3

CLEAN UP L4

# SKETCH/AREA TABLE ADDENDUM

## SUBJECT INFO

File No.: 515494 & 515495 Parcel No.: 061W02 00100, 00100A1  
 Property Address: 14358 Dominic Rd NE  
 City: Mt Angel County: State: OR ZipCode: 97362  
 Owner:  
 Client: Client Address:  
 Appraiser Name: Inspection Date:

## SKETCH

519494, 519495  
 061W02 00100, 00100A1  
 See Page 1 for All Bldgs  
 Scale 1:50

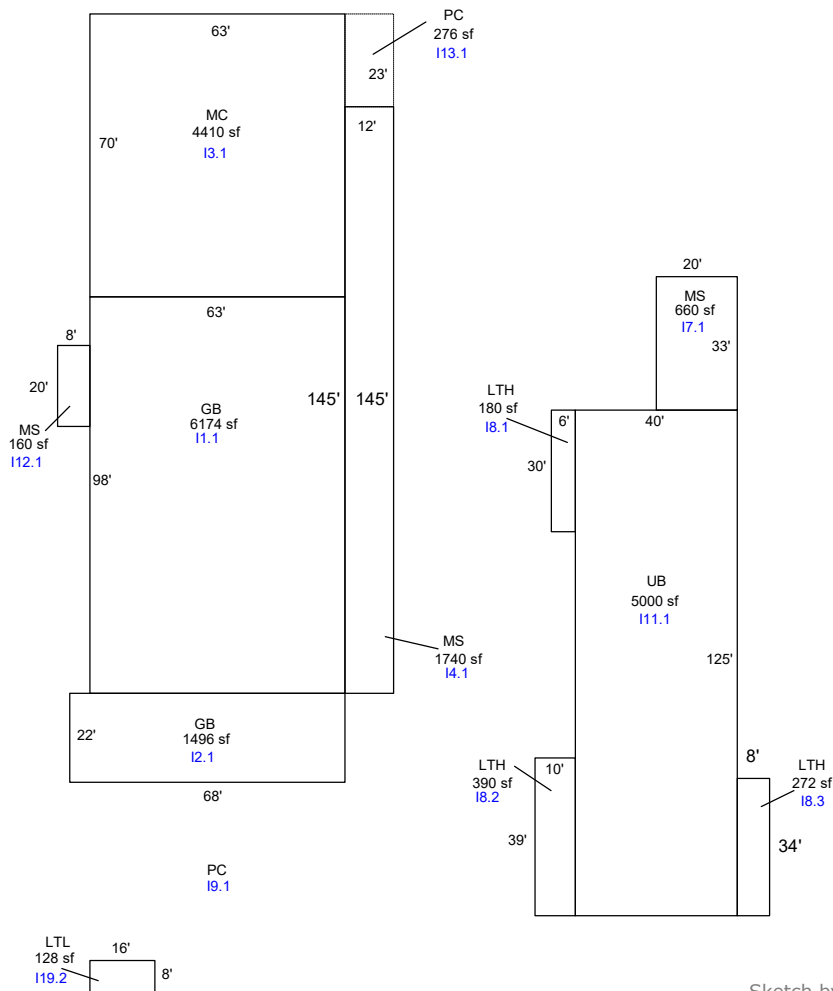

Sketch by ApexSketch

AREA CALCULATIONS SUMMARY						COMMENT TABLE 1				
Code	Description	Factor	Net Size	Perimeter	Net Totals					
GBA1	MC	1.0	4410.0	266.0		Apex by RW 05/13/08 Updated by CW 3/13/14 UPDATED BY CLOBERG 02/02/26				
	GB	1.0	6174.0	322.0						
	GB	1.0	1496.0	180.0						
	MS	1.0	1740.0	314.0						
	MS	1.0	660.0	106.0						
	UB	1.0	5000.0	330.0						
	LTH	1.0	180.0	72.0						
	LTH	1.0	390.0	98.0						
	MS	1.0	160.0	56.0						
	LTL	1.0	128.0	48.0						
	LTH	1.0	272.0	84.0	20610.0			<b>COMMENT TABLE 2</b> MLH 08/28/25		
	P/P	PC	1.0	276.0	70.0					276.0
		Net BUILDING	cnt	0 (rounded)				20,610		

# SKETCH/AREA TABLE ADDENDUM

Parcel No 061W02 00100, 00100A1

File No R15494 & R15495

SUBJECT	Property Address <b>14358 Dominic Rd NE</b>	State <b>OR</b>	Zip <b>97362</b>
	City <b>Mt Angel</b>		
	Owner		
	Client		
	Appraiser Name		

R15494 & R15495  
061W 02 00100, 00100A1  
See Additional Pages for Dimensions  
Scale 1:140

Blue lines represent property lines

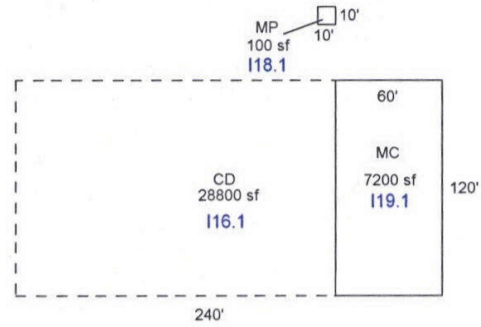

R15494

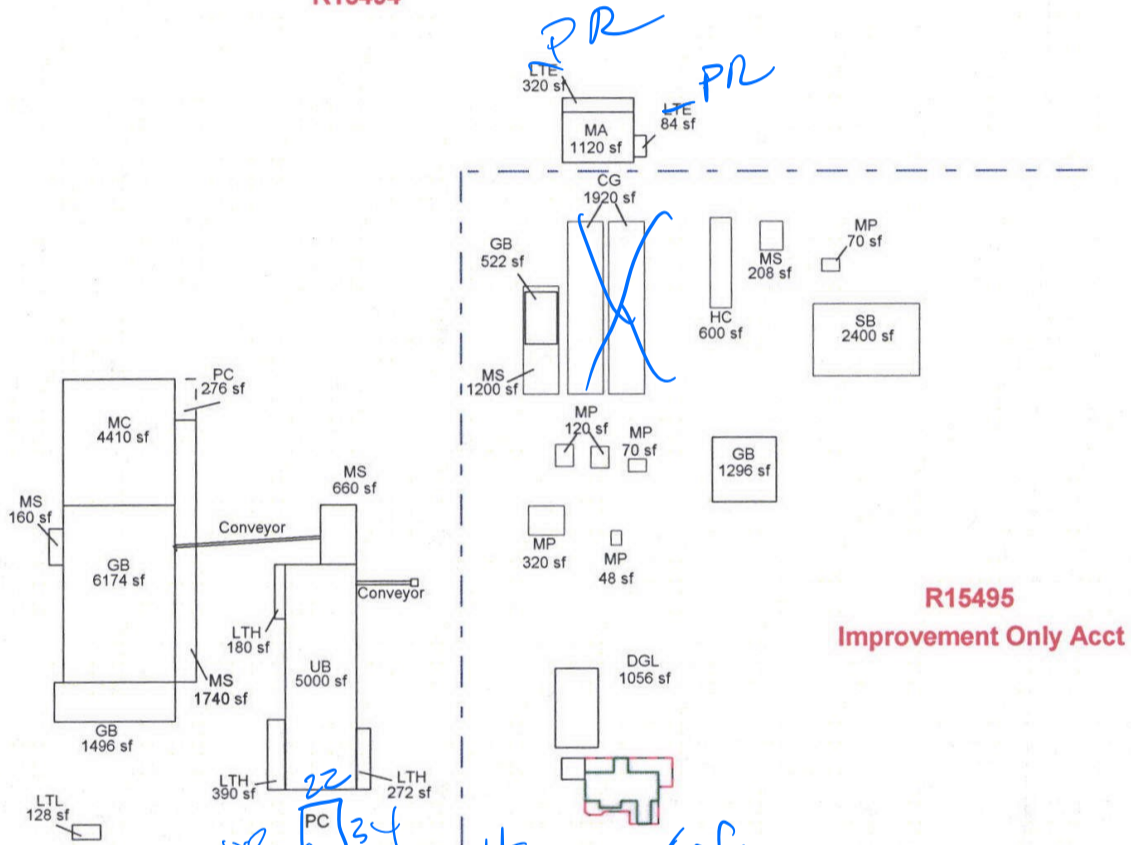

R15495  
Improvement Only Acct

Scale: 1 = 140

IMPROVEMENTS SKETCH

AREA CALCULATIONS

### AREA CALCULATIONS SUMMARY

Code	Description	Factor	Net Size	Perimeter	Net Totals
GLA1	MA	1.00	1120	136	
	MA	1.00	1488	174	2608
GLA2	ATTF	1.00	872	164	872
GBA1	MP	1.00	120	44	
	MP	1.00	120	44	
	SB	1.00	2400	200	
	MS	1.00	208	58	
	HC	1.00	600	124	
	MP	1.00	320	72	
	HH	1.00	1920	232	
	HH	1.00	1920	232	
	MP	1.00	70	34	
	MP	1.00	70	34	
	GB	1.00	6174	322	
	GB	1.00	1496	180	
	MC	1.00	4410	266	
	MS	1.00	660	106	
	LTH	1.00	180	72	
	LTH	1.00	390	98	
	LTH	1.00	272	84	
----- 17 Items Not Listed ----- Net LIVABLE Area (rounded w/ factors)					3480
Net BUILDING Area (rounded w/ factors)					39128

#### Comment Table 1

Apex by RW 05/13/08  
Updated by CW 3/13/14

#### Comment Table 2

3/20/25  
MCH

#### Comment Table 3

cleanup  
L4