

Acct ID: 562740 MTL: 081W18C001400 Date: 3.22.26 Appr: JJS Prop Class: 409 RMV Prop Class: 409  
 Situs: 5992 VILLAGE VIEW CT SE AUMSVILLE OR 97325 MaSaNh: 01 06 000 Unit: 103046 Year: 2026

Last Date Appraised: 06/21/2021 Appraiser: CLINT LUKE Tag: Y Tag info: \_\_\_\_\_  
 Owner: LUPIAN LUA, HERNAN Last Sales Date: 01/20/2026 Roll Type: R  
 Cycle Tag Sales Verification Other: \_\_\_\_\_ Inspection level: 1 2 3 4 LCB TTO INSP AV: 355450  
 RMV Land: 320700 RMV Imp: 286920 RMV Total: 607700 MAV: 355450 MSAV: 0 SAV: 0  
 Comment: LEVEL 4 6.21.21 CL10

DELETE DUP YIS, ADD HC PKG

MLS: 835655  
Dom: 58 code: 30

OSDs

Count	Code	Description	RMV	Code Area	Exception
1	MKTA	OSD - AVERAGE	55000	05558	0

Land

Site: 1 Code Area: 05558 Size: 2.58 Acres Use Code: 004 Zone: NREST SAV Use: \_\_\_\_\_ Exception: 0  
 Class: 4BDSS Value Source: Rural at MKT Description: FOUR BENCH DRY SPECIAL SOUTH RMV: 265780 Exception: Y N  
 Adjustment(s): \_\_\_\_\_ Fire Patrol: \_\_\_\_\_ Description: \_\_\_\_\_  
 Comments: 24-25 ADD SOIL 2002-03 REAPPRAISAL.

Improvements - Residence / Manufactured Structures

Bldg: 5 Code Area: 05558 Stat Class: 467 Year Blt: 2003 Eff Year Blt: 2006 Sq.Ft: 2628 % Complete: 100.00  
 Desc: MANUF STRUCT, CLASS 6, 26' THROUGH 28' WIDE DOUBLE Dimensions: \_\_\_\_\_ RMV: 202810  
 Func Obsc: 100 Econ %: 100 Other %: 100 Exception: 0 Adjust: \_\_\_\_\_ Adjust RMV: 0 Subtype: E

Floors

Type	Class	Display Group	Floor Size	Beds	Baths	Yr Blt	Eff Yr Blt	Inventory	Exception
First Floor	6	Finished	2628	3	FB-2	2003	2006	SKRT+, HVAC, FP - 1, BATH - 3, KIT-, ROOF	Y N

Accessories

Description	Class	Size SqFt	Eff Yr Blt	RMV	Quantity	Exception
DECK	6	72	2006	1267	1	Y N
PATIO	6	112	2006	493	1	Y N
PATIO	6	160	2006	704	1	Y N
PATIO	6	180	2006	792	1	Y N
ROOF EXTENSION OR PATIO COVER	6	72	2006	1670	1	Y N
ROOF EXTENSION OR PATIO COVER	6	112	2006	2598	1	Y N

Bldg: 9 Code Area: 05558 Stat Class: 107 Year Blt: \_\_\_\_\_ Eff Year Blt: 2006 Sq.Ft: 0 % Complete: 100.00  
 Desc: Yard Improvements Dimensions: \_\_\_\_\_ RMV: 32940  
 Func Obsc: 100 Econ %: 100 Other %: 100 Exception: 0 Adjust: \_\_\_\_\_ Adjust RMV: 0

Floors

Type	Class	Display Group	Floor Size	Beds	Baths	Yr Blt	Eff Yr Blt	Inventory	Exception
No floor data available									

Accessories

Description	Class	Size SqFt	Eff Yr Blt	RMV	Quantity	Exception
YARD IMPROVEMENTS GOOD	4	0	2006	32942	1	Y N

Improvements - Accessory Buildings

Bldg: 1 Code Area: 05558 Stat Class: 351 Year Blt: 2000 Eff Year Blt: 2000 Sq.Ft: 864 % Complete: 100.00  
 Desc: General Purpose Building (GB) Dimensions: \_\_\_\_\_ RMV: 10980  
 Func Obsc: 100 Econ %: 100 Other %: 100 Exception: 0 Adjust: \_\_\_\_\_ Adjust RMV: 0

Floors

Type	Class	Display Group	Floor Size	Beds	Baths	Yr Blt	Eff Yr Blt	Inventory	Exception
General Purpose Bldg	5	Finished	864	0	0	2000	2000	FAIR	Y N

Accessories

Description	Class	Size SqFt	Eff Yr Blt	RMV	Quantity	Exception
No accessory data available						

Bldg: 2 Code Area: 05558 Stat Class: 351 Year Blt: 2000 Eff Year Blt: 2000 Sq.Ft: 576 % Complete: 100.00  
 Desc: General Purpose Building (GB) Dimensions: 24x24 RMV: 7320  
 Func Obsc: 100 Econ %: 100 Other %: 100 Exception: 0 Adjust: \_\_\_\_\_ Adjust RMV: 0

Floors

Type	Class	Display Group	Floor Size	Beds	Baths	Yr Blt	Eff Yr Blt	Inventory
General Purpose Bldg	5	Finished	576	0	0	2000	2000	FAIR

Exception: Y N

**Accessories**

Description	Class	Size SqFt	Eff Yr Blt	RMV	Quantity
No accessory data available					

Bldg: 4 Code Area: 05558 Stat Class: 351 Year Blt: 2002 Eff Year Blt: 2002 Sq.Ft: 1920 % Complete: 100.00  
 Desc: General Purpose Building (GB) Dimensions: 48x40 RMV: 26940  
 Func Obsc: 100 Econ %: 100 Other %: 100 Exception: 0 Adjust: Adjust RMV: 0

**Floors**

Type	Class	Display Group	Floor Size	Beds	Baths	Yr Blt	Eff Yr Blt	Inventory
General Purpose Bldg	5	Finished	1920	0	0	2002	2002	AVG

Exception: Y N

**Accessories**

Description	Class	Size SqFt	Eff Yr Blt	RMV	Quantity
No accessory data available					

Bldg: 8 Code Area: 05558 Stat Class: 321 Year Blt: 2012 Eff Year Blt: 2012 Sq.Ft: 960 % Complete: 100.00  
 Desc: Hay Cover (HC) Dimensions: RMV: 5930  
 Func Obsc: 100 Econ %: 100 Other %: 100 Exception: 0 Adjust: Adjust RMV: 0

**Floors**

Type	Class	Display Group	Floor Size	Beds	Baths	Yr Blt	Eff Yr Blt	Inventory
Hay Cover	5	Finished	960	0	0	2012	2012	F

Exception: Y N

**Accessories**

Description	Class	Size SqFt	Eff Yr Blt	RMV	Quantity
No accessory data available					

# SKETCH/AREA TABLE ADDENDUM

## SUBJECT INFO

File No.: 562740 Parcel No.: 081W18C01400  
 Property Address: 5992 VILLAGE VIEW CT SE  
 City: AUMSVILLE County: State: OR ZipCode: 97325  
 Owner:  
 Client: Client Address:  
 Appraiser Name: Inspection Date:

## SKETCH

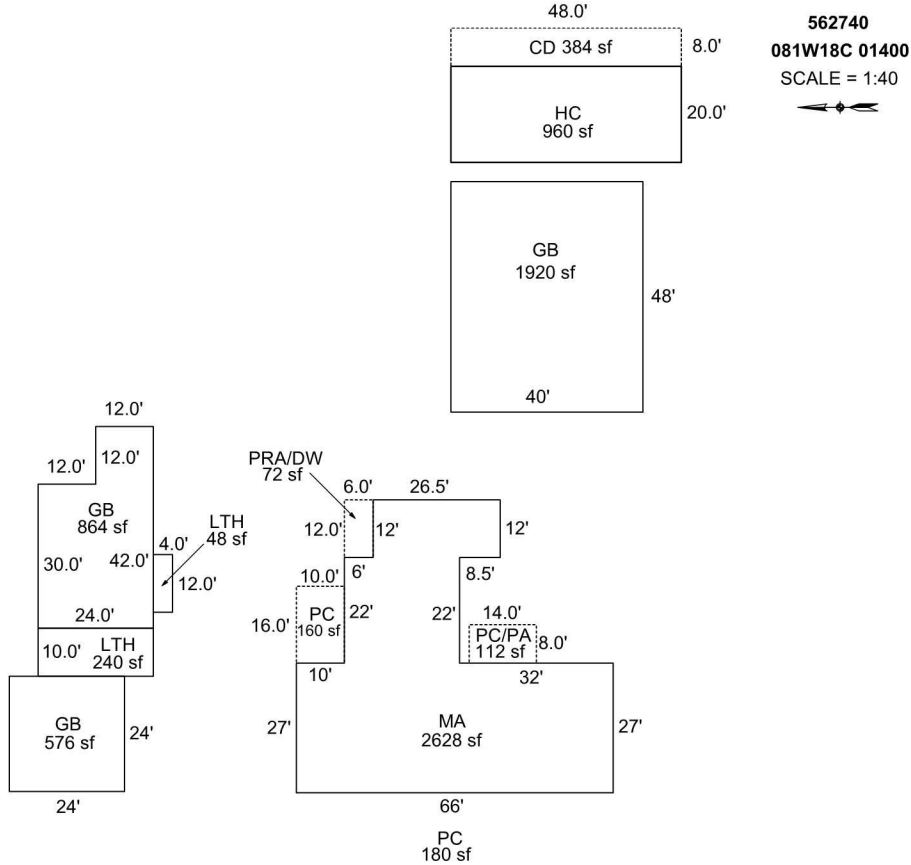

Sketch by Apex Sketch

### AREA CALCULATIONS SUMMARY

Code	Description	Factor	Net Size	Perimeter	Net Totals
GBA1	GB	1.0	1920.0	176.0	
	GB	1.0	576.0	96.0	
	LTH	1.0	240.0	68.0	
	GB	1.0	864.0	132.0	
	HC	1.0	960.0	136.0	
	LTH	1.0	48.0	32.0	4608.0
	MA	1.0	2628.0	271.0	2628.0
GLA1 P/P	PC/PA	1.0	112.0	44.0	
	PRA/DW	1.0	72.0	36.0	
	PC	1.0	160.0	52.0	
	CD	1.0	384.0	112.0	728.0
	Net LIVABLE	cnt	1 (rounded)		2,628
Net BUILDING	cnt	6 (rounded)		4,608	

### COMMENT TABLE 1

APEX BY CE 10/7/09  
 UPDATED BY CJURAN 02/15/2022

### COMMENT TABLE 2

#10 CL 06/21/2021

JSS  
3.19.26

### COMMENT TABLE 3

SV L4

SV L4





