

Acct ID: 564515 MTL: 092W13AD00100 Date: 2/26/26 Appr: MW Prop Class: 551 RMV Prop Class: 451  
 Situs: 9478 SNODDY DR SE AUMSVILLE OR 97325 MaSaNh: 07 06 000 Unit: 104390 Year: 2026

Last Date Appraised: 08/05/2021 Appraiser: MATT LORD Tag: Y N Tag info:

Owner: BERMAN, MELISSA A Last Sales Date: 09/22/2025 Roll Type: R  
 Cycle Tag Sales Verification Other: \_\_\_\_\_ Inspection level: 1 2 3 4 LCB TTO INSP AV: 102429  
 RMV Land: 396940 RMV Imp: 142760 RMV Total: 539700 MAV: 83490 MSAV: 18939 SAV: 76699  
 Comment: LEVEL 2 8.5.21 CL10

*group yr, chg GB to LB*

*MCS 827484  
Dom 144  
CSOM 329*

**Notations**

RP/MS	Code	Description
RP	ZONED	FARM EFU ZONED

**OSDs**

Count	Code	Description	RMV	Code Area	Exception
1	SAF	SA OSD - FAIR	45000	05545	0

**Land**

Site: 2 Code Area: 05545 Size: 1.00 Acres Use Code: 005 Zone: REST SAV Use: 011 Exception: 0  
 Class: Value Source: Farm Homesite Description: 4BDSS RMV: 50310 Exception: Y N  
 Adjustment(s): IRR Fire Patrol: Description:  
 Comments: Liability year - 2009 / 550040

Site: 3 Code Area: 05545 Size: 5.71 Acres Use Code: 005 Zone: REST SAV Use: 011 Exception: 0  
 Class: 4BISS Value Source: Farm Use - EFU Description: FOUR BENCH IRR SPECIAL SOUTH RMV: 301630 Exception: Y N  
 Adjustment(s): IRR 4BDSS Fire Patrol: Description:  
 Comments: Liability year - 1980 / 550040

**Improvements - Residence / Manufactured Structures**

Bldg: 1 Code Area: 05545 Stat Class: 132 Year Blt: 1910 Eff Year Blt: 1947 Sq.Ft: 1315 % Complete: 100.00  
 Desc: Multi Story above grade Dimensions: RMV: 108050  
 Func Obsc: 100 Econ %: 100 Other %: 100 Exception: 0 Adjust: Adjust RMV: 0

**Floors**

Type	Class	Display Group	Floor Size	Beds	Baths	Yr Blt	Eff Yr Blt	Inventory	Exception
First Floor	3	Finished	987	2	FB-1	1910	1947	HVAC, ROOF, KIT-, BATH - 1 PP	Y N
Attic	3	Low Cost	328	1	1	1910	1947	HVAC Bath	Y N

**Accessories**

Description	Class	Size SqFt	Eff Yr Blt	RMV	Quantity	Exception
DECK	3	192	1947	2746	1	Y N
DECK	3	400	1947	5720	1	Y N
ROOF EXTENSION OR PATIO COVER	3	192	1947	3619	1	Y N

**Improvements - Accessory Buildings**

Bldg: 2 Code Area: 05545 Stat Class: 354 Year Blt: 1910 Eff Year Blt: 1910 Sq.Ft: 296 % Complete: 100.00  
 Desc: Lean-to Light (LTL) Dimensions: RMV: 260  
 Func Obsc: 100 Econ %: 100 Other %: 100 Exception: 0 Adjust: Adjust RMV: 0

**Floors**

Type	Class	Display Group	Floor Size	Beds	Baths	Yr Blt	Eff Yr Blt	Inventory	Exception
Lean-to Light Duty	4	Finished	296	0	0	1910	1910	CONVERSION ERIDE NIV	Y N

**Accessories**

No accessory data available

Bldg: 3 Code Area: 05545 Stat Class: 341 Year Blt: 1995 Eff Year Blt: 1995 Sq.Ft: 192 % Complete: 100.00  
 Desc: Multi Purpose Shed (MP) Dimensions: 16x12 RMV: 2000  
 Func Obsc: 100 Econ %: 100 Other %: 100 Exception: 0 Adjust: Adjust RMV: 0

**Floors**

Type	Class	Display Group	Floor Size	Beds	Baths	Yr Blt	Eff Yr Blt	Inventory	Exception
Multi-Purpose Bldg	4	Finished	192	0	0	1995	1995	FAIR	Y N

**Accessories**

Description	Class	Size SqFt	Eff Yr Blt	RMV	Quantity
No accessory data available					

Bldg: 4 Code Area: 05545 Stat Class: 351 Year Blt: 1980 Eff Year Blt: 1980 Sq.Ft: 768 % Complete: 100.00  
 Desc: General Purpose Building (GB) Dimensions: 32x24 RMV: 3900  
 Func Obsc: 100 Econ %: 100 Other %: 100 Exception: 0 Adjust: Adjust RMV: 0

**Floors**

Type	Class	Display Group	Floor Size	Beds	Baths	Yr Blt	Eff Yr Blt	Inventory	Exception: Y N
General Purpose Bldg	5	Finished	768	0	0	1980	1980	FAIR	Exception: Y N

**Accessories**

Description	Class	Size SqFt	Eff Yr Blt	RMV	Quantity
No accessory data available					

Bldg: 5 Code Area: 05545 Stat Class: 351 Year Blt: 2007 Eff Year Blt: 2007 Sq.Ft: 1596 % Complete: 100.00  
 Desc: General Purpose Building (GB) *Wjt Barn* Dimensions: 38x42 RMV: 28550  
 Func Obsc: 100 Econ %: 100 Other %: 100 Exception: 0 Adjust: Adjust RMV: 0

**Floors**

Type	Class	Display Group	Floor Size	Beds	Baths	Yr Blt	Eff Yr Blt	Inventory	Exception: Y N
General Purpose Bldg	6	Finished	1596	0	0	2007	2007	FAIR	Exception: Y <u>N</u>

**Accessories**

Description	Class	Size SqFt	Eff Yr Blt	RMV	Quantity
No accessory data available					

# SKETCH/AREA TABLE ADDENDUM

## SUBJECT INFO

File No.: 564515 Parcel No.: 092W13AD00100  
 Property Address: 9478 SNODDY DR SE  
 City: AUMSVILLE County: MARION State: OR ZipCode: 97325  
 Owner:  
 Client: Client Address:  
 Appraiser Name: Inspection Date:

## SKETCH

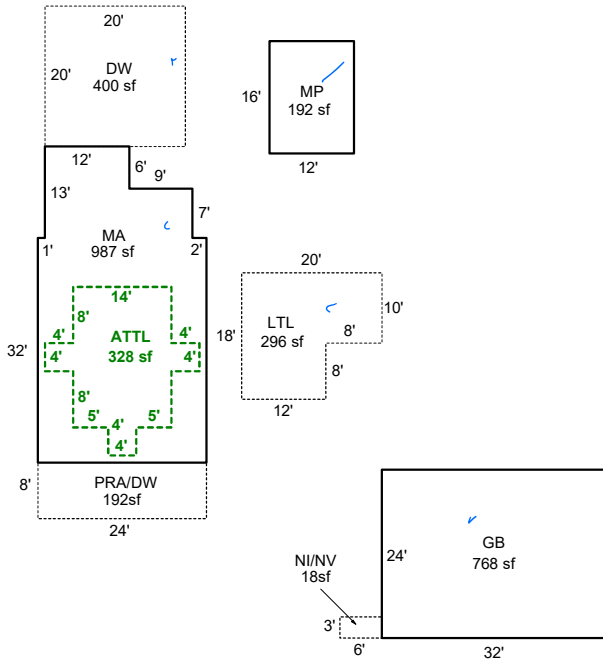
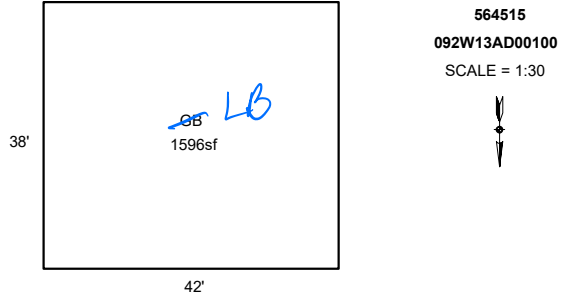

Sketch by ApexSketch

### AREA CALCULATIONS SUMMARY

Code	Description	Factor	Net Size	Perimeter	Net Totals
GBA1	LTL	1.0	296.0	76.0	
	MP	1.0	192.0	56.0	
	GB	1.0	1596.0	160.0	2852.0
	GB	1.0	768.0	112.0	
GLA1	MA	1.0	987.0	138.0	987.0
GLA2	ATTL	1.0	328.0	92.0	328.0
P/P	DW	1.0	400.0	80.0	
	NI/NV	1.0	18.0	18.0	
	PRA/DW	1.0	192.0	64.0	610.0
	Net LIVABLE	cnt	0 (rounded)		1,315
	Net BUILDING	cnt	0 (rounded)		2,852

### COMMENT TABLE 1

DRAWN BY JRONDEMA 5/24/18  
 UPDATED BY CJURAN 12/30/2021

### COMMENT TABLE 2

#49 04/19/2008  
 #10 CL 08/05/2021

### COMMENT TABLE 3

---  
 CYCLE L2

## Value Comparison MARION County

**Account ID** 564515      **Map** 092W13AD00100      **RMV Class** 451      **Property Class** 551      **Situs** 9478 SNODDY DR SE AUMSVILLE OR 97325  
**Workflow ID** 7608819      **Last** williams      **Status** Open      **Operation** Sales Verification  
**Year** 2026      **Changed** 07-Apr-2026      **Comments** GROUP YI, CHG GB TO LB

	Value Source	RMV	M5	Exception	MAV	MSAV	Taxable
Prev	Farm Homesite 1 Acres	\$50,310	\$52,450	\$0	\$0	\$8,290	\$8,290
New	Farm Homesite 1 Acres	\$50,310	\$50,310	\$0	\$0	\$8,290	\$8,290
		\$0	(\$2,140)	\$0	\$0	\$0	\$0
Prev	Farm Use - EFU 5.71 Acres	\$301,630	\$20,249	\$0	\$0	\$6,649	\$6,649
New	Farm Use - EFU 5.71 Acres	\$287,270	\$11,043	\$0	\$0	\$5,240	\$5,240
		(\$14,360)	(\$9,206)	\$0	\$0	(\$1,409)	(\$1,409)
Prev	SA OSD - FAIR	\$45,000	\$4,000	\$0	\$0	\$4,000	\$4,000
New	SA OSD - FAIR	\$45,000	\$4,000	\$0	\$0	\$4,000	\$4,000
		\$0	\$0	\$0	\$0	\$0	\$0
Prev	132 RESIDENCE 1315 Sqft	\$108,050	\$108,050	\$0	\$60,790	\$0	\$60,790
New	132 RESIDENCE 1315 Sqft	\$110,420	\$110,420	\$0	\$56,680	\$0	\$56,680
		\$2,370	\$2,370	\$0	(\$4,110)	\$0	(\$4,110)
Prev	354 FARM BLDG 296 Sqft	\$260	\$260	\$0	\$160	\$0	\$160
New	354 FARM BLDG 296 Sqft	\$0	\$0	\$0	\$0	\$0	\$0
		(\$260)	(\$260)	\$0	(\$160)	\$0	(\$160)
Prev	341 FARM BLDG 192 Sqft	\$2,000	\$2,000	\$0	\$1,860	\$0	\$1,860
New	341 FARM BLDG 192 Sqft	\$2,000	\$2,000	\$0	\$1,060	\$0	\$1,060
		\$0	\$0	\$0	(\$800)	\$0	(\$800)
Prev	351 FARM BLDG 768 Sqft	\$3,900	\$3,900	\$0	\$2,180	\$0	\$2,180
New	351 FARM BLDG 768 Sqft	\$3,900	\$3,900	\$0	\$2,070	\$0	\$2,070
		\$0	\$0	\$0	(\$110)	\$0	(\$110)
Prev	351 FARM BLDG 1596 Sqft	\$28,550	\$28,550	\$0	\$18,500	\$0	\$18,500
New	312 FARM BLDG 1596 Sqft	\$44,530	\$44,530	\$0	\$23,680	\$0	\$23,680
		\$15,980	\$15,980	\$0	\$5,180	\$0	\$5,180
	<b>Total Prev</b>	<b>\$539,700</b>	<b>\$219,459</b>	<b>\$0</b>	<b>\$83,490</b>	<b>\$18,939</b>	<b>\$102,429</b>
	<b>Total New</b>	<b>\$543,430</b>	<b>\$226,203</b>	<b>\$0</b>	<b>\$83,490</b>	<b>\$17,530</b>	<b>\$101,020</b>
	<b>Total Change</b>	<b>\$3,730</b>	<b>\$6,744</b>	<b>\$0</b>	<b>\$0</b>	<b>(\$1,409)</b>	<b>(\$1,409)</b>