

# SKETCH/AREA TABLE ADDENDUM

Parcel No **091W03DC03000**

File No **R323127**

SUBJECT	Property Address <b>310-323 WILDFLOWER DR</b>			
	City <b>STAYTON</b>	County <b>MARION</b>	State <b>OR</b>	Zip <b>97383</b>
	Owner			
	Client			
	Appraiser Name <b>MARION COUNTY COMMERCIAL</b>			

(6) EA 2ED/2BA DUPLEXES ON TAX LOT 1124 SF EACH SIDE

**R323127**  
**091W03DC03000**  
SCALE: 1" = 20'

DRAWING FOR ASSESSMENT PURPOSES ONLY

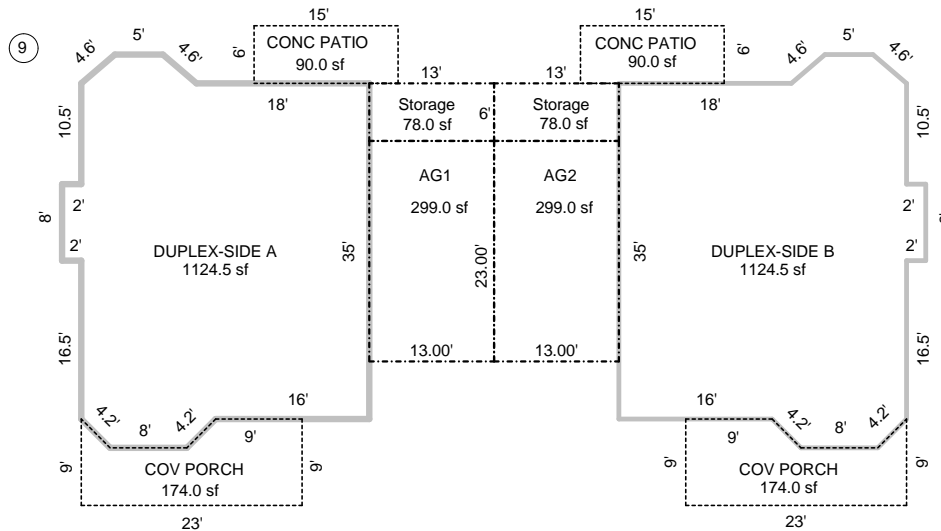

Scale: **1" = 20'**

AREA CALCULATIONS	AREA CALCULATIONS SUMMARY					
	Code	Description	Factor	Net Size	Perimeter	Net Totals
	GBA1	DUPLEX-SIDE A	1.00	1124.50	138.7	
		DUPLEX-SIDE B	1.00	1124.50	138.7	
		AG2	1.00	299.00	72.0	2548.00
	GAR	AG1	1.00	299.00	72.0	299.00
	P/P	CONC PATIO	1.00	90.00	42.0	
		CONC PATIO	1.00	90.00	42.0	
		COV PORCH	1.00	174.00	66.5	
		COV PORCH	1.00	174.00	66.5	528.00
OTH	Storage	1.00	78.00	38.0		
	Storage	1.00	78.00	38.0	156.00	
Net BUILDING Area (rounded w/ factors)					<b>2548</b>	

APEX REVISED BY JH 10-17-11 CREATE JPEG  
REV BY DHS 10.28.19 PER #4

# SKETCH/AREA TABLE ADDENDUM

Parcel No **091W03DC03000**

File No **R323127**

SUBJECT

Property Address	<b>310-323 WILDFLOWER DR</b>		
City	County	State	Zip
<b>STAYTON</b>	<b>MARION</b>	<b>OR</b>	<b>97383</b>
Owner			
Client			
Appraiser Name	<b>MARION COUNTY COMMERCIAL</b>		

IMPROVEMENTS SKETCH

**R323127**  
**091W03DC03000**  
 DRAWING FOR ASSESSMENT PURPOSES ONLY  
 SCALE: 1" = 20'

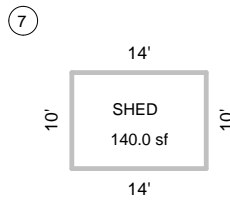

Scale: **1" = 20'**

AREA CALCULATIONS

### AREA CALCULATIONS SUMMARY

Code	Description	Factor	Net Size	Perimeter	Net Totals
GBA1	SHED	1.00	140.00	48.0	140.00
Net BUILDING Area (rounded w/ factors)					140

APEX REVISED BY JH 10-17-11 CREATE JPEG  
REV BY DHS 10.28.19 PER #4